

Model 2510 & 2510 Econominder

Service Manual

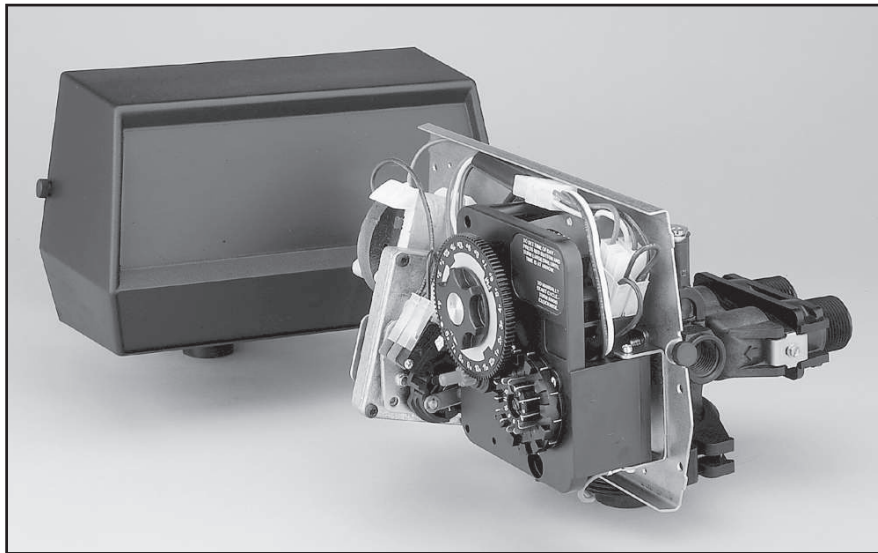

IMPORTANT: Fill in Pertinent Information on Page 3 for Future Reference

Distributed By:

**APPLIED
MEMBRANES INC.®**

2325 Cousteau Ct. Vista, CA 92081 ☎ (760) 727-3711 📠 (760) 727-4427
🌐 www.appliedmembranes.com ✉ sales@appliedmembranes.com

Table of Contents

Job Specification Sheet.....	3
Installation Instructions.....	4
Start-Up Instructions.....	5
3200 Timer Setting Procedure.....	6
3210 Timer Settings.....	7
3200 & 3210 Timer Series.....	8
3200 Timer Assembly.....	10
3210 Timer Assembly.....	12
Powerhead Assembly.....	14
Powerhead Assembly (Environmental).....	16
Manual Powerhead Assembly.....	18
Control Valve Assembly.....	20
Softener & Filter Conversion Kits.....	22
Meter Assembly.....	23
1600 Brine System Assembly.....	24
1650 Brine System Assembly.....	25
Bypass Valve Assembly (Plastic).....	26
Bypass Valve Assembly (Metal).....	27
2300 Safety Brine Valve.....	28
2310 Safety Brine Valve.....	29
Service Instructions.....	30
Seal & Spacer Replacement.....	31
Troubleshooting.....	33
Flow Data & Injector Draw Rates.....	35
Wiring Diagram.....	36
Service Assemblies.....	37



IMPORTANT PLEASE READ:

- The information, specifications and illustrations in this manual are based on the latest information available at the time of printing. The manufacturer reserves the right to make changes at any time without notice.
- This manual is intended as a guide for service of the valve only. System installation requires information from a number of suppliers not known at the time of manufacture. This product should be installed by a plumbing professional.
- This unit is designed to be installed on potable water systems only.
- This product must be installed in compliance with all state and municipal plumbing and electrical codes. Permits may be required at the time of installation.
- If daytime operating pressure exceeds 80 psi (5.5 bar), nighttime pressures may exceed pressure limits. A pressure reducing valve must be installed.
- Do not install the unit where temperatures may drop below 32°F (0°C) or above 110°F (43°C).
- Do not place the unit in direct sunlight. Black units will absorb radiant heat increasing internal temperatures.
- Do not strike the valve or any of the components.
- Warranty of this product extends to manufacturing defects. Misapplication of this product may result in failure to properly condition water, or damage to product.
- A prefilter should be used on installations in which free solids are present.
- In some applications local municipalities treat water with Chloramines. High Chloramine levels may damage valve components.
- Correct and constant voltage must be supplied to the control valve to maintain proper function.

Job Specification Sheet

Job Number: _____

Model Number: _____

Water Hardness: _____ ppm or gpg

Capacity Per Unit: _____

Mineral Tank Size: _____ Diameter: _____ Height: _____

Salt Setting per Regeneration: _____

1. Type of Timer:

- A. 7 Day or 12 Day B. Meter Initiated

2. Downflow: Upflow Upflow Variable

3. Meter Size:

- A. 3/4" Std Range (125 - 2,100 gallon setting)
B. 3/4" Ext Range (625 - 10,625 gallon setting)
C. 1" Std Range (310 - 5,270 gallon setting)
D. 1" Ext Range (1,150 - 26,350 gallon setting)
E. 1-1/2" Std Range (625 - 10,625 gallon setting)
F. 1-1/2" Ext Range (3,125 - 53,125 gallon setting)
G. 2" Std Range (1,250 - 21,250 gallon setting)
H. 2" Ext Range (6,250 - 106,250 gallon setting)
I. 3" Std Range (3,750 - 63,750 gallon setting)
J. 3" Ext Range (18,750 - 318,750 gallon setting)
K. Electronic _____ Pulse Count _____ Meter Size

4. System Type:

- A. System #4: 1 Tank, 1 Meter, Immediate, or Delayed Regeneration
B. System #4: Time Clock
C. System #4: Twin Tank
D. System #5: 2-5 Tanks, 2 Meters, Interlock
E. System #6: 2-5 Tanks, 1 Meter, Series Regeneration
F. System #7: 2-5 Tanks, 1 Meter, Alternating
G. System #9: Electronic Only, 2-4 Tanks, Meter per Valve, Alternating
H. System #14: Electronic Only, 2-4 Tanks, Meter per Valve. Brings units on and offline based on flow.

5. Timer Program Settings:

- A. Backwash: _____ Minutes
B. Brine and Slow Rinse: _____ Minutes
C. Rapid Rinse: _____ Minutes
D. Brine Tank Refill: _____ Minutes
E. Pause Time: _____ Minutes
F. Second Backwash: _____ Minutes

6. Drain Line Flow Control: _____ gpm

7. Brine Line Flow Controller: _____ gpm

8. Injector Size#: _____

9. Piston Type:

- A. Hard Water Bypass
B. No Hard Water Bypass

Installation Instructions

WATER PRESSURE: A minimum of 20 pounds of water pressure (1.3 bar) is required for regeneration valve to operate effectively.

ELECTRICAL FACILITIES: An uninterrupted alternating current (A/C) supply is required. Note: Other voltages are available. Please make sure your voltage supply is compatible with your unit before installation.

EXISTING PLUMBING: Condition of existing plumbing should be free from lime and iron buildup. Piping that is built up heavily with lime and/or iron should be replaced. If piping is clogged with iron, a separate iron filter unit should be installed ahead of the water softener.

LOCATION OF SOFTENER AND DRAIN: The softener should be located close to a drain to prevent air breaks and back flow.

BY-PASS VALVES: Always provide for the installation of a by-pass valve if unit is not equipped with one.

CAUTION: Water pressure is not to exceed 125 psi (8.6 bar), water temperature is not to exceed 110°F (43°C), and the unit cannot be subjected to freezing conditions.

Installation Instructions

1. Place the softener tank where you want to install the unit making sure the unit is level and on a firm base.
2. During cold weather, the installer should warm the valve to room temperature before operating.
3. All plumbing should be done in accordance with local plumbing codes. The pipe size for residential drain line should be a minimum of 1/2" (13 mm). Backwash flow rates in excess of 7 gpm (26 Lpm) or length in excess of 20' (6 m) require 3/4" (19 mm) drain line. Commercial drain lines should be the same size as the drain line flow control.
4. Refer to the dimensional drawing for cutting height of the distributor tube. If there is no dimensional drawing, cut the distributor tube flush with the top of the tank.
5. Lubricate the distributor O-ring seal and tank O-ring seal. Place the main control valve on tank. Note: Only use silicone lubricant.
6. Solder joints near the drain must be done prior to connecting the Drain Line Flow Control fitting (DLFC). Leave at least 6" (15 cm) between the DLFC and solder joints when soldering pipes that are connected on the DLFC. Failure to do this could cause interior damage to the DLFC.
7. Teflon tape is the only sealant to be used on the drain fitting. The drain from twin tank units may be run through a common line.
8. Make sure that the floor is clean beneath the salt storage tank and that it is level.
9. Place approximately 1" (25 mm) of water above the grid plate. If a grid is not utilized, fill to the top of the air check (Figure 1) in the salt tank. Do not add salt to the brine tank at this time.
10. On units with a by-pass, place in by-pass position. Turn on the main water supply. Open a cold soft water tap nearby and let run a few minutes or until the system is free from foreign material (usually solder) that may have resulted from the installation. Once clean, close the water tap.
11. Slowly place the by-pass in service position and let water flow into the mineral tank. When water flow stops, slowly open a cold water tap nearby and let run until the air is purged from the unit.
12. Plug unit into an electrical outlet. Note: All electrical connections must be connected according to local codes. Be certain the outlet is uninterrupted.

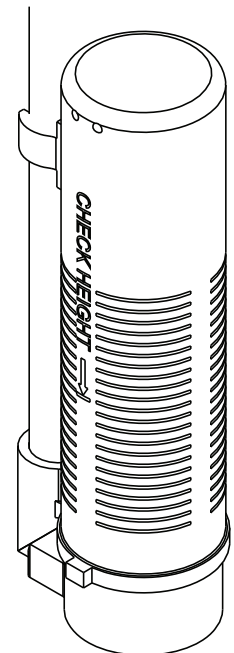

60002-34REVC

Figure 1 Residential Air Check Valve

	<p>CAUTION</p> <ul style="list-style-type: none">• Do not exceed 125 psi water pressure• Do not exceed 110°F (43°C) water temperature• Do not subject unit to freezing conditions
--	--

Start-Up Instructions

The water softener should be installed with the inlet, outlet, and drain connections made in accordance with the manufacturer's recommendations, and to meet applicable plumbing codes.

1. Turn the manual regeneration knob slowly in a clockwise direction until the program micro switch lifts on top of the first set of pins. Allow the drive motor to move the piston to the first regeneration step and stop. Each time the program switch position changes, the valve will advance to the next regeneration step. Always allow the motor to stop before moving to the next set of pins or spaces.

NOTE: For electronic valves, please refer to the manual regeneration part of the timer operation section. If the valve came with a separate electronic timer service manual, refer to the timer operation section of the electronic timer service manual.

2. Position the valve to backwash. Ensure the drain line flow remains steady for 10 minutes or until the water runs clear (see above).
3. Position the valve to the brine / slow rinse position. Ensure the unit is drawing water from the brine tank (this step may need to be repeated).
4. Position the valve to the rapid rinse position. Check the drain line flow, and run for 5 minutes or until the water runs clear.
5. Position the valve to the start of the brine tank fill cycle. Ensure water goes into the brine tank at the desired rate. The brine valve drive cam will hold the valve in this position to fill the brine tank for the first regeneration.
6. Replace control box cover.
7. Put salt in the brine tank.

NOTE: Do not use granulated or rock salt.

3200 Timer Setting Procedure

How To Set Days On Which Water Conditioner Is To Regenerate (Figure 2):

Rotate the skipper wheel until the number "1" is at the red pointer. Set the days that regeneration is to occur by sliding tabs on the skipper wheel outward to expose trip fingers. Each tab is one day. Finger at red pointer is tonight. Moving clockwise from the red pointer, extend or retract fingers to obtain the desired regeneration schedule.

How To Set The Time Of Day:

1. Press and hold the red button in to disengage the drive gear.
2. Turn the large gear until the actual time of day is at the time of day pointer.
3. Release the red button to again engage the drive gear.

How To Manually Regenerate Your Water Conditioner At Any Time:

1. Turn the manual regeneration knob clockwise.
2. This slight movement of the manual regeneration knob engages the program wheel and starts the regeneration program.
3. The black center knob will make one revolution in the following approximately three hours and stop in the position shown in the drawing.
4. Even though it takes three hours for this center knob to complete one revolution, the regeneration cycle of your unit might be set only one half of this time.
5. In any event, conditioned water may be drawn after rinse water stops flowing from the water conditioner drain line.

How to Adjust Regeneration Time:

1. Disconnect the power source.
2. Locate the three screws behind the manual regeneration knob by pushing the red button in and rotating the 24 hour dial until each screw appears in the cut out portion of the manual regeneration knob.
3. Loosen each screw slightly to release the pressure on the time plate from the 24 hour gear.
4. Locate the regeneration time pointer on the inside of the 24 hour dial in the cut out.
5. Turn the time plate so the desired regeneration time aligns next to the raised arrow.
6. Push the red button in and rotate the 24 hour dial. Tighten each of the three screws.
7. Push the red button and locate the pointer one more time to ensure the desired regeneration time is correct.
8. Reset the time of day and restore power to the unit.

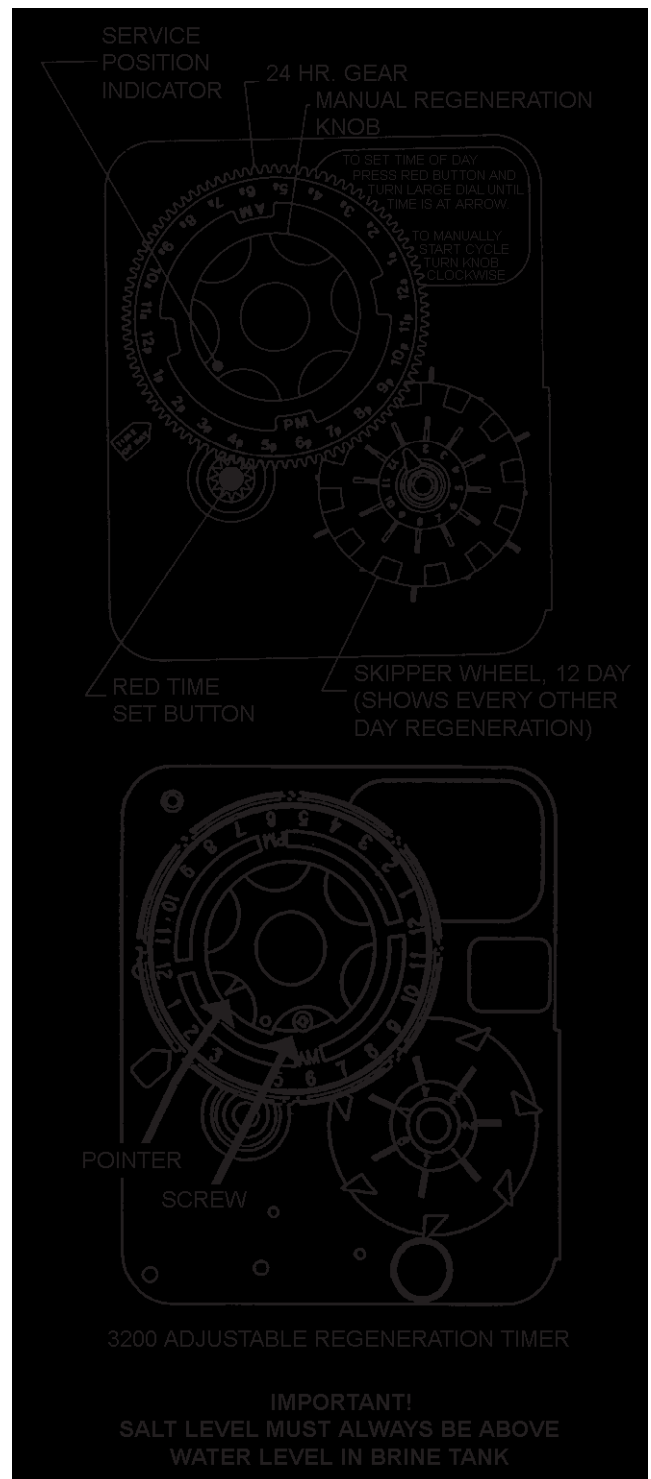

Figure 2

61502_3200REVA

Typical Programming Procedure

Calculate the gallon capacity of the system, subtract the necessary reserve requirement and set the gallons available opposite the small white dot on the program wheel gear.

NOTE: Drawing shows 8,750 gallon setting. The capacity (gallons) arrow (15) shows zero gallons remaining. The unit will regenerate tonight at the set regeneration time.

How To Set The Time Of Day:

1. Press and hold the red button in to disengage the drive gear.
2. Turn the large gear until the actual time of day is opposite the time of day pointer.
3. Release the red button to again engage the drive gear.

How To Manually Regenerate Your Water Conditioner At Any Time:

1. Turn the manual regeneration knob clockwise.
2. This slight movement of the manual regeneration knob engages the program wheel and starts the regeneration program.

The black center knob will make one revolution in the following approximately three hours and stop in the position shown in the drawing.

3. Even though it takes three hours for this center knob to complete one revolution, the regeneration cycle of your unit might be set for only one half of this time.
4. In any event, conditioned water may be drawn after rinse water stops flowing from the water conditioner drain line.

Immediate Regeneration Timers:

These timers do not have a 24 hour gear. Setting the gallons on the program wheel and manual regeneration procedure are the same as previous instructions. The timer will regenerate as soon as the capacity gallons reaches zero.

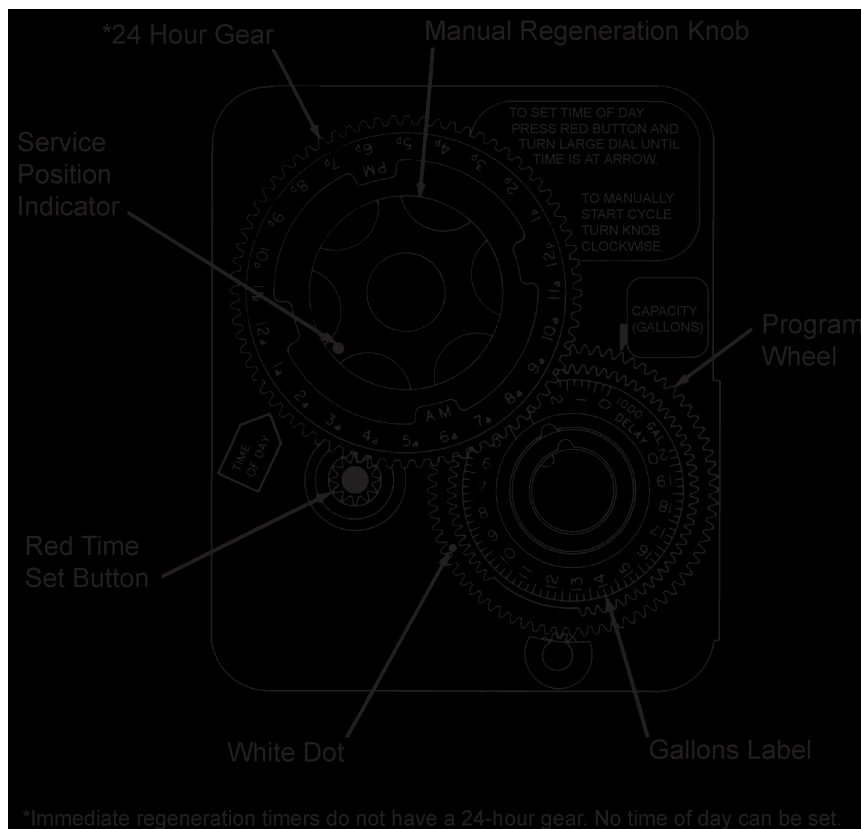

NOTE:

The program wheel to the left may be different than the program wheel on the product.

NOTE:

To set meter capacity rotate manual knob one - 360° revolution to set gallonage.

Figure 3

61502_3200REVA

3200 & 3210 Timer Series

Regeneration Cycle Program Setting Procedure (Downflow)

How To Set The Regeneration Cycle Program:

The regeneration cycle program on your water conditioner has been factory preset, however, portions of the cycle or program may be lengthened or shortened in time to suit local conditions.

3200 & 3210 Series Timers (Figure 4)

1. To expose cycle program wheel, grasp timer in upper left-hand corner and pull, releasing snap retainer and swinging timer to the right.
2. To change the regeneration cycle program, the program wheel must be removed. Grasp program wheel and squeeze protruding lugs toward center, lift program wheel off timer. Switch arms may require movement to facilitate removal.
3. Return timer to closed position engaging snap retainer in back plate. Make certain all electrical wires locate above snap retainer post.

Timer Setting Procedure for 3200 & 3210 Timer

How To Change The Length Of The Backwash Time:

The program wheel as shown in the drawing is in the service position. As you look at the numbered side of the program wheel, the group of pins starting at zero determines the length of time your unit will backwash.

EXAMPLE: If there are six pins in this section, the time of backwash will be 12 min. (2 min. per pin). To change the length of backwash time, add or remove pins as required. The number of pins times two equals the backwash time in minutes.

How To Change The Length Of Brine And Rinse Time:

1. The group of holes between the last pin in the backwash section and the second group of pins determines the length of time that your unit will brine and rinse (2 min. per hole).
2. To change the length of brine and rinse time, move the rapid rinse group of pins to give more or fewer holes in the brine and rinse section. Number of holes times two equals brine and rinse time in minutes.

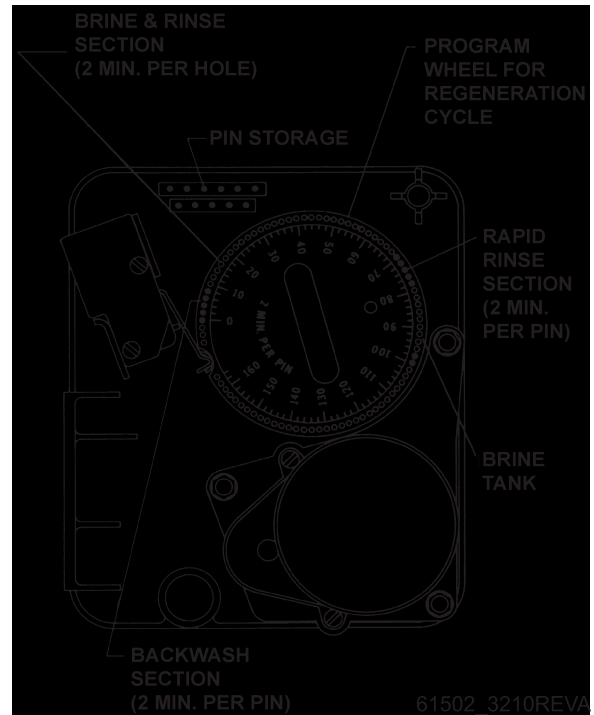

Figure 4

How To Change The Length Of Rapid Rinse:

1. The second group of pins on the program wheel determines the length of time that your water conditioner will rapid rinse (2 min. per pin).
2. To change the length of rapid rinse time, add or remove pins at the higher numbered end of this section as required. The number of pins times two equals the rapid rinse time in minutes.

How To Change The Length Of Brine Tank Refill Time:

1. The second group of holes in the program wheel determines the length of time that your water conditioner will refill the brine tank (2 min. per hole).
2. To change the length of refill time, move the two pins at the end of the second group of holes as required.
3. The regeneration cycle is complete when the outer microswitch is tripped by the two pin set at end of the brine tank refill section.
4. The program wheel, however, will continue to rotate until the inner micro-switch drops into the notch on the program wheel.

3200 Timer Assembly

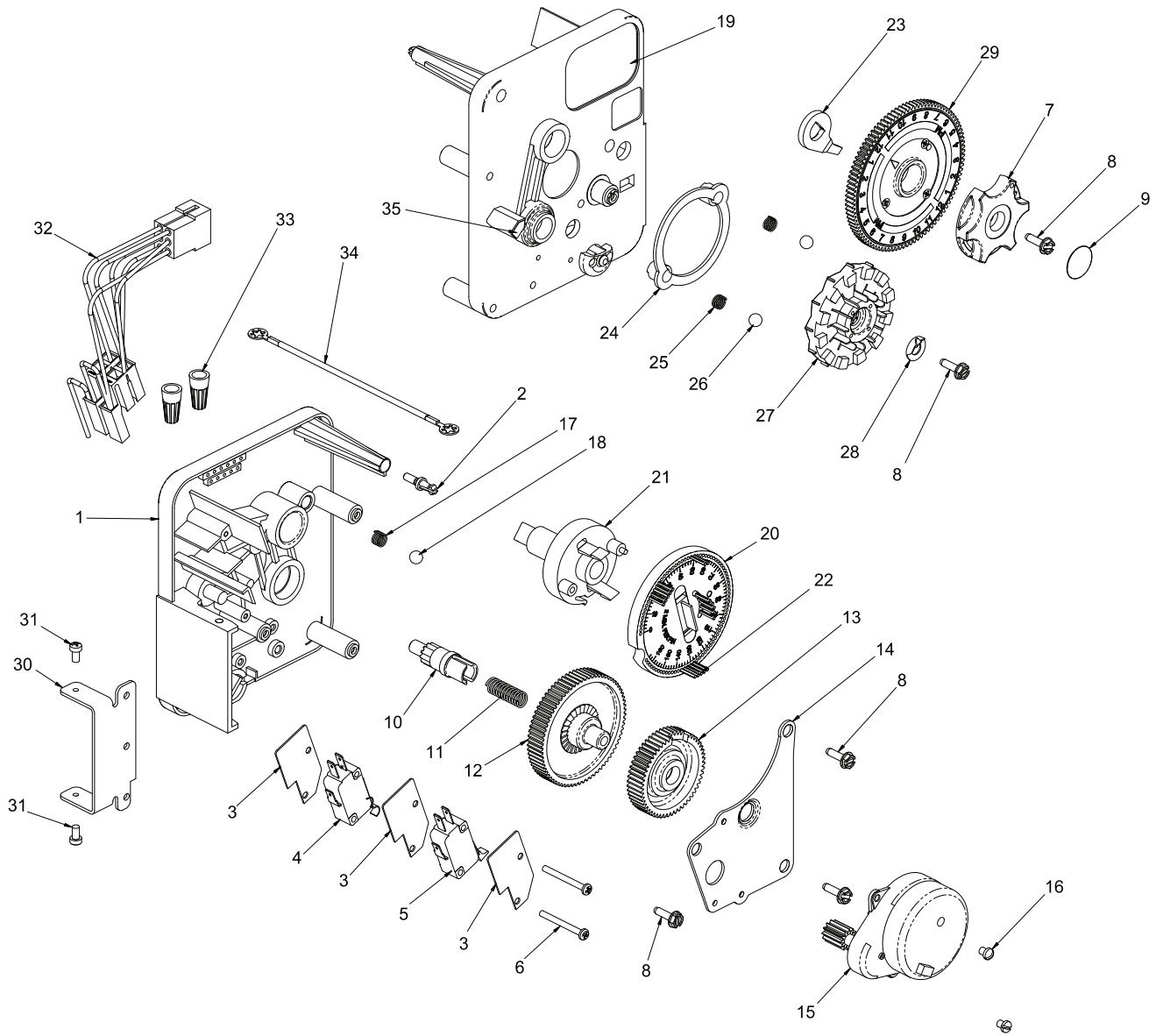

61502-3200_REVA

For Service Assembly Numbers, See the Back of this Manual

3200 Timer Assembly

Item No.	Quantity	Part No.	Description
1	1	13870	Housing, Timer, 3200
2	1	14265	Clip, Spring
3	3	14087	Insulator
4	1	10896	Switch, Micro
5	1	15320	Switch, Micro, Timer
6	2	11413	Screw, Pan Hd Mach, 4-40 x 1-1/8
7	1	13886	Knob, 3200
8	5	13296	Screw, Hex Wsh, 6-20 x 1/2
9	1	11999	Label, Button
10	1	13018	Pinion, Idler
11	1	13312	Spring, Idler Shaft
12	1	13017	Gear, Idler
13	1	13164	Gear, Drive
14	1	13887	Plate, Motor Mounting
15	1	18743-1	Motor, 120V, 60Hz, 1/30 RPM, 5600
		19659-1	Motor, 24V, 60Hz, 1/30 RPM
16	2	13278	Screw, Slt'd Fillister Hd 6-32 x .156
17	1	15424	Spring, Detent, Timer
18	1	15066	Ball, 1/4", Delrin
19	1	15465	Label, Caution
20	1	19210	Program Wheel Assy
21	1	13911	Gear, Main Driver, Timer
22	17	41754	Pin, Spring, 1/16 x 5/8 SS, Timer
23	1	13011	Arm, Cycle Actuator
24	1	13864	Ring, Skipper Wheel
25	2	13311	Spring, Detent, Timer
26	2	13300	Ball, 1/4", SS
27	1	14381	Skipper Wheel Assy, 12 Day
		14860	Skipper Wheel Assy, 7 Day
28	1	13014	Pointer, Regeneration
29	1	40096-24	Dial, 12 AM Regen Assy, Black
		40096-02	Dial, 2 AM Regen Assy, Black
30	1	13881	Bracket, Hinger Timer
31	2	11384	Screw, Phil, 6-32 x 1/4 Zinc
32	1	13902	Harness, 3200
33	2	40422	Nut, Wire, Tan
34	1	15354-01	Wire, Ground, 4"
35	1	14007	Label, Time of Day

For Service Assembly Numbers, See the Back of this Manual

3210 Timer Assembly

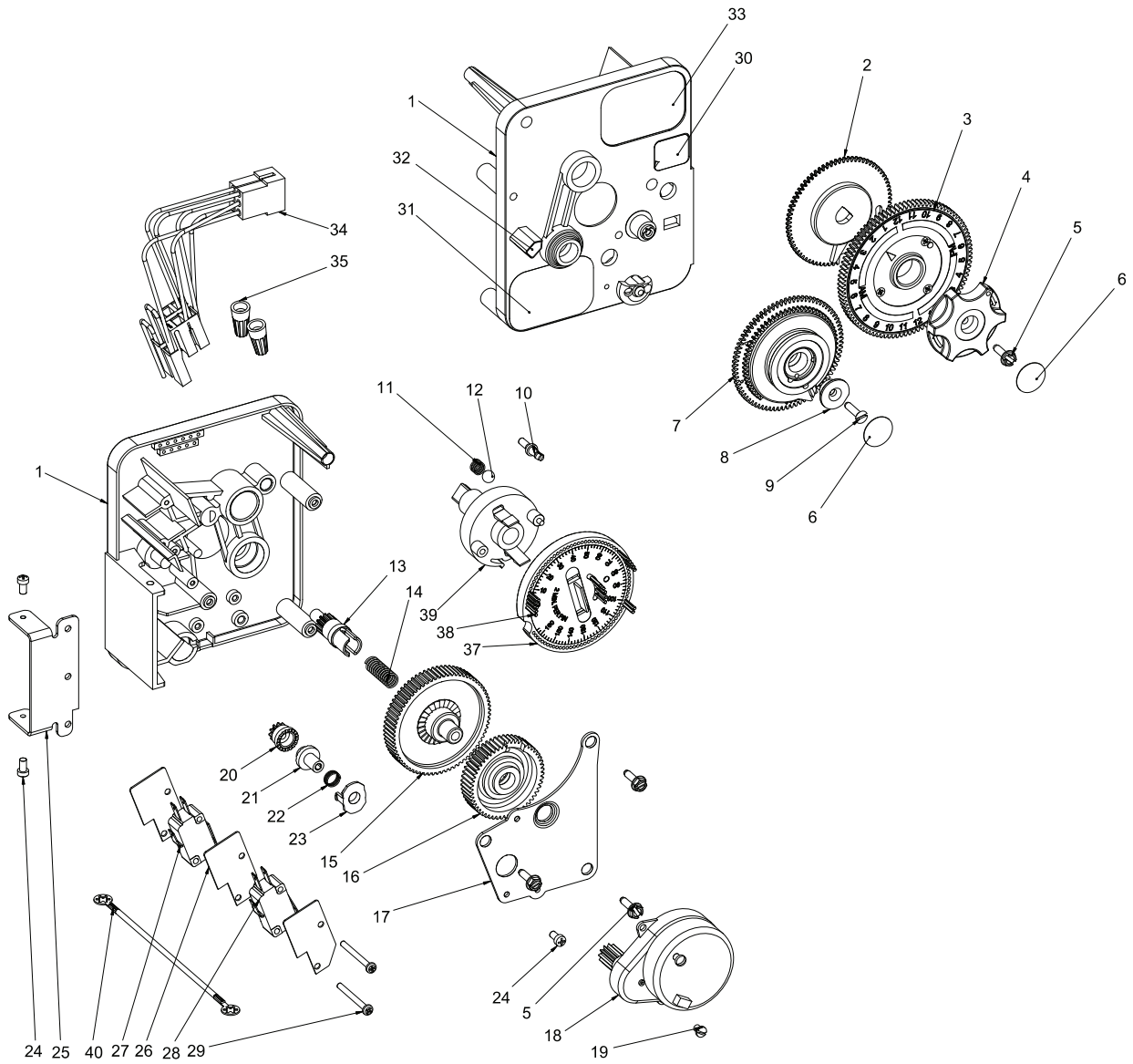

61502-3210_REVA

For Service Assembly Numbers, See the Back of this Manual

3210 Timer Assembly

Item No.	Quantity	Part No.	Description
1	1	13870	Housing, Timer, 3200
2	1	13802	Gear, Cycle Actuator
3	1	40096-02	Dial, 2 AM Regen Assy, Black
4	1	13886	Knob, 3200
5	4	13296	Screw, Hex Wsh, 6-20 x 1/2
6	2	11999	Label, Button
7	1	60405-15	Program Wheel, w/34" Std Label, w/People Label Set @21
8	1	13806	Retainer, Program Wheel
9	1	13748	Screw, Flat Head St, 6-20 x 1/2
10	1	14265	Clip, Spring
11	1	15424	Spring, Detent, Timer
12	1	15066	Ball, 1/4" Delrin
13	1	13018	Pinion, Idler
14	1	13312	Spring, Idler Shaft
15	1	13017	Gear, Idler
16	1	13164	Gear, Drive
17	1	13887	Plate, Motor Mounting
18	1	18743-1	Motor, 120V, 60Hz 1/30 RPM, 5600
19	1	13278	Screw, Fillister Hd, 6-32 x .156
20	1	13830	Pinion, Program Wheel Drive
21	1	13831	Clutch, Drive Pinion
22	1	14276	Spring, Meter, Clutch
23	1	14253	Retainer, Clutch Spring
24	3	11384	Screw, Phil, 6-32 x 1/4
25	1	13881	Bracket, Hinge Timer
26	3	14087	Insulator
27	1	10896	Switch, Micro
28	1	15320	Switch, Micro, Timer
29	2	11413	Screw, Pan Hd Mach, 4-40 x 1-1/8
30	1	14198	Label, Indicator
31	1	15465	Label, Caution
32	1	14007	Label, Time of Day
33	1	14045	Label, Instruction
34	1	13902	Harness, 3200
35	2	40422	Nut, Wire, Tan
36	1	15354-01	Wire, Ground, 4"
37	1	19210	Program Wheel Assy
38	17	41754	Pin, Spring, 1/16 x 5/8 SS Timer
39	1	13911	Gear, Main Drive, Timer
40	1	15354-01	Wire, Ground 4"

For Service Assembly Numbers, See the Back of this Manual

Powerhead Assembly (Designer)

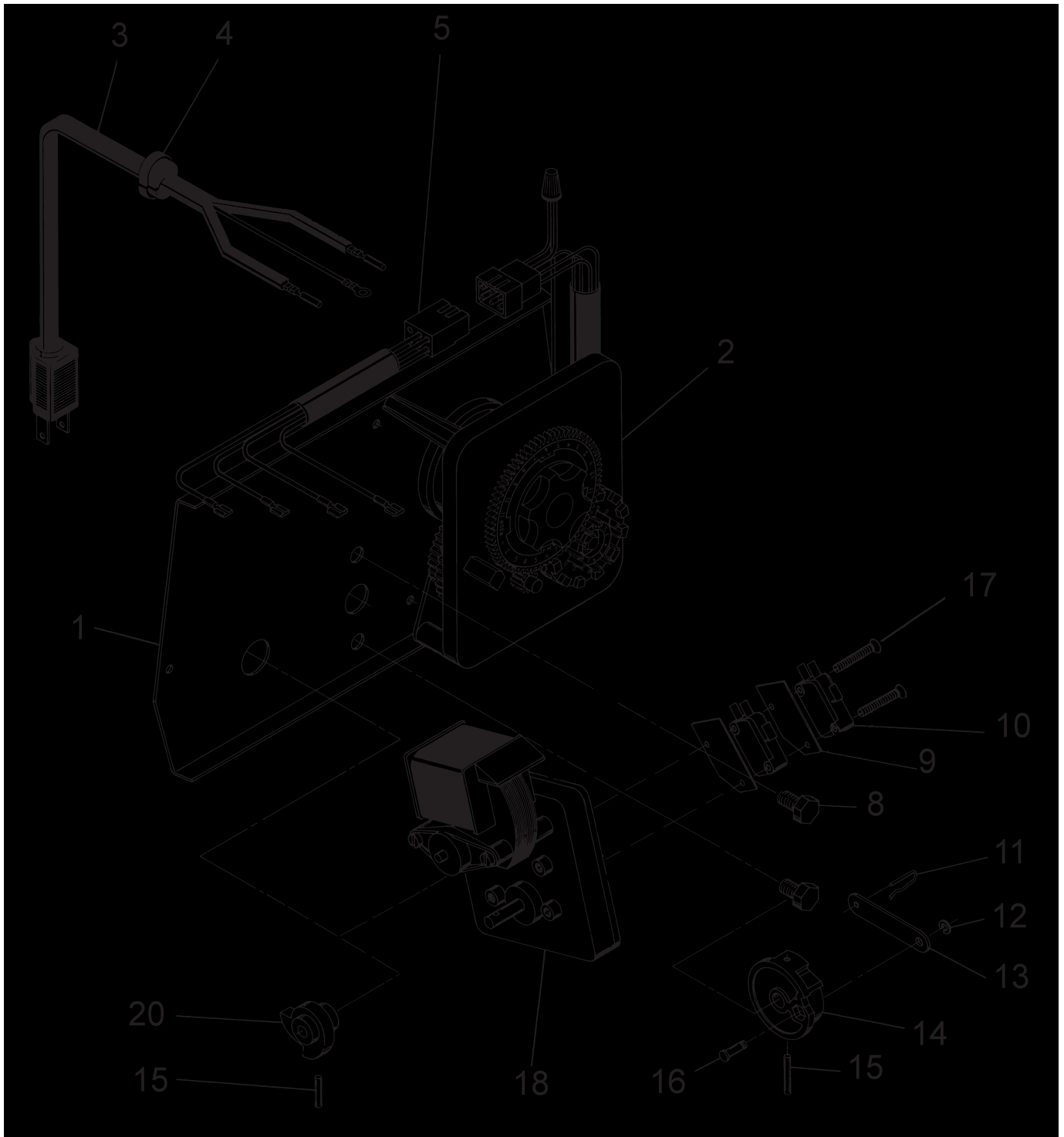

61501_2510REVB

For Service Assembly Numbers, See the Back of this Manual

Powerhead Assembly (Designer)

Item No.	Quantity	Part No.	Description
1	1	40264	Backplate, SS/SVO, W-T-Screws
2	1		3200, Timer 7 or 12 Day
3	1	11838	Power Cord
4	1	13547	Strain Relief
5	1	40400	Harness, Drive, Designer/Environmental
8	2	10231	Screw, Drive Mounting
9	2	10302	Insulator
10	2	10218	Switch
11	1	10909	Connecting Link Pin
12	1	10250	Retaining Ring
13	1	10621	Connecting Link
14	1	12576	Drive Cam, STF (Black)
	1	12102	Drive Cam, RR (White)
15	2	10338	Roll Pin
16	1	13366	Drive Bearing
17	2	14923	Screw, Switch Mounting
18	1	41543*	Motor, Drive, 115V, 50/60Hz
		42579**	Motor, Drive, 24VAC/VDC, 50/60Hz
		41545*	Motor, Drive, 230V, 50/60Hz
20	1	12777	Brine Valve Cam, STF (Black)
	1	10815	Brine Valve Cam, RR (White)

Not Shown:

	2	10300	Screw, Timer Mounting
	1	13741	Hole Plug
	1	17904	Hole Plug
	2	19367	Screw, Thumb
	1	15441	Meter Cable Guide Assy (Econominder Only)
	1	15495	Meter Cable, 13.87" (Econominder Only)
	1	60232-110	Cover, Designer, 1 Pc, Black

* Bracket is integrated into the motor.

** Bracket is integrated into motor. Picture may not reflect component.

For Service Assembly Numbers, See the Back of this Manual

Powerhead Assembly (Environmental)

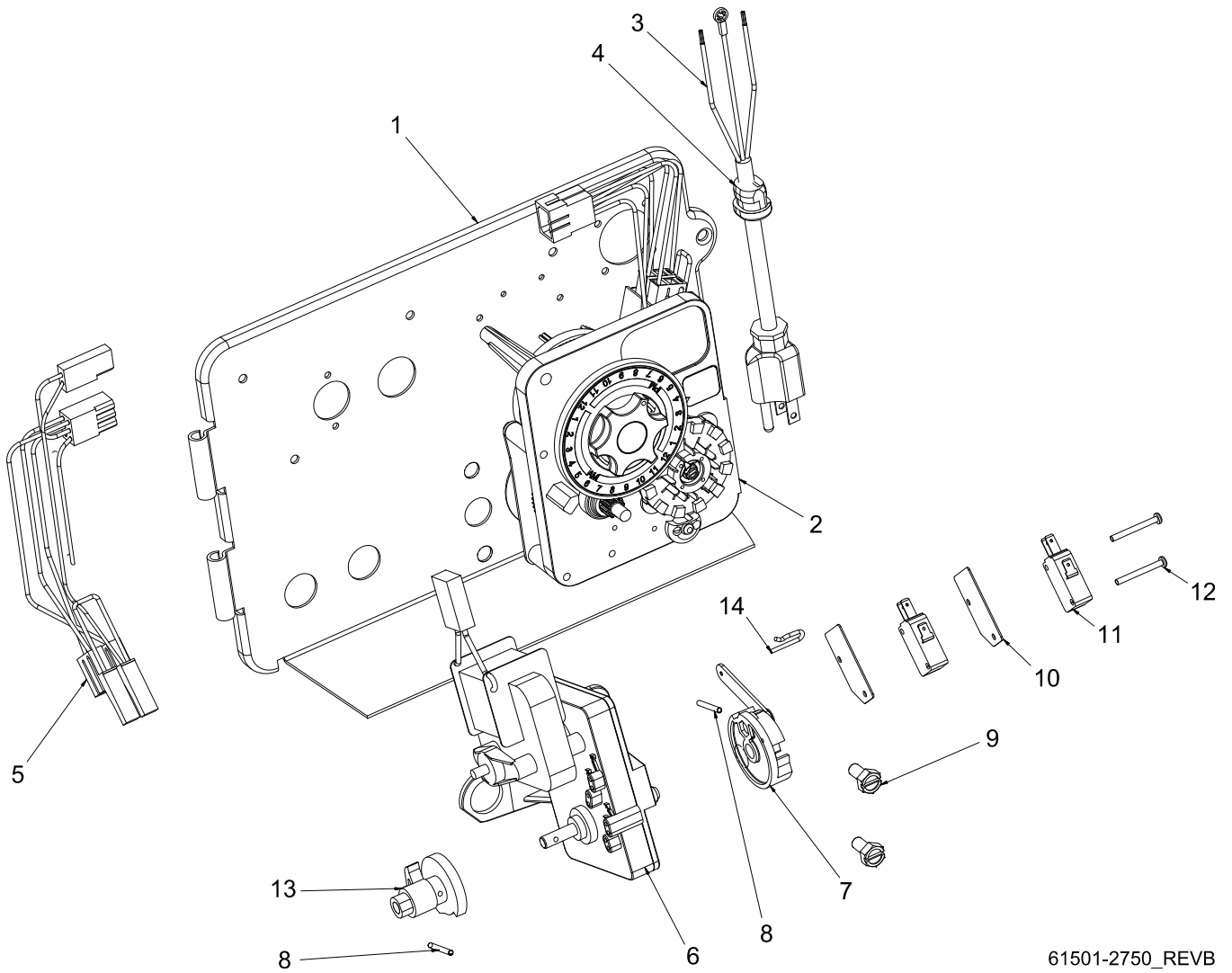

61501-2750_REVB

For Service Assembly Numbers, See the Back of this Manual

Powerhead Assembly (Environmental)

Item No.	Quantity	Part No.	Description
1.....	1	18697-15	Backplate, Hinged, 2900
2.....	1		Timer: - 3200 7 Day - 3200 12 Day - 3210 Meter
3.....	1	11839.....	Power Cord, 12' Fleck
4.....	1	13547.....	Strain Relief, Flat Cord
5.....	1	40400.....	Harness, Drive, Designer/Environmental
6.....	1	41543*	Motor, Drive, 115V, 50/60 Hz
		42579**	Motor,
		41545*	Motor,
7.....	1	60160-15	Drive Cam Assy, STF, Blue, 2900
8.....	2	10338.....	Pin, Roll, 8/32 x 7/8
9.....	2	10231.....	Screw, Slot Hex, 1/4 - 20 x 1/2
10.....	2	10302.....	Insulator, Limit Switch
11.....	2	10218.....	Switch, Micro
12.....	2	14923.....	Screw, Pan Hd Mach, 4-40 x 1
13.....	2	12777.....	Cam, Shut-Off Valve
14.....	1	10909.....	Pin, Link

Not Shown:

1	15441.....	Cable Guide Assy, 2750, 2510
1	15495.....	Meter Cable, 13.87"
1	13741.....	Plug, 3/4", Knock-Out
1	15806.....	Plug, Hole, Heyco #2693
1	16493.....	Plug, Hole, Heyco
1	17421.....	Plug, 1.20 Hole Heyco #2733
2	19691.....	Plug, .750 Dia, Recessed, Black
7	19800.....	Plug, .140 Dia, White
4	19801.....	Plug, .190 Dia, White
2	10300.....	Screw, Slot Hex Wsh, 8-18 x 3/8
1	10872.....	Screw, Hex Wsh, 8-32 x 17/64
1	60219-02	Cover Assy, Environmental, Black w/Clear Window

* Bracket is integrated into the motor.

** Bracket is integrated into motor. Picture may not reflect component.

For Service Assembly Numbers, See the Back of this Manual

Manual Powerhead Assembly

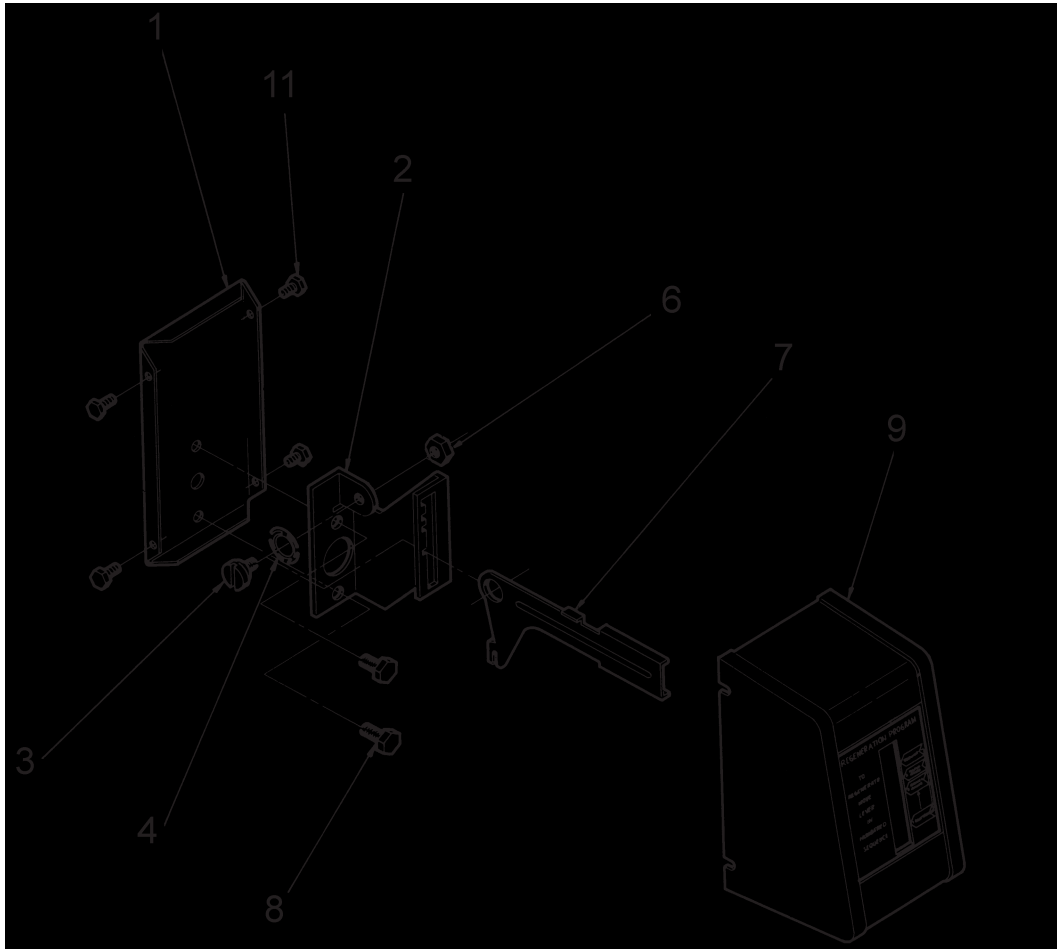

60409REVA

Item No.	Quantity	Part No.	Description
1	1	12593	Backplate, Manual
2	1	12592	Bracket, Lever Position
3	1	12596	Screw, Spec Mach, 1/4 - 20 x 1/2
4	1	12707	Washer, Spring
6	1	11235	Nut, Hex, 1/4 - 20, Mach Screw, Zinc
7	1	12594	Lever, Valve Position
8	2	10231	Screw, Slot Hex, 1/4 - 20 x 1/2 18-8 SS
9	1	60224-32	Cover Assy, Manual, Filter
	1	60224-33	Cover Assy, Manual, Softener
11	4	10300	Screw, Slot Hex Wsh, 8-18 x 3/8 Type "B" RC44-47

Not Shown:

..... 1.....10909.....Pin, Link

For Service Assembly Numbers, See the Back of this Manual

Control Valve Assembly

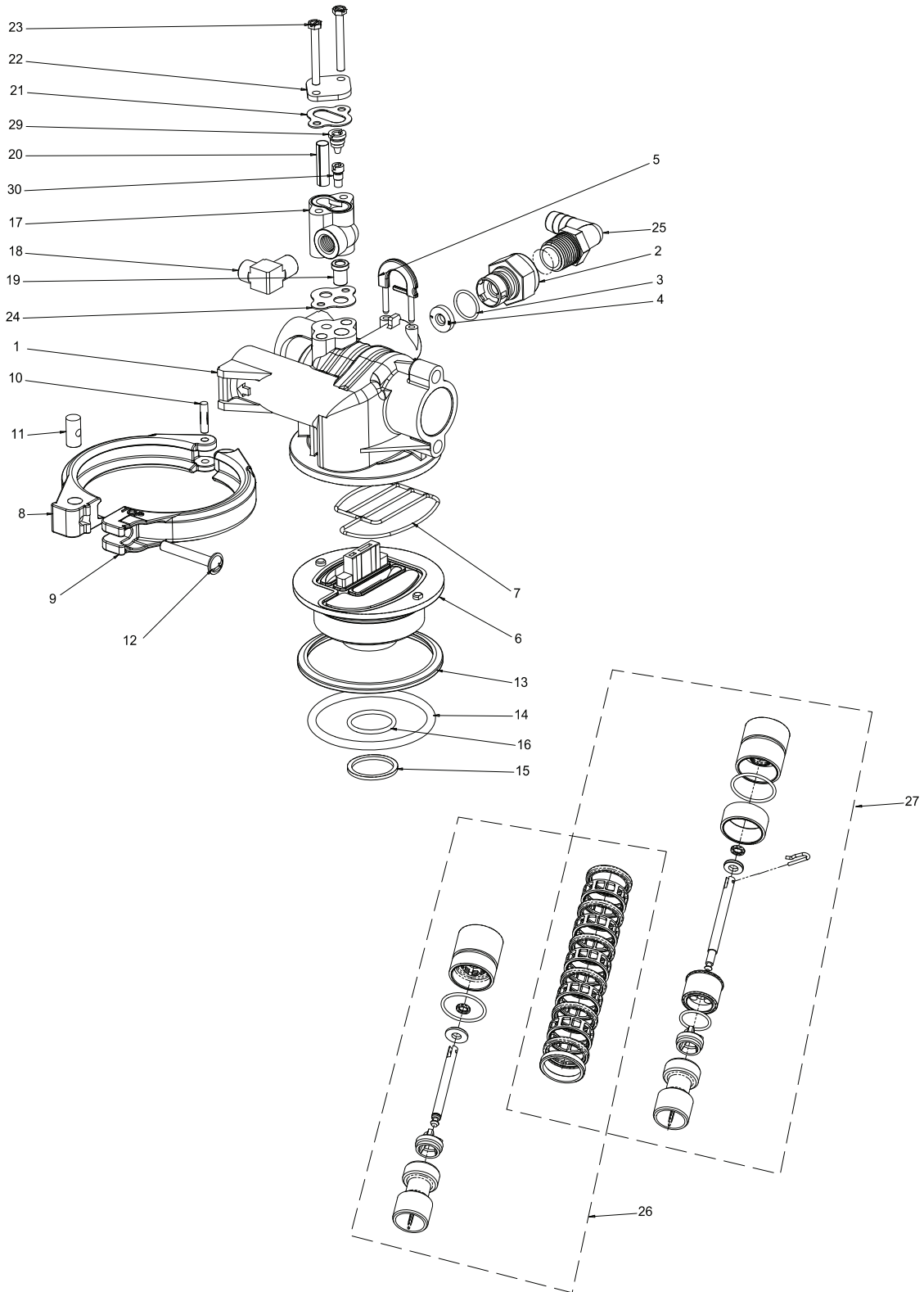

61500_2510REVB

For Service Assembly Numbers, See the Back of this Manual

Control Valve Assembly

Item No.	Quantity	Part No.	Description
1	1	19328	Valve Body, 2510
2	1	11385-01	Housing, Flow Control, Plastic
3	1	11183	O-ring, -017
4	1	12408	Washer, Flow, 7.0 GPM
5	1	18312	Retainer, Drain
6	1	19322	Adapter Base, 2510
7	1	19936	Seal, 2510, Base
8	1	19899	Clamp, Female, 2510
9	1	19900	Clamp, Male, 2510
10	1	40000	Pin, Hinge, Clamp
11	1	19998	Pivot, Clamp, 2510
12	1	40057	Screw, Comb Hd, 114-20, 2"
13	1	19197	Ring, Slip
14	1	18303	O-ring, -336
15	1	13030	Retainer, Dist Tube, O-ring
16	1	13304	O-ring, -121
17	1	17776	Body, Injector, 1600
18	1	10328	Fitting, Elbow, 90 Deg.
19	1	16221	Disperser, Air
20	1	10227	Screen, Injector
21	1	10229	Gasket, Injector Cap, 1600
22	1	11893	Cap, Injector, SS
23	2	10692	Screw, Slot Hex Hd, 10-24x
24	1	14805	Gasket, Injector Body, 1600/1700
25	1	12338	Fitting, Elbow, 90 Deg.
26	1	61670-00	Piston Assy w/Seal & Spacer Kit 2510 Piston
27	1	61670-01	Piston Assy w/Seal & Spacer Kit 2510 Piston NHWBP
28	1	10757	Spacer, End
29	1	12973-3	Nozzle, Injector, #3, PVC
30	1	12974-3	Throat, Injector, #3, PVC

NOTE: For optimal seal life, the use of lubricants is not recommended.

For Service Assembly Numbers, See the Back of this Manual

Softener & Filter Conversion Kits

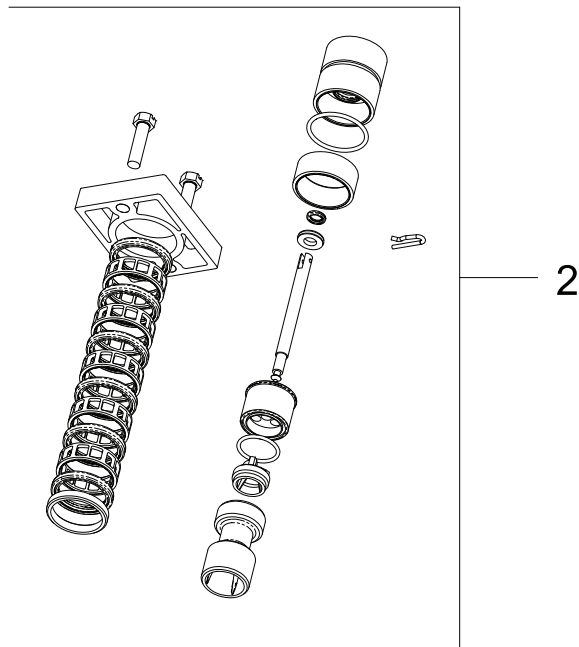
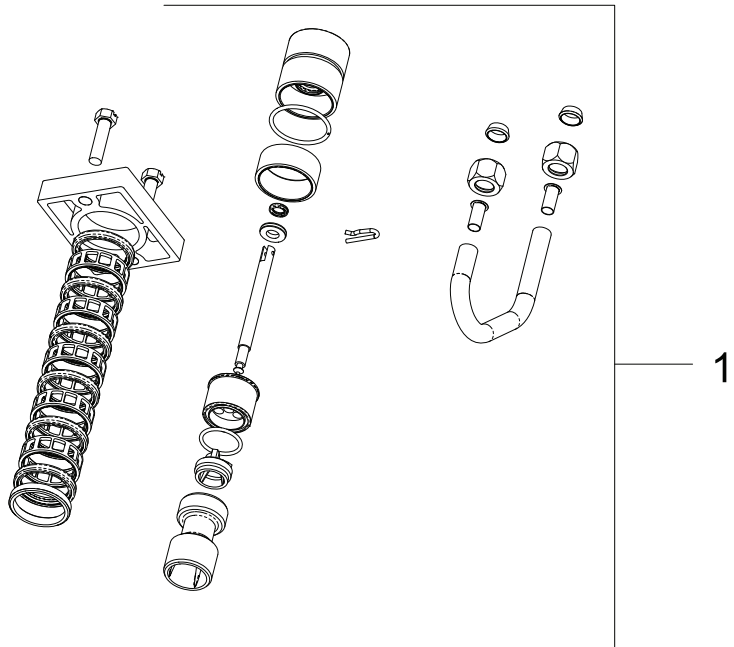

61671REVC

Item No.	Part No.	Description
1	61671-01	Piston Conversion w/Seal & Spacer 2510 NHWBP 1600
2	61671-00	Piston Kit w/Seal & Spacer 2510 NHWBP Filter

NOTE: For optimal seal life, the use of lubricants is not recommended.

Meter Assembly

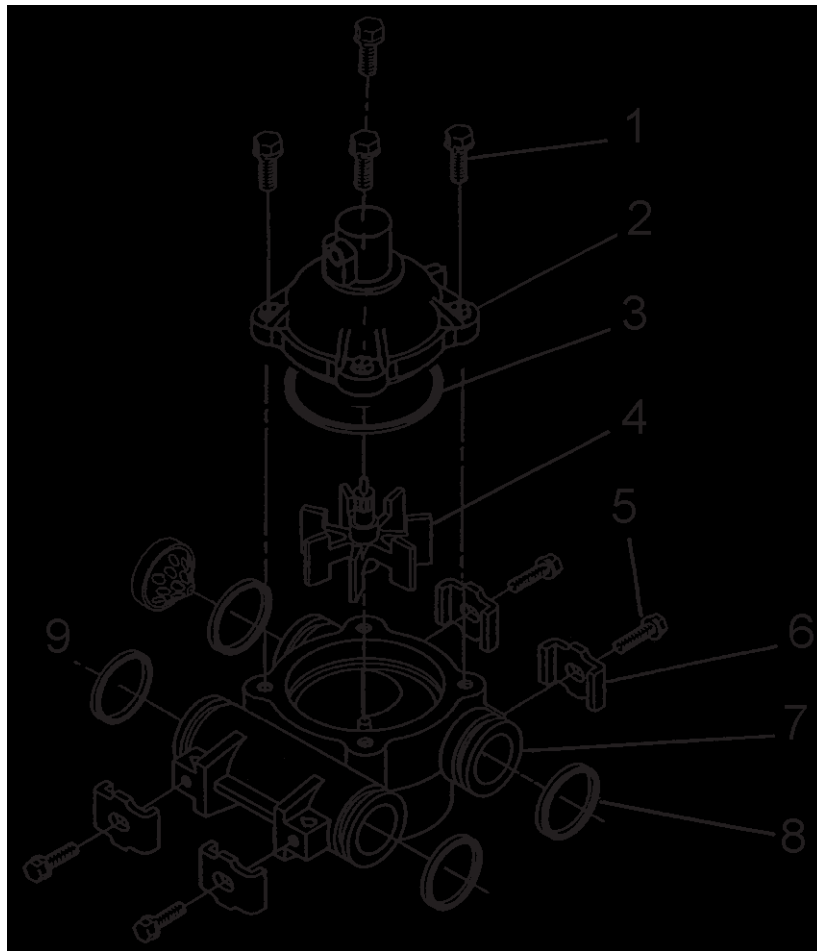

60088

Item No.	Quantity	Part No.	Description
1	4	12473	Screw - Meter Cover Assembly
2	1	15659	Meter Cover Assy. - Ext., Rt. Angle (Not Shown)
	1	15452	Meter Cap Assy, 3/4" to 2", Std, Rt Ang/90, Plastic Paddle
3	1	13847	O-ring - Meter Cover Assembly
4	1	13509	Impeller
5	4	13314	Screw - Adapter Clip
6	4	13255	Adapter Clip
7	1	13821	Meter Body
8	4	13305	O-ring - Meter Body
9	1	14613	Flow Straightener

For Service Assembly Numbers, See the Back of this Manual

1600 Brine System Assembly

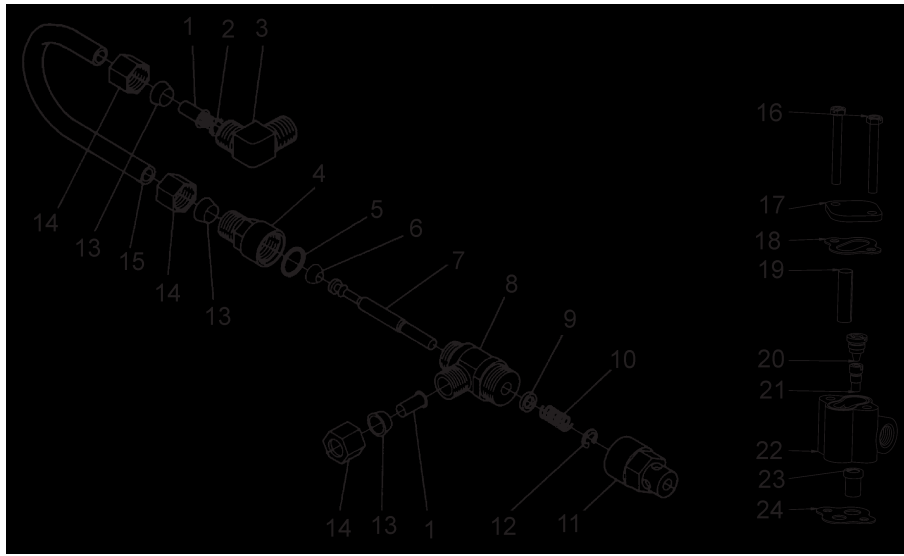

60029REV C

Item No.	Quantity	Part No.	Description
1	2	10332	Fitting, Insert, 3/8
2	1	12767	Screen, Brine
3	1	10328	Fitting, Elbow, 90 Deg. 1/4 PT x 3/8 Tube
4	1	60020-25	BLFC, .25 GPM, 1600
4	1	60020-50	BLFC, .50 GPM, 1600
4	1	60020-100	BLFC, 1.0 GPM, 1600
5	1	11982	O-ring, -016
6	1	12626	Seat, Brine Valve
7	1	12552	Brine Valve Stem, 1600
8	1	12748	Brine Valve Body Assy, 1600 w/Quad Ring
9	1	12550	Quad Ring, -009
10	1	10249	Spring, Brine Valve
11	1	11749	Guide, Brine Valve Stem
12	1	10250	Ring, Retaining
13	3	10330	Fitting, Sleeve, 3/8 Celcon
14	3	10329	Fitting, Tube, 3/8 Nut, Brass
15	1	16508-01	Tube, Brine Valve, 2850/1600
	1	12774	Tube, Brine Valve, 1500
	1	40027	Tube, Brine Valve, 2510
	1	15221	Tube, Brine Valve, 2750
	1	42184	Tube, Brine Valve, 2850s
	1	41683*	Tube, Brine Valve, UF, 1600/1650
16	2	10692	Screw, Slot Hex Hd, 10 - 24X 18-8 SS
17	1	11893	Cap, Injector, SS
18	1	10229	Gasket, Injector Cap, 1600
19	1	10227	Screen, Injector
20	1	10913	Nozzle, Injector
21	1	10914	Throat, Injector
22	1	17776	Body, Injector, 1600
	1	17776-02*	Body, Injector, 1600 Upflow
23	1	16221	Disperser, Air
24	1	14805	Gasket, Injector Body, 1600/1700

*Upflow Only

For Service Assembly Numbers, See the Back of this Manual

1650 Brine System

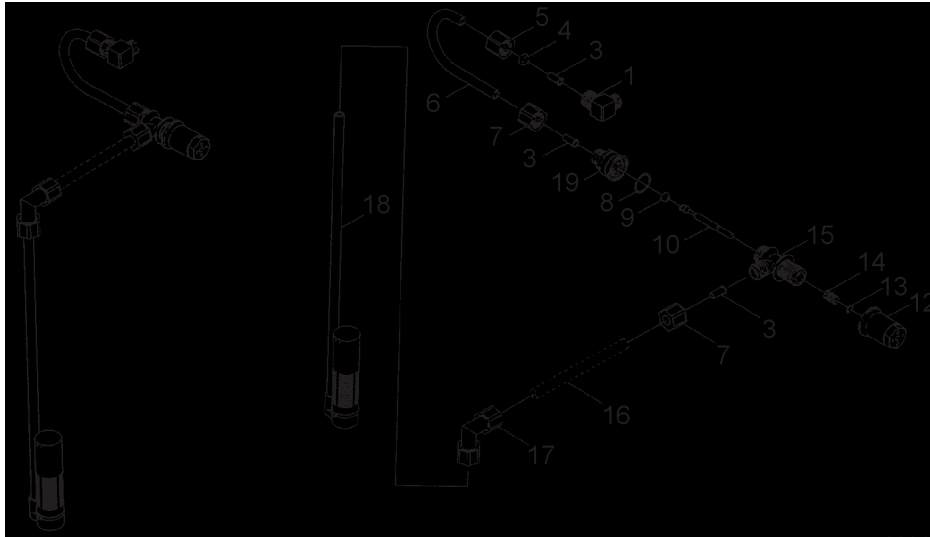

60011

Item No.	Quantity	Part No.	Description
60011 Brine Valve Assembly, Includes Items 3-15 (Less BLFC 60010-)			
1	1	10328	Elbow, 90 1/4 NPT x 3/8
3	3	10332	Insert, 3/8
4	1	10330	Sleeve, 3/8 Nut Brine
5	1	10329	Tube Fitting, 3/8 Nut Brine
6	1	40027	Tube, Brine Valve
7	2	19625	Assy., GFN Nut
8	1	16924	O-ring
9	1	12626	Seat, Brine Valve
10	1	12552	Brine Valve Stem, 1600
12	1	17906	Guide, Brine Valve Stem
13	1	10250	Retaining Ring
14	1	10249	Spring, Brine Valve
15	1	17884	Brine Valve Body Assy., Plastic
17	1	12794	Elbow, 3/8 Tube Poly, White
18	1	60002	#500 Air Check
19	1	60010-xx	BLFC Assy.

60010-25 BLFC Assy. (Parts)

1	17907	Housing
1	12128	25 GPM Label
1	12094	25 Flow Washer
1	12098	Retainer

60010-50 BLFC Assy. (Parts)

1	17907	Housing
1	10759	50 GPM Label
1	12095	50 Flow Washer
1	12098	Retainer

60010-100 BLFC Assy. (Parts)

1	17907	Housing
1	10760	1.0 GPM Label
1	12097	1.0 Flow Washer
1	12098	Retainer

For Service Assembly Numbers, See the Back of this Manual

Bypass Valve Assembly (Plastic)

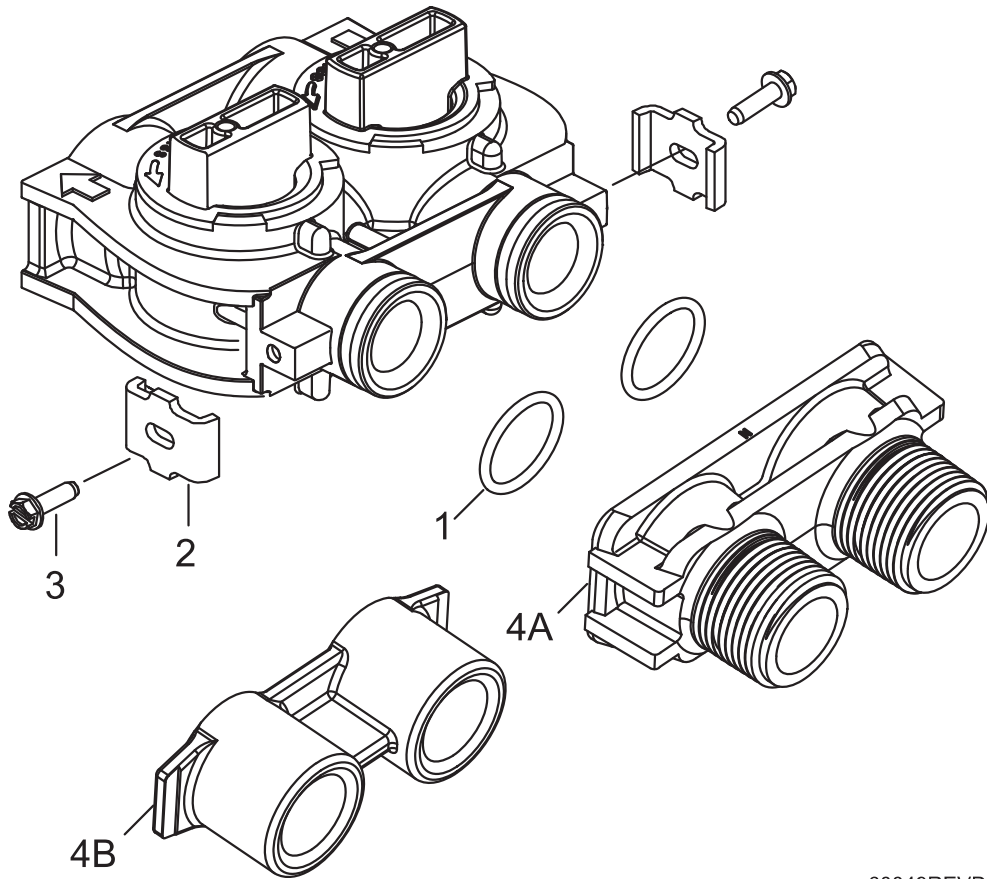

60049REVD

Item No.	Quantity	Part No.	Description
1	2	13305	O-ring, -119
2	2	13255	Clip, Mounting
3	2	13314	Screw, Slot Ind Hex, 8-18 x .60
4A	1	18706	Yoke, 1", NPT, Plastic
		18706-02	Yoke, 3/4", NPT, Plastic
4B	1	13708-40	Yoke, 1", Sweat
		13708-45	Yoke, 3/4", Sweat
		19275	Yoke, Angle 90 Deg, 3/4", NPT
		19275-45	Yoke, Angle 90 Deg, 3/4" Sweat
		19620-01	Yoke Assy, 3/4", R/Angle, 90 Deg w/O-rings, Clips & Screws
		40636	Yoke, 1 1/4", NPT
		40636-49	Yoke, 1 1/4", Sweat
		41027-01	Yoke, 3/4", NPT, Cast, Machined
		41026-01	Yoke, 1", NPT, Cast, Machined, SS

For Service Assembly Numbers, See the Back of this Manual

Bypass Valve Assembly (Metal)

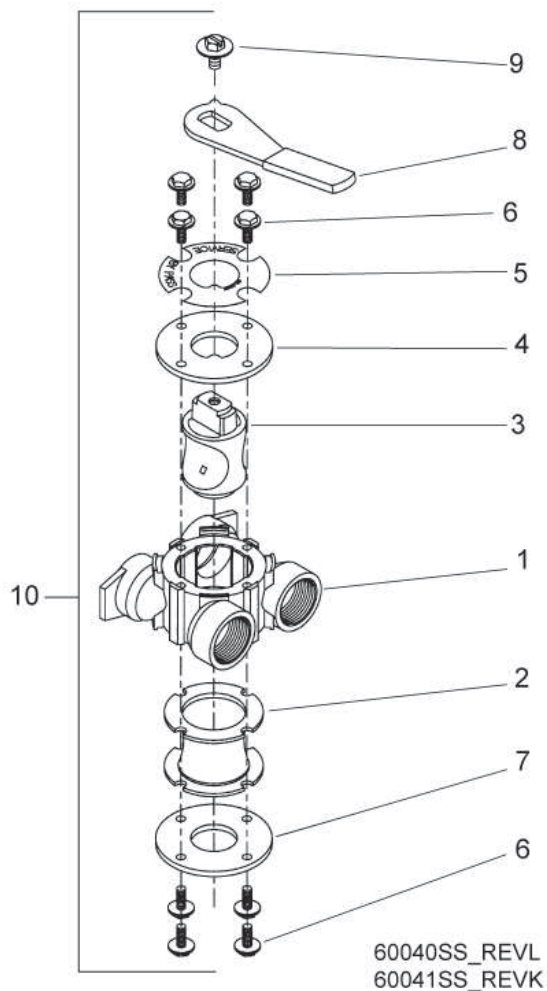

Item No.	Quantity	Part No.	Description
1	1	40614	Bypass Body, 3/4"
		40634	Bypass Body, 1", SS
2	1	14105	Seal, Bypass, 560CD
3	1	11972	Plug, Bypass
4	1	11978	Side Cover
5	1	13604-01	Label
6	8	15727	Screw
7	1	11986	Side Cover
8	1	11979	Lever, Bypass
9	1	11989	Screw, Hex Head, 1/4-14
10	1	60040SS	Bypass Valve, 5600, 3/4" NPT Blk Grip Lever, SS
		60041SS	Bypass Valve, 5600, 1" NPT Blk Grip Lever, SS

For Service Assembly Numbers, See the Back of this Manual

2300 Safety Brine Valve

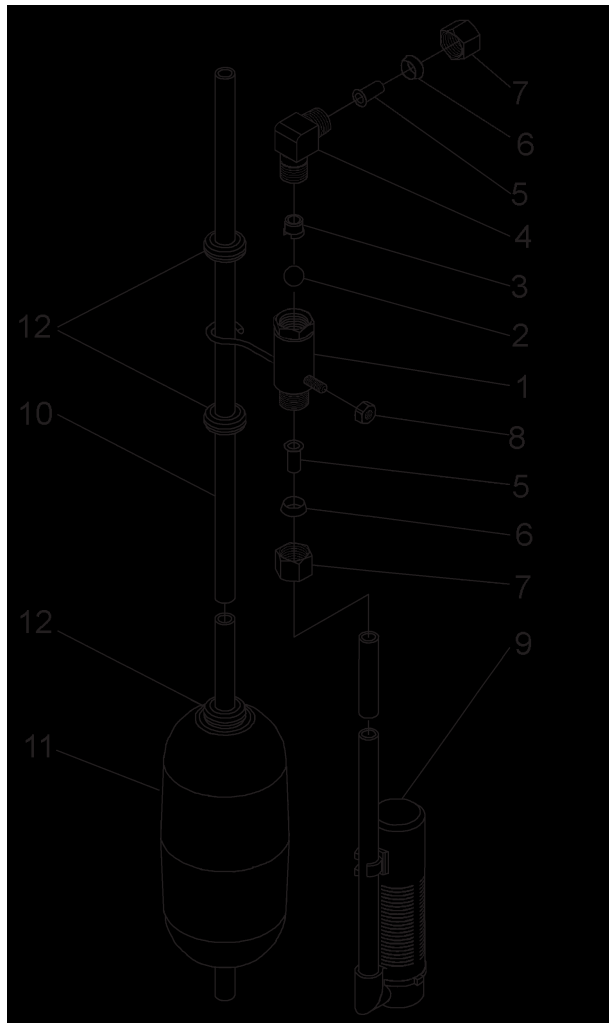

60027REVA

Item No.	Quantity	Part No.	Description
1	1	60027-00	Safety Brine Valve, 2300, Less Elbow
2	1	10138	Ball, 3/8", Brass
3	1	11566	Ball Stop, Slow Fill
4	1	10328	Fitting, Elbow, 90 Deg. 1/4 NPT x 3/8 Tube
5	1	10332	Fitting, Insert, 3/8
6	1	10330	Fitting, Sleeve, 3/8 Celcon
7	1	10329	Fitting, Tube, 3/8 Nut, Brass
8	1	10186	Nut, Hex, 10-32
9	1	60002-34	Air Check, #500, 34" Long
		60003-34	Air Check, #500, HW, 34" Tube
10	1	10149	Rod, Float
11	1	10700	Float Assy, White
12	3	10150	Grommet, .30 Dia

For Service Assembly Numbers, See the Back of this Manual

2310 Safety Brine Valve

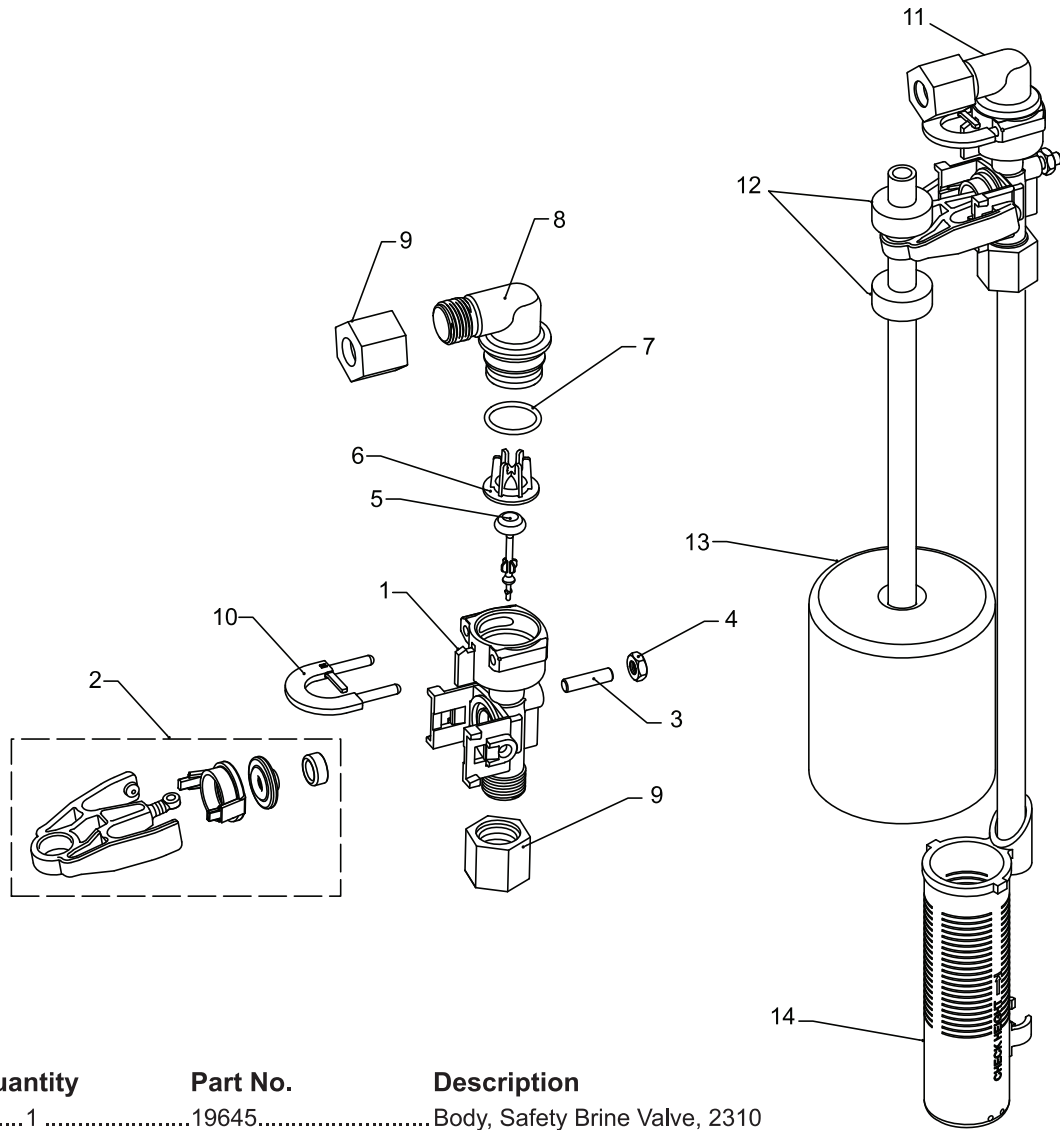

42112_REVA

Item No.	Quantity	Part No.	Description
1	1	19645	Body, Safety Brine Valve, 2310
2	1	19803	Safety Brine Valve Assy
3	1	19804	Screw, Sckt Hd, Set, 10-24 x .75
4	1	19805	Nut, Hex, 10-24, Nylon Black
5	1	19652-01	Poppet Assy, SBV w/O-ring
6	1	19649	Flow Dispenser
7	1	11183	O-ring, -017
8	1	19647	Elbow, Safety Brine Valve
9	2	19625	Nut Assy, 3/8" Plastic
10	1	18312	Retainer, Drain
11	1	60014	Safety Brine Valve Assy, 2310
12	2	10150	Grommet, .30 Dia
13	1	60068-30	Float Assy, 2310, w/30" Rod
14	1	60002-34	Air Check, #500, 34" Long

For Service Assembly Numbers, See the Back of this Manual

Service Instructions

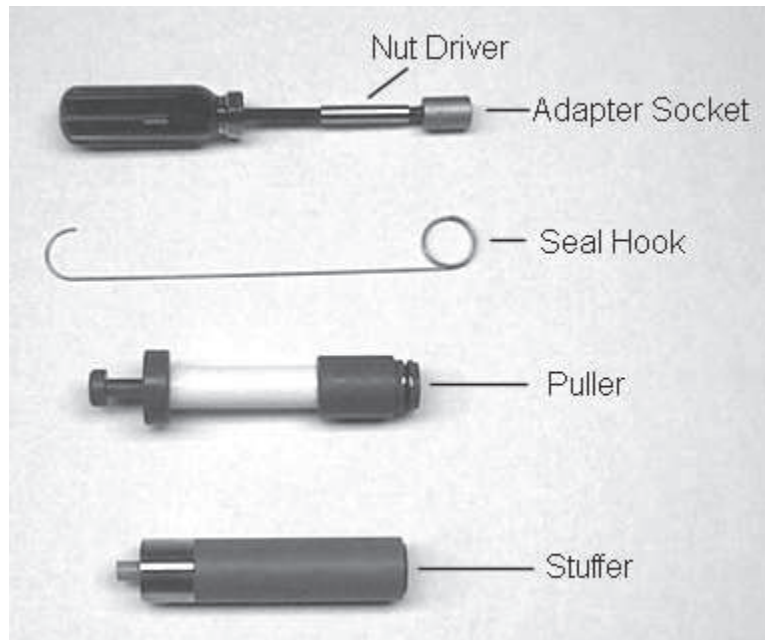

Tools Used in the Seal and Spacer Replacement

Description	Part No.
Nut Driver	12664
Socket Adapter	16906
Socket 7/16"	12665
Seal Hook	12874
Puller	13061
Stuffer	11098

Seal & Spacer Replacement

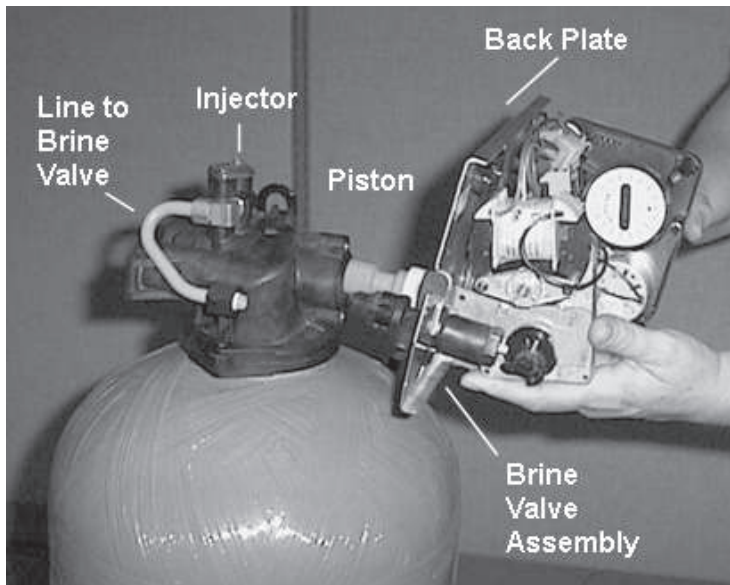

Figure 5

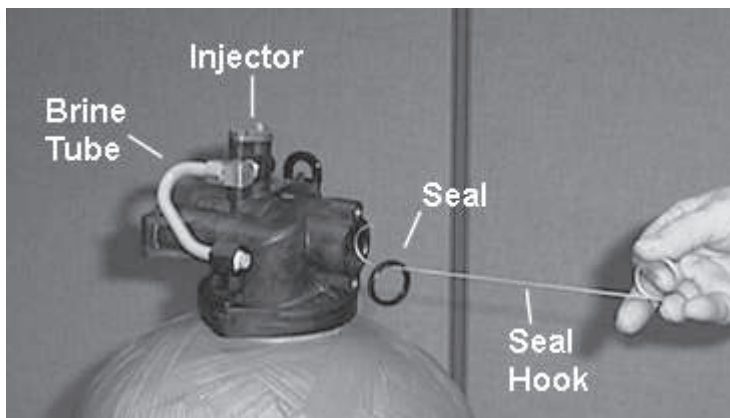

Figure 6

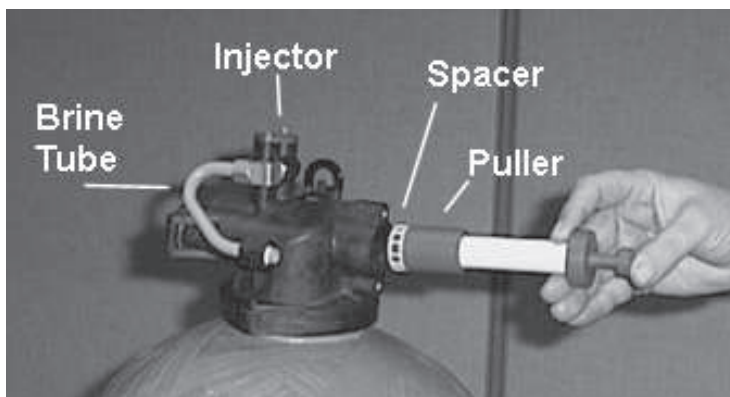

Figure 7

1. Turn off water supply to valve. Next, cycle valve to backwash position, then to service. Now remove electrical plug from outlet.
2. Remove control box cover.
3. Disconnect the brine line from the injector housing to the brine valve (if your unit has timed brine tank fill).
4. Remove the two capscrews that hold the back plate to the valve.
5. Grasp the back plate on both sides and slowly pull end plug and piston assembly out of the valve body (see Figure 5) and lay aside.
6. Remove the seal first using the wire hook with the finger loop (see Figure 6).
7. The spacer tool (use only for removing the spacers) has three retractable pins, retained by a rubber ring, at one end; they are retracted or pushed out by pulling or pushing the center button the opposite end.
8. Insert the pin end of the spacer tool into the valve body with the pins retracted (button pulled back). Push the tool tight against the spacer and push the button in (see Figure 7). When the button is pushed in, the pins are pushed out to engage the 1/4 dia. holes in the spacer. Remove the tool from the valve body. The spacer will be on the end. Pull the center button back, the pins will be retracted and the spacer can be removed from the spacer tool.

Seal & Spacer Replacement

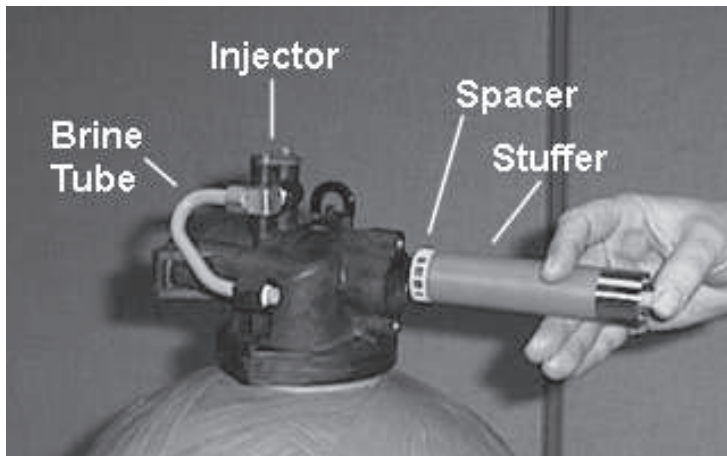

Figure 8

9. Alternately remove the remaining seals and spacers in accordance with steps No. 6 and 8.
10. The last or end spacer does not have any holes for the pins of the spacer tool to engage, therefore if the end spacer does not come out on the first try, try again using the wire hook with the finger loop.
11. To replace seals, spacers and end ring, use special tool with the brass sleeve on one end. This is a double-purpose tool (see Figure 8). The male end acts as a pilot to hold the spacers as they are pushed into the valve body and the brass female end is used to insert the seals into the valve body.
12. To restuff a valve body, first take the end ring (the plastic or brass ring without holes), then with your thumb press the button on the brass sleeve end, the large dia. inner portion is now exposed (see Figure 8). Place the end ring on this pilot with the lip on the end ring facing the tool, and push the tool into the valve body bore until it bottoms. While the tool is in the valve body, take a seal and press it into the inside diameter of the exposed brass female end.
13. Remove the tool, turn it end for end and insert it into the valve body bore. While holding the large dia. of the tool, slide it all the way into the valve body bore until it bottoms, then push the center button to push the seal of the tool and leave it in place in the valve body.
14. Remove the tool from the valve body and push the center on the brass female end to expose the pilot on the opposite end. Place a spacer on this end and insert the spacer and tool into the valve.

Troubleshooting

Problem	Cause	Correction
1. Water conditioner fails to regenerate.	A. Electrical service to unit has been interrupted	A. Assure permanent electrical service (check fuse, plug, pull chain, or switch)
	B. Timer is defective.	B. Replace timer.
	C. Power failure.	C. Reset time of day.
2. Hard water.	A. By-pass valve is open.	A. Close by-pass valve.
	B. No salt is in brine tank.	B. Add salt to brine tank and maintain salt level above water level.
	C. Injector screen plugged.	C. Clean injector screen.
	D. Insufficient water flowing into brine tank.	D. Check brine tank fill time and clean brine line flow control if plugged.
	E. Hot water tank hardness.	E. Repeated flushings of the hot water tank is required.
	F. Leak at distributor tube.	F. Make sure distributor tube is not cracked. Check O-ring and tube pilot.
	G. Internal valve leak.	G. Replace seals and spacers and/or piston.
3. Unit used too much salt.	A. Improper salt setting.	A. Check salt usage and salt setting.
	B. Excessive water in brine tank.	B. See problem 7.
4. Loss of water pressure.	A. Iron buildup in line to water conditioner.	A. Clean line to water conditioner.
	B. Iron buildup in water conditioner.	B. Clean control and add mineral cleaner to mineral bed. Increase frequency of regeneration.
	C. Inlet of control plugged due to foreign material broken loose from pipes by recent work done on plumbing system.	C. Remove piston and clean control.
5. Loss of mineral through drain line.	A. Air in water system.	A. Assure that well system has proper air eliminator control. Check for dry well condition.
	B. Improperly sized drain line flow control.	B. Check for proper drain rate.
6. Iron in conditioned water.	A. Fouled mineral bed.	A. Check backwash, brine draw, and brine tank fill. Increase frequency of regeneration. Increase backwash time.
7. Excessive water in brine tank.	A. Plugged drain line flow control.	A. Clean flow control.
	B. Plugged injector system.	B. Clean injector and screen.
	C. Timer not cycling.	C. Replace timer.
	D. Foreign material in brine valve.	D. Replace brine valve seat and clean valve.
	E. Foreign material in brine line flow control.	E. Clean brine line flow control.

Troubleshooting

Problem	Cause	Correction
8. Softener fails to draw brine.	A. Drain line flow control is plugged.	A. Clean drain line flow control.
	B. Injector is plugged.	B. Clean injector
	C. Injector screen plugged.	C. Clean screen.
	D. Line pressure is too low.	D. Increase line pressure to 20 P.S.I.
	E. Internal control leak	E. Change seals, spacers, and piston assembly.
	F. Service adapter did not cycle.	F. Check drive motor and switches.
9. Control cycles continuously.	A. Misadjusted, broken, or shorted switch.	A. Determine if switch or timer is faulty and replace it, or replace complete power head.
10. Drain flows continuously.	A. Valve is not programming correctly.	A. Check timer program and positioning of control. Replace power head assembly if not positioning properly.
	B. Foreign material in control.	B. Remove power head assembly and inspect bore. Remove foreign material and check control in various regeneration positions.
	C. Internal control leak.	C. Replace seals and piston assembly.

General Service Hints For Meter Control

Problem: Softener delivers hard water

Reason: Reserve capacity has been exceeded.

Correction: Check salt dosage requirements and reset program wheel to provide additional reserve.

Reason: Program wheel is not rotating with meter output.

Correction: Pull cable out of meter cover and rotate manually. Program wheel must move without binding and clutch must give positive clicks when program wheel strikes regeneration stop. If it does not, replace timer.

Reason: Meter is not measuring flow.

Correction: Check meter with meter checker.

Flow Data & Injector Draw Rates

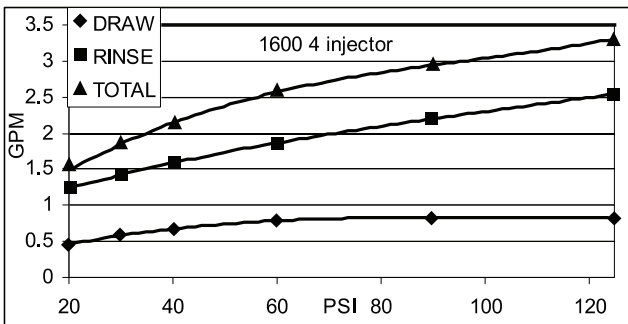
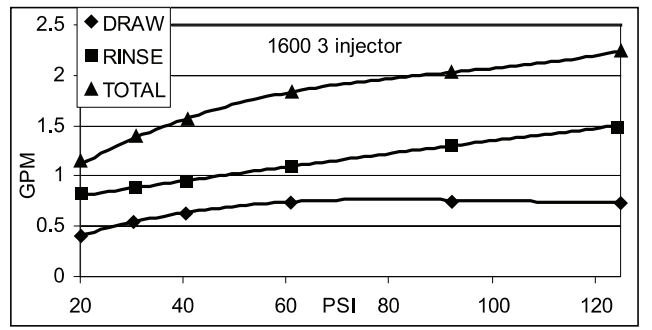
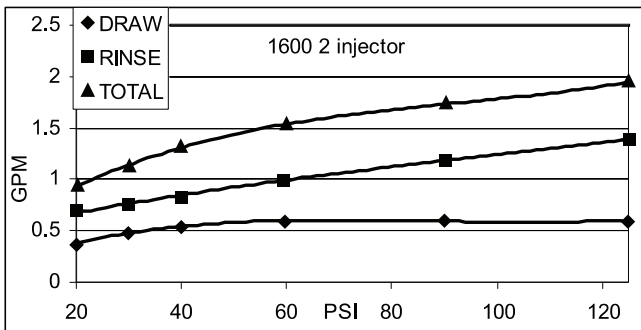
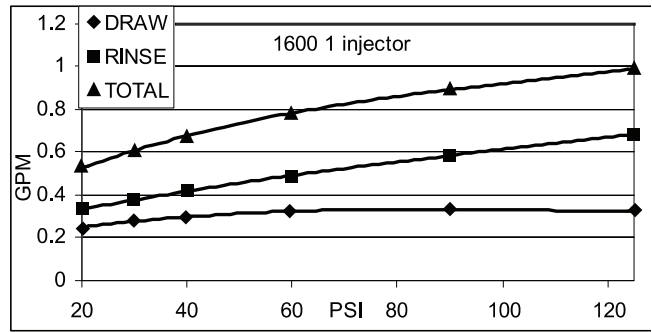
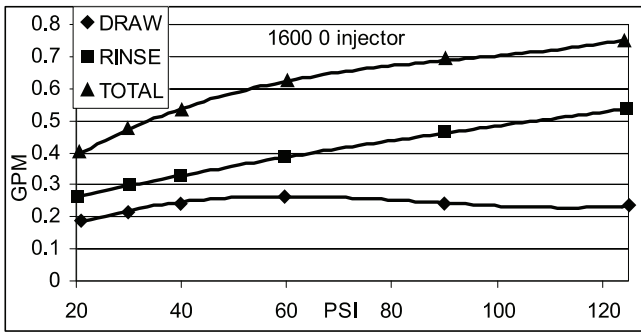

TR20391_REVA

Wiring Diagram

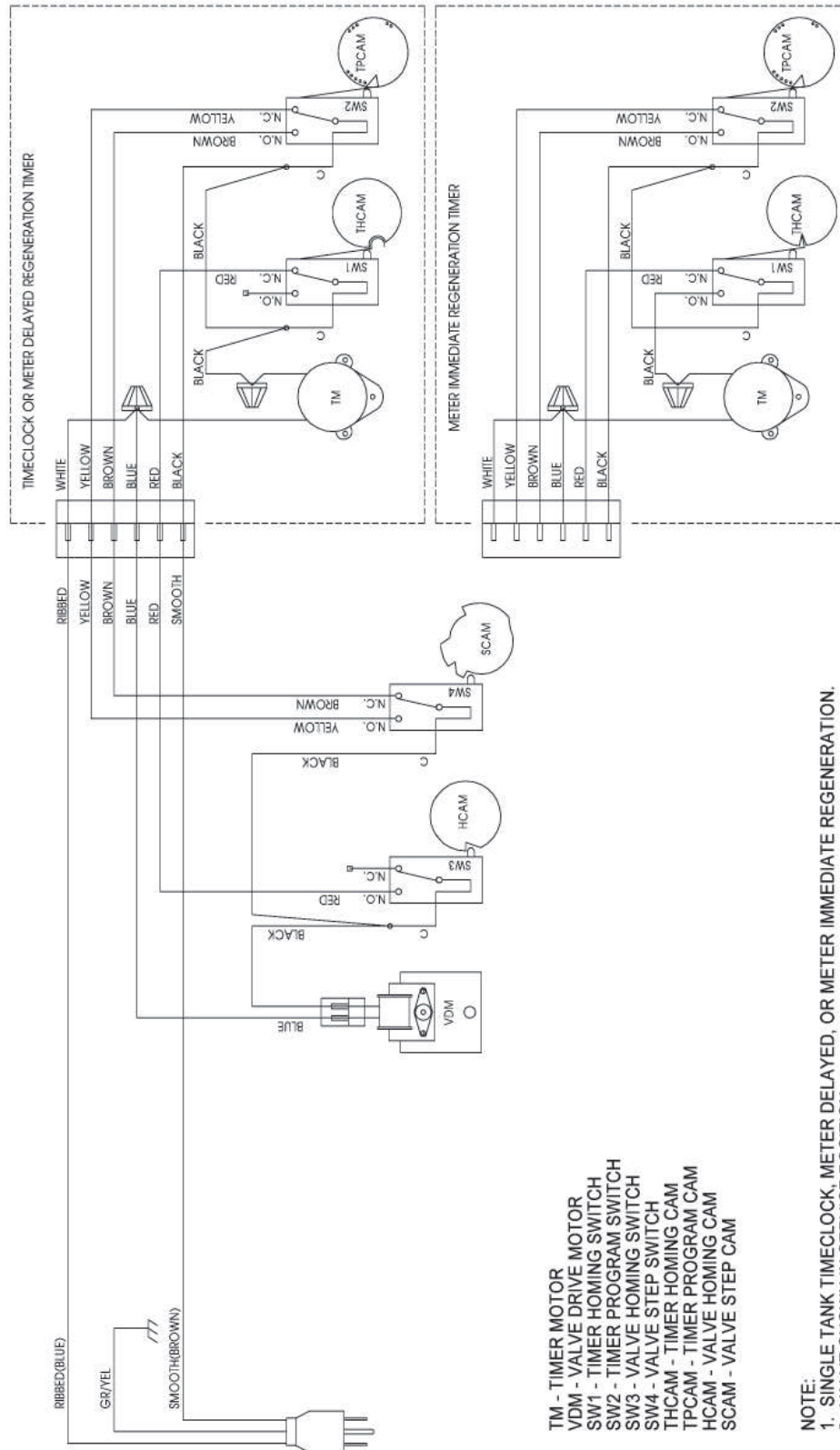

24 Hour Gear

40096-02Dial 2AM Regen Assy, Black
40096-24Dial 12AM Regen Assy, Black
60519-02Gear Assy, 3200, 24 Hour 2 Times/Day
60519-03Gear Assy, 3200, 24 Hour 3 Times/Day
60519-04Gear Assy, 3200, 24 Hour 4 Times/Day
60519-06Gear Assy, 3200, 24 Hour (12:00) 6 Times/Day

Brine Line Flow Controls (BLFC)

60010-25BLFC, 1650, .25 GPM, Plastic
60010-50BLFC, 1650, .50 GPM, Plastic
60010-100BLFC, 1650, 1.0 GPM, Plastic

Brine Valves

60011-010.....Brine Valve, 1650, Short Stem, .25 GPM, Less Tube
60011-030.....Brine Valve, 1650, Short Stem, 1.0 GPM, Less Tube

Bypasses

60049.....Bypass Plastic Assy
60040SS.....Bypass Valve, 5600, 3/4" NPT
60041SS.....Bypass Valve, 5600, 1" NPT

Cam

60160-15Drive Cam Assy, STF, Blue

Clamp

60503.....Clamp Ring Assembly, 2510

Coupling

60510.....Adapter Coupling Assy, 5600

Drain Line Flow Controls

60705-00DLFC, Plastic, Blank
60705-06DLFC, Plastic, .60 GPM
60705-08DLFC, Plastic, .80 GPM
60705-10DLFC, Plastic, 1.0 GPM
60705-12DLFC, Plastic, 1.2 GPM
60705-13DLFC, Plastic, 1.3 GPM
60705-15DLFC, Plastic, 1.5 GPM
60705-17DLFC, Plastic, 1.7 GPM
60705-20DLFC, Plastic, 2.0 GPM
60705-24DLFC, Plastic, 2.4 GPM
60705-30DLFC, Plastic, 3.0 GPM
60705-35DLFC, Plastic, 3.5 GPM
60705-40DLFC, Plastic, 4.0 GPM
60705-45DLFC, Plastic, 4.5 GPM
60705-50DLFC, Plastic, 5.0 GPM
60705-60DLFC, Plastic, 6.0 GPM
60705-70DLFC, Plastic, 7.0 GPM
60706-8.0DLFC, QC x 3/4" F, 8.0 GPM
60706-9.0DLFC, QC x 3/4" F, 9.0 GPM
60706-12DLFC, QC x 3/4" F, 12.0 GPM
60706-15DLFC, QC x 3/4" F, 15.0 GPM

Drives

60050-21Drive Assy, 2750, STF, 120V Softener

Injectors

60480-XX.....1600 Injector Assy

Meters

60088-180Meter Assy, 3/4" Dual Port, Slip Std, Rt Ang/180
.....Plastic Paddle w/clps
60089-180Meter Assy, 3/4" Dual Port, Slip Ext, Rt Ang/180
.....Plastic Paddle w/clps

Pistons

61670-00Piston Assy w/Seal&Spacer Kit 2510 Piston
61670-01Piston Assy w/Seal&Spacer Kit 2510
.....Piston NHWBP
61671-00Piston Conversion w/Seal&Spacr 2510
.....NHWBP Filter
61671-01Piston Conversion w/Seal&Spacr 2510
.....NHWBP 1600

Program Wheels

60405-10Program Wheel w/3/4" Std Label Set @ 21
60405-15Program Wheel w/3/4" Std Label
.....w/People Label Set @ 21

Safety Brine (2300)

60028-30Float Assy, 2300, 30", White
60027-FFA....Safety Brine Valve Body, 2300,
.....Fitting Facing Arm
60027-FFS....Safety Brine Valve Body,
.....Fitting Facing Stud

Sales & Service Aids

40097.....Literature, 2510, S/Manual
40729.....Literature, 2510, Spec Sheet

Skipper Wheels

14860.....Skipper Wheel Assy, 7 Day
14381.....Skipper Wheel Assy, 12 Day

Yokes

13708-40Yoke, 1", Sweat
13708-45Yoke, 3/4", Sweat
18706.....Yoke, 1", NPT, Plastic
18706-02Yoke, 3/4", NPT, Plastic
19275.....Yoke, Angle 90 Deg. 3/4", NPT
19275-45Yoke, Angle 90 Deg., 3/4 Sweat
19620-01Yoke Assy, 3/4", R/Angle, 90 Deg w/O-rings,
.....Clips, and Screws
40636.....Yoke, 1 1/4", NPT
40636-49Yoke, 1 1/4", Sweat
41026-01Yoke, 1", NPT, SS
41027-01Yoke, 3/4", NPT, Cast, Machd

Notes

Distributed By:

**APPLIED
MEMBRANES INC.®**

2325 Cousteau Ct. Vista, CA 92081 ☎ (760) 727-3711 📠 (760) 727-4427
🌐 www.appliedmembranes.com ✉ sales@appliedmembranes.com