

Model 2850

Service Manual

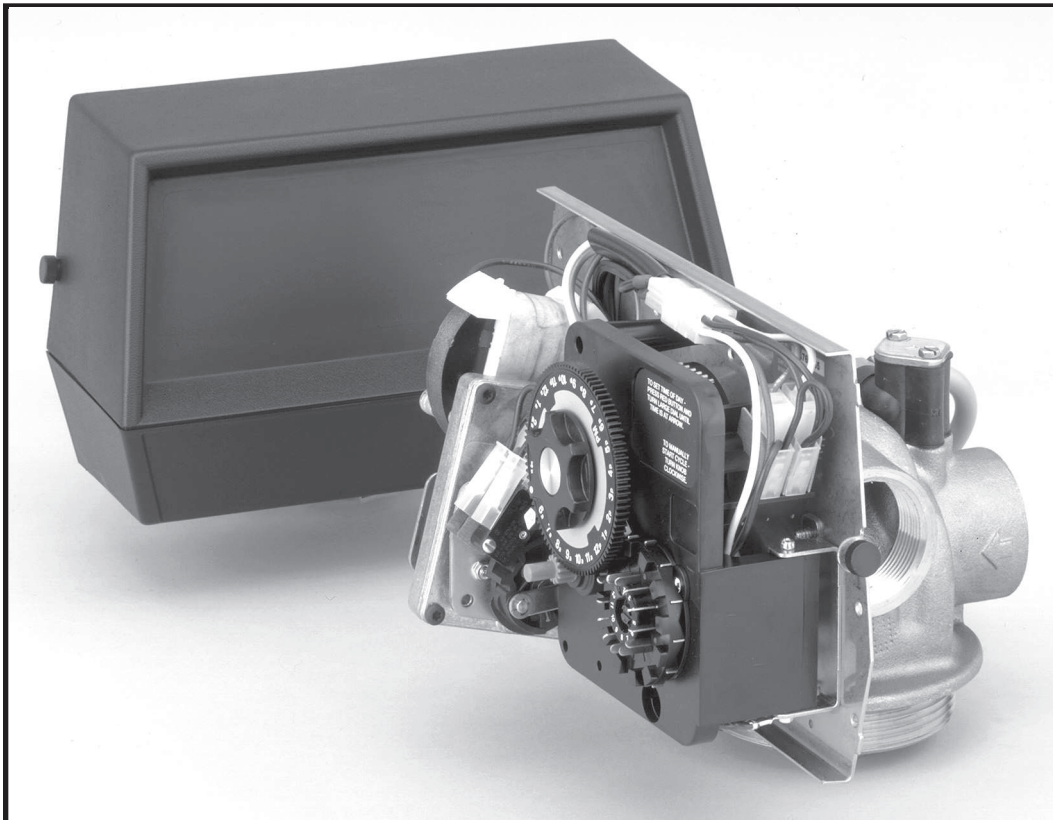

Distributed By:

**APPLIED
MEMBRANES INC.®**

IMPORTANT: Fill in Pertinent Information on Page 3 for Future Reference

2325 Cousteau Ct. Vista, CA 92081 ☎ (760) 727-3711 📠 (760) 727-4427
🌐 www.appliedmembranes.com ✉ sales@appliedmembranes.com

Table of Contents

Job Specification Sheet	3
Installation Instructions	4
Start-Up Instructions	5
3200 Timer Setting Procedure	6
3210 Timer Setting Procedure	7
3200, 3210, 3220 & 3230 Regeneration Cycle Setting Procedure	8
3200 Time Clock Timer Assembly	10
3210 Meter Delayed Timer Assembly	12
3220 Meter Immediate Timer Assembly	14
3230 Remote Start Timer Assembly	16
Control Valve with 1700 Injector Assembly	18
Powerhead Assembly (Designer)	20
Environmental Powerhead Assembly	22
Manual Powerhead Assembly	24
1600 Series Brine System	25
1650 Brine System Assembly	26
1700 Brine System Assembly	28
1710 Brine System Assembly	30
1600 Service Valve Operator Assembly (Old Style)	31
1" Meter Assembly	32
1-1/2" Meter Assembly	33
2310 Safety Brine Valve	34
2350 Safety Brine Valve	35
Seal & Spacer Tools & Replacement	36
Troubleshooting	39
General Service Hints for Meter Control	40
Water Conditioner Flow Diagrams	41
Flow Data & Injector Draw Rates	43
Dimensions	44
System #4 - Typical Single Tank Installation with Optional Meter	46
System #5 Interlock - Typical Twin Tank Installation with Optional Meter Interlock and No Hard Water Bypass	47
System #6 - Twin Series Regeneration Installation with a Remote Meter	48
System #7 - Twin Alternator Installation with a Remote Meter	49
System #4 - Single Valve Regeneration Immediate and Delayed Valve Wiring	50
System #4 - with Remote Starter Valve Wiring	51
System #5 - Interlocked Regeneration Valve Wiring	52
System #6 - Series Regeneration Valve Wiring	53
System #7 - Alternating Regeneration 230V / 3-Way Solenoid Output Valve Wiring	54
Service Assemblies	55

IMPORTANT: The information, specifications and illustrations in this manual are based on the latest information available at the time of printing. The manufacturer reserves the right to make changes at any time without notice.

Job Specification Sheet

Job Number: _____

Model Number: _____

Water Hardness: _____ ppm or gpg

Capacity Per Unit: _____

Mineral Tank Size: _____ Diameter: _____ Height: _____

Salt Setting per Regeneration: _____

1. Type of Timer:

- A. 7 Day or 12 Day B. Meter Initiated

2. Downflow: Upflow Upflow Variable

3. Meter Size:

- A. 3/4" Std Range (125 - 2,100 gallon setting)
B. 3/4" Ext Range (625 - 10,625 gallon setting)
C. 1" Std Range (310 - 5,270 gallon setting)
D. 1" Ext Range (1,150 - 26,350 gallon setting)
E. 1-1/2" Std Range (625 - 10,625 gallon setting)
F. 1-1/2" Ext Range (3,125 - 53,125 gallon setting)
G. 2" Std Range (1,250 - 21,250 gallon setting)
H. 2" Ext Range (6,250 - 106,250 gallon setting)
I. 3" Std Range (3,750 - 63,750 gallon setting)
J. 3" Ext Range (18,750 - 318,750 gallon setting)
K. Electronic _____ Pulse Count _____ Meter Size

4. System Type:

- A. System #4: 1 Tank, 1 Meter, Immediate, or Delayed Regeneration
B. System #4: Time Clock
C. System #4: Twin Tank
D. System #5: 2-5 Tanks, 2 Meters, Interlock
E. System #6: 2-5 Tanks, 1 Meter, Series Regeneration
F. System #7: 2-5 Tanks, 1 Meter, Alternating
G. System #9: Electronic Only, 2-4 Tanks, Meter per Valve, Alternating
H. System #14: Electronic Only, 2-4 Tanks, Meter per Valve. Brings units on and offline based on flow.

5. Timer Program Settings:

- A. Backwash: _____ Minutes
B. Brine and Slow Rinse: _____ Minutes
C. Rapid Rinse: _____ Minutes
D. Brine Tank Refill: _____ Minutes
E. Pause Time: _____ Minutes
F. Second Backwash: _____ Minutes

6. Drain Line Flow Control: _____ gpm

7. Brine Line Flow Controller: _____ gpm

8. Injector Size#: _____

9. Piston Type:

- A. Hard Water Bypass
B. No Hard Water Bypass

Installation Instructions

WATER PRESSURE: A minimum of 20 pounds (1.4 bar) of water pressure is required for regeneration valve to operate effectively.

ELECTRICAL FACILITIES: An uninterrupted alternating current (A/C) supply is required. Note: Other voltages are available. Please make sure your voltage supply is compatible with your unit before installation.

EXISTING PLUMBING: Condition of existing plumbing should be free from lime and iron buildup. Piping that is built up heavily with lime and/or iron should be replaced. If piping is clogged with iron, a separate iron filter unit should be installed ahead of the water softener.

LOCATION OF SOFTENER AND DRAIN: The softener should be located close to a drain to prevent air breaks and back flow.

BY-PASS VALVES: Always provide for the installation of a by-pass valve if unit is not equipped with one.

CAUTION: Water pressure is not to exceed 125 psi (8.6 bar), water temperature is not to exceed 110°F (43°C), and the unit cannot be subjected to freezing conditions.

Installation Instructions

1. Place the softener tank where you want to install the unit making sure the unit is level and on a firm base.
2. During cold weather, the installer should warm the valve to room temperature before operating.
3. All plumbing should be done in accordance with local plumbing codes. The pipe size for residential drain line should be a minimum of 1/2" (13 mm). Backwash flow rates in excess of 7 gpm (26.5 Lpm) or length in excess of 20' (6 m) require 3/4" (19 mm) drain line. Commercial drain lines should be the same size as the drain line flow control.
4. Refer to the dimensional drawing for cutting height of the distributor tube. If there is no dimensional drawing, cut the distributor tube flush with the top of the tank.
5. Lubricate the distributor O-ring seal and tank O-ring seal. Place the main control valve on tank. Note: Only use silicone lubricant.
6. Solder joints near the drain must be done prior to connecting the Drain Line Flow Control fitting (DLFC). Leave at least 6" (15 cm) between the DLFC and solder joints when soldering pipes that are connected on the DLFC. Failure to do this could cause interior damage to the DLFC.
7. Teflon tape is the only sealant to be used on the drain fitting. The drain from twin tank units may be run through a common line.
8. Make sure that the floor is clean beneath the salt storage tank and that it is level.
9. Place approximately 1" (25 mm) of water above the grid plate. If a grid is not utilized, fill to the top of the air check (Figure 1) in the salt tank. Do not add salt to the brine tank at this time.
10. On units with a by-pass, place in by-pass position. Turn on the main water supply. Open a cold soft water tap nearby and let run a few minutes or until the system is free from foreign material (usually solder) that may have resulted from the installation. Once clean, close the water tap.
11. Slowly place the by-pass in service position and let water flow into the mineral tank. When water flow stops, slowly open a cold water tap nearby and let run until the air is purged from the unit.
12. Plug unit into an electrical outlet. Note: All electrical connections must be connected according to local codes. Be certain the outlet is uninterrupted.

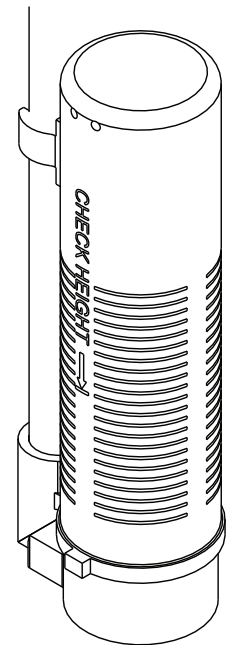

60002-34REVC

Figure 1 Residential Air Check Valve

	<p>CAUTION</p> <ul style="list-style-type: none">• Do not exceed 125 psi water pressure• Do not exceed 110°F (43°C) water temperature• Do not subject unit to freezing conditions
--	--

Start-Up Instructions

The water softener should be installed with the inlet, outlet, and drain connections made in accordance with the manufacturer's recommendations, and to meet applicable plumbing codes.

1. Turn the manual regeneration knob slowly in a clockwise direction until the program micro switch lifts on top of the first set of pins. Allow the drive motor to move the piston to the first regeneration step and stop. Each time the program switch position changes, the valve will advance to the next regeneration step. Always allow the motor to stop before moving to the next set of pins or spaces.

NOTE: For electronic valves, please refer to the manual regeneration part of the timer operation section. If the valve came with a separate electronic timer service manual, refer to the timer operation section of the electronic timer service manual.

2. Position the valve to backwash. Ensure the drain line flow remains steady for 10 minutes or until the water runs clear (see above).
3. Position the valve to the brine / slow rinse position. Ensure the unit is drawing water from the brine tank (this step may need to be repeated).
4. Position the valve to the rapid rinse position. Check the drain line flow, and run for 5 minutes or until the water runs clear.
5. Position the valve to the start of the brine tank fill cycle. Ensure water goes into the brine tank at the desired rate. The brine valve drive cam will hold the valve in this position to fill the brine tank for the first regeneration.
6. Replace control box cover.
7. Put salt in the brine tank.

NOTE: Do not use granulated or rock salt.

3200 Timer Setting Procedure

How To Set Days On Which Water Conditioner Is To Regenerate (Figure 2):

Rotate the skipper wheel until the number "1" is at the red pointer. Set the days that regeneration is to occur by sliding tabs on the skipper wheel outward to expose trip fingers. Each tab is one day. Finger at red pointer is tonight. Moving clockwise from the red pointer, extend or retract fingers to obtain the desired regeneration schedule.

How To Set The Time Of Day:

1. Press and hold the red button in to disengage the drive gear.
2. Turn the large gear until the actual time of day is at the time of day pointer.
3. Release the red button to again engage the drive gear.

How To Manually Regenerate Your Water Conditioner At Any Time:

1. Turn the manual regeneration knob clockwise.
2. This slight movement of the manual regeneration knob engages the program wheel and starts the regeneration program.
3. The black center knob will make one revolution in the following approximately three hours and stop in the position shown in the drawing.
4. Even though it takes three hours for this center knob to complete one revolution, the regeneration cycle of your unit might be set for only one half of this time.
5. In any event, conditioned water may be drawn after rinse water stops flowing from the water conditioner drain line.

How to Adjust Regeneration Time:

1. Disconnect the power source.
2. Locate the three screws behind the manual regeneration knob by pushing the red button in and rotating the 24 hour dial until each screw appears in the cut out portion of the manual regeneration knob.
3. Loosen each screw slightly to release the pressure on the time plate from the 24 hour gear.
4. Locate the regeneration time pointer on the inside of the 24 hour dial in the cut out.
5. Turn the time plate so the desired regeneration time aligns next to the raised arrow.
6. Push the red button in and rotate the 24 hour dial. Tighten each of the three screws.
7. Push the red button and locate the pointer one more time to ensure the desired regeneration time is correct.
8. Reset the time of day and restore power to the unit.

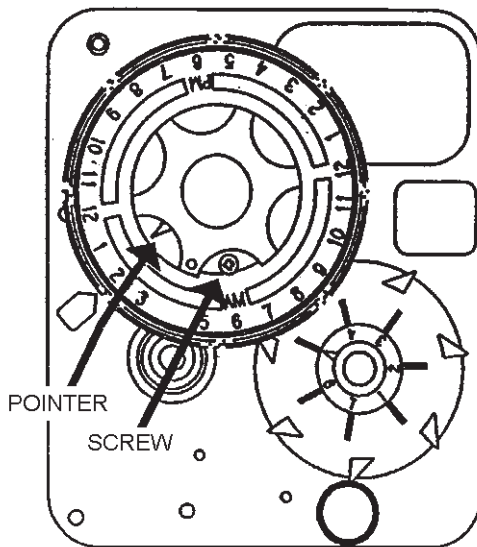
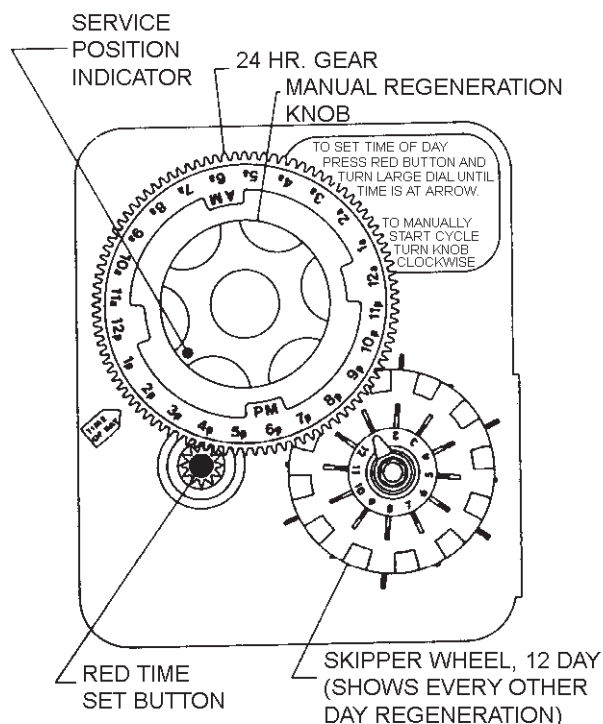

3200 ADJUSTABLE REGENERATION TIMER

IMPORTANT!
SALT LEVEL MUST ALWAYS BE ABOVE
WATER LEVEL IN BRINE TANK

61502_3200REVA

Figure 2

3210 Timer Setting Procedure

Typical Programming Procedure

Calculate the gallon capacity of the system, subtract the necessary reserve requirement and set the gallons available opposite the small white dot on the program wheel gear (Figure 3).

NOTE: Drawing shows 8,750 gallon setting. The capacity (gallons) arrow (15) shows zero gallons remaining. The unit will regenerate tonight at the set regeneration time.

How To Set The Time Of Day:

1. Press and hold the red button in to disengage the drive gear.
2. Turn the large gear until the actual time of day is opposite the time of day pointer.
3. Release the red button to again engage the drive gear.

How To Manually Regenerate Your Water Conditioner At Any Time:

1. Turn the manual regeneration knob clockwise.
2. This slight movement of the manual regeneration knob engages the program wheel and starts the regeneration program.
3. The black center knob will make one revolution in the following approximately three hours and stop in the position shown in the drawing.
4. Even though it takes three hours for this center knob to complete one revolution, the regeneration cycle of your unit might be set for only one half of this time.
5. In any event, conditioned water may be drawn after rinse water stops flowing from the water conditioner drain line.

Immediate Regeneration Timers:

These timers do not have a 24 hour gear. Setting the gallons on the program wheel and manual regeneration procedure are the same as previous instructions. The timer will regenerate as soon as the capacity gallons reaches zero.

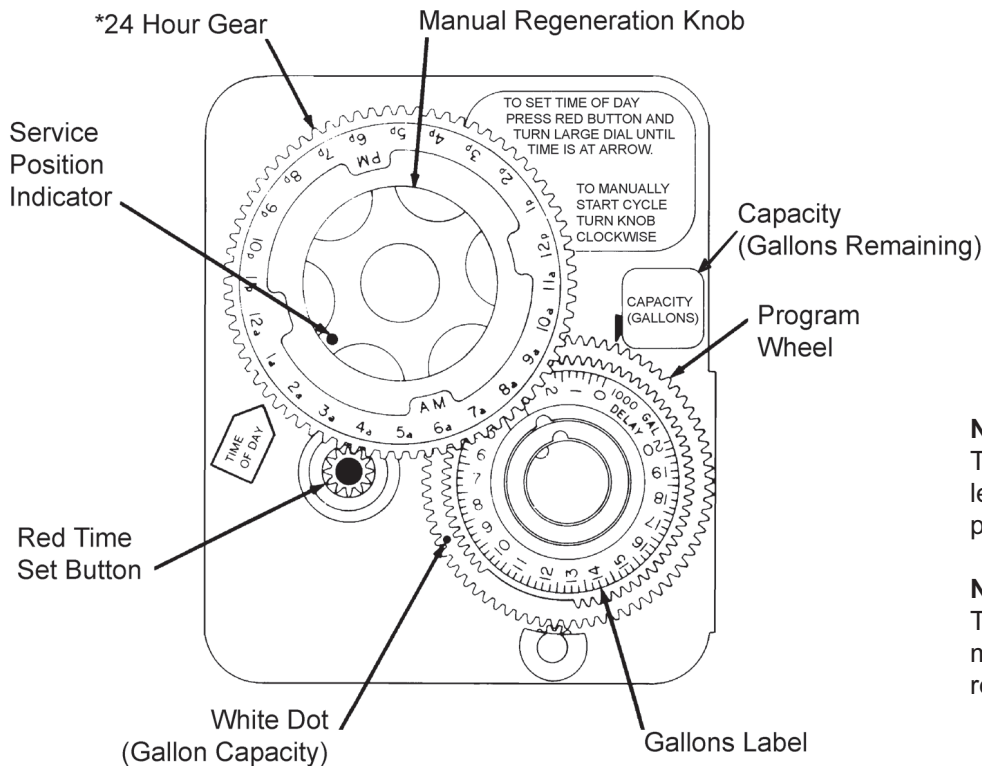

NOTE:

The program wheel to the left may be different than the program wheel on the product.

NOTE:

To set meter capacity rotate manual knob one - 360° revolution to set gallonage.

*Immediate regeneration timers do not have a 24-hour gear. No time of day can be set.

61502_3200REVA

Figure 3

3200, 3210, 3220, 3230 Regeneration Cycle Setting Procedure

How To Set The Regeneration Cycle Program:

The regeneration cycle program on your water conditioner has been factory preset, however, portions of the cycle or program may be lengthened or shortened in time to suit local conditions.

3200 Series Timers (Figure 4)

1. To expose cycle program wheel, grasp timer in upper left-hand corner and pull, releasing snap retainer and swinging timer to the right.
2. To change the regeneration cycle program, the program wheel must be removed. Grasp program wheel and squeeze protruding lugs toward center, lift program wheel off timer. Switch arms may require movement to facilitate removal.
3. Return timer to closed position engaging snap retainer in back plate. Make certain all electrical wires locate above snap retainer post.

Timer Setting Procedure

How To Change The Length Of The Backwash Time:

The program wheel as shown in the drawing is in the service position. As you look at the numbered side of the program wheel, the group of pins starting at zero determines the length of time your unit will backwash.

EXAMPLE: If there are six pins in this section, the time of backwash will be 12 min. (2 min. per pin). To change the length of backwash time, add or remove pins as required. The number of pins times two equals the backwash time in minutes.

How To Change The Length Of Brine And Rinse Time:

1. The group of holes between the last pin in the backwash section and the second group of pins determines the length of time that your unit will brine and rinse (2 min. per hole).
2. To change the length of brine and rinse time, move the rapid rinse group of pins to give more or fewer holes in the brine and rinse section. Number of holes times two equals brine and rinse time in minutes.

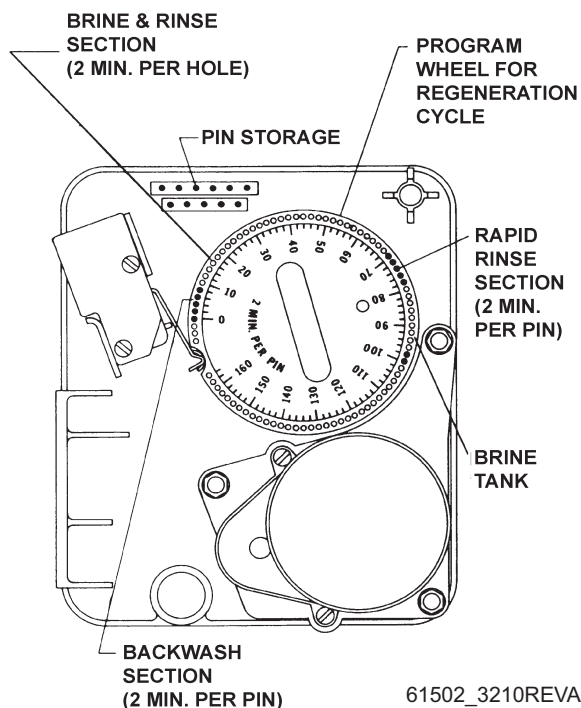

Figure 4

How To Change The Length Of Rapid Rinse:

1. The second group of pins on the program wheel determines the length of time that your water conditioner will rapid rinse (2 min. per pin).
2. To change the length of rapid rinse time, add or remove pins at the higher numbered end of this section as required. The number of pins times two equals the rapid rinse time in minutes.

How To Change The Length Of Brine Tank Refill Time:

1. The second group of holes in the program wheel determines the length of time that your water conditioner will refill the brine tank (2 min. per hole).
2. To change the length of refill time, move the two pins at the end of the second group of holes as required.
3. The regeneration cycle is complete when the outer microswitch is tripped by the two pin set at end of the brine tank refill section.
4. The program wheel, however, will continue to rotate until the inner micro switch drops into the notch on the program wheel.

3200 Time Clock Timer Assembly

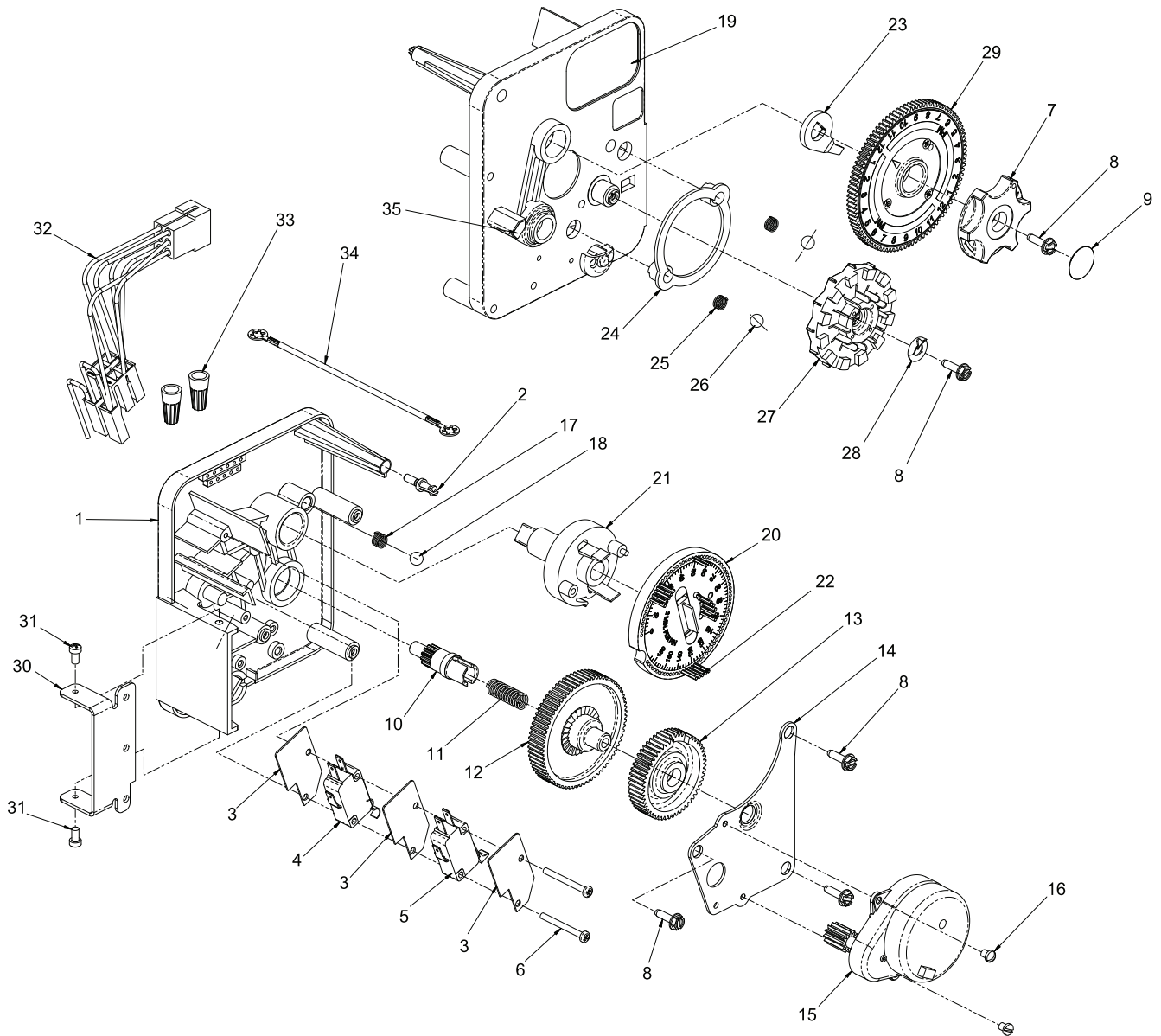

61502-3200_REVA

For Service Assembly Numbers, See the Back of this Manual

3200 Time Clock Timer Assembly

Item No.	Quantity	Part No.	Description
1	1	13870	Housing, Timer, 3200
2	1	14265	Clip, Sping
3	3	14087	Insulator
4	1	10896	Switch, Micro
5	1	15320	Switch, Micro, Timer
6	2	11413	Screw, Pan Hd Mach, 4-40 x 1-1/8
7	1	13886	Knob, 3200
8	5	13296	Screw, Hex Wsh, 6-20 x 1/2
9	1	11999	Label, Button
10	1	13018	Pinion, Idler
11	1	13312	Spring, Idler Shaft
12	1	13017	Gear, Idler
13	1	13164	Gear, Drive
14	1	13887	Plate, Motor Mounting
15	1	18743-1	Motor, 120V, 60Hz, 1/30 RPM, 5600
		19659-1	Motor, 24V, 60Hz, 1/30 RPM
16	2	13278	Screw, Slted Fillister Hd 6-32 x .156
17	1	15424	Spring, Detent, Timer
18	1	15066	Ball, 1/4", Delrin
19	1	15465	Label, Caution
20	1	19210	Program Wheel Assy
21	1	13911	Gear, Main Drive, Timer
22	17	41754	Pin, Spring, 1/16 x 5/8 SS, Timer
23	1	13011	Arm, Cycle Actuator
24	1	13864	Ring, Skipper Wheel
25	2	13311	Spring, Detent, Timer
26	2	13300	Ball, 1/4", SS
27	1	14381	Skipper Wheel Assy, 12 Day
		14860	Skipper Wheel Assy, 7 Day
28	1	13014	Pointer, Regeneration
29	1	40096-24	Dial, 12 AM Regen Assy, Black
		40096-02	Dial, 2 AM Regen Assy, Black
30	1	13881	Bracket, Hinger Timer
31	2	11384	Screw, Phil, 6-32 x 1/4 Zinc
32	1	13902	Harness, 3200
33	2	40422	Nut, Wire, Tan
34	1	15354-01	Wire, Ground, 4"
35	1	14007	Label, Time of Day

For Service Assembly Numbers, See the Back of this Manual

3210 Meter Delayed Timer Assembly

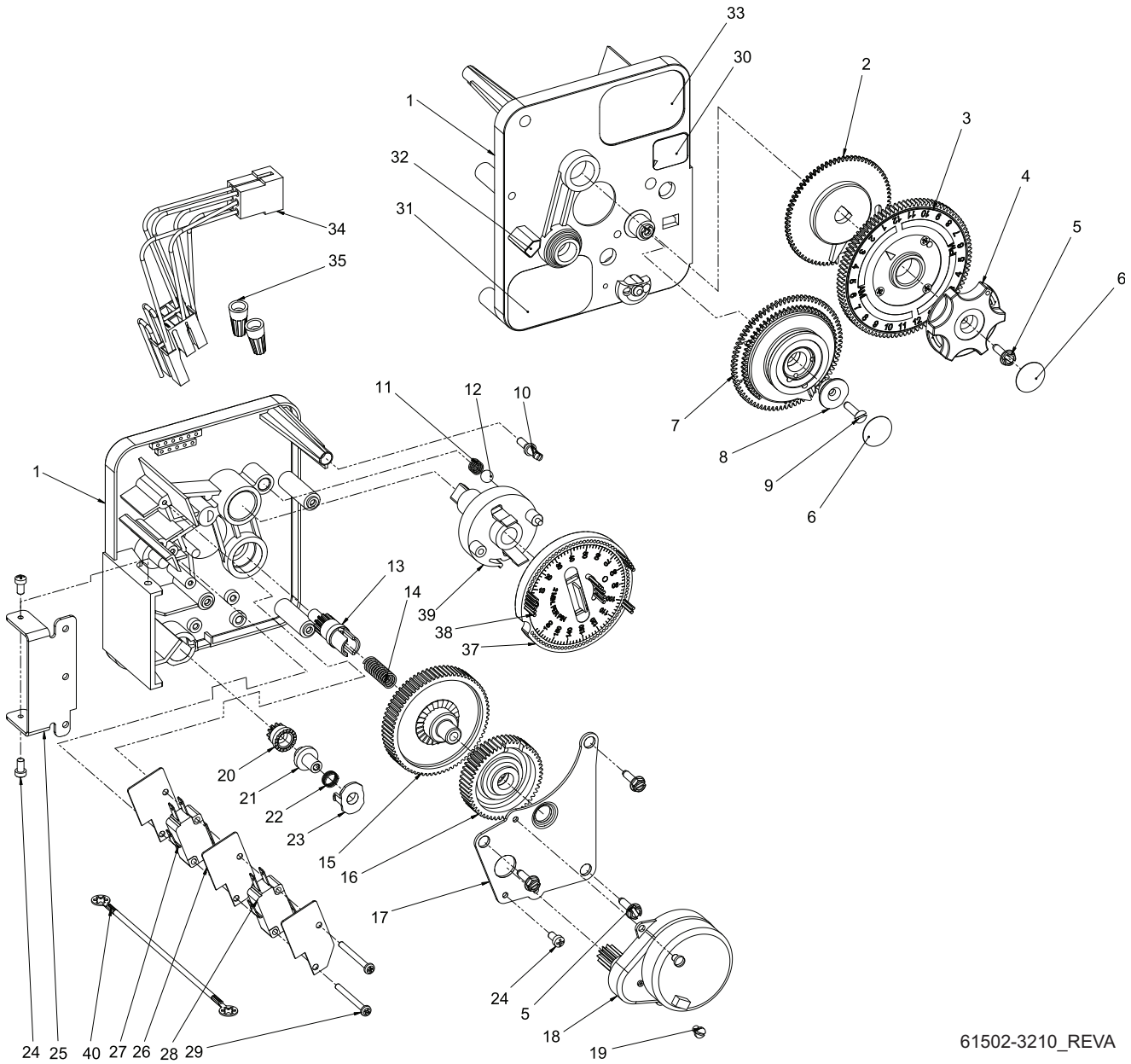

61502-3210_REVA

For Service Assembly Numbers, See the Back of this Manual

3210 Meter Delayed Timer Assembly

Item No.	Quantity	Part No.	Description
1	1	13870	Housing, Timer, 3200
2	1	13802	Gear, Cycle Actuator
3	1	40096-02	Dial 2 AM Regen Assy, Black
4	1	13886	Knob, 3200
5	4	13296	Screw, Hex Wsh, 6-20 x 1/2
6	2	11999	Label, Button
7	1	60405-20	Program Wheel, w/34" Ext Label, 1-1/2" STD Set @ 100
8	1	13806	Retainer, Program Wheel
9	1	13748	Screw, Flat Head St, 6-20 x 1/2
10	1	14265	Clip, Spring
11	1	15424	Spring, Detent, Timer
12	1	15066	Ball, 1/4" Delrin
13	1	13018	Pinion, Idler
14	1	13312	Spring, Idler Shaft
15	1	13017	Gear, Idler
16	1	13164	Gear, Drive
17	1	13887	Plate, Motor Mounting
18	1	18743-1	Motor, 120V, 60Hz 1/30 RPM, 5600
19	1	13278	Screw, Fillister Hd, 6-32 x .156
20	1	13830	Pinion, Program Wheel Drive
21	1	13831	Clutch, Drive Pinion
22	1	14276	Spring, Meter, Clutch
23	1	14253	Retainer, Clutch Spring
24	3	11384	Screw, Phil, 6-32 x 1/4
25	1	13881	Bracket, Hinge Timer
26	3	14087	Insulator
27	1	10896	Switch, Micro
28	1	15320	Switch, Micro, Timer
29	2	11413	Screw, Pan Hd Mach, 4-40 x 1 1/8
30	1	14198	Label, Indicator
31	1	15465	Label, Caution
32	1	14007	Label, Time of Day
33	1	14045	Label, Instruction
34	1	13902	Harness, 3200
35	2	40422	Nut, Wire, Tan
36	1	15354-01	Wire, Ground, 4"
37	1	19210	Program Wheel Assy
38	17	41754	Pin, Spring, 1/16 x 5/8 SS, Timer
39	1	13911	Gear, Main Drive, Timer

For Service Assembly Numbers, See the Back of this Manual

3220 Meter Immediate Timer Assembly

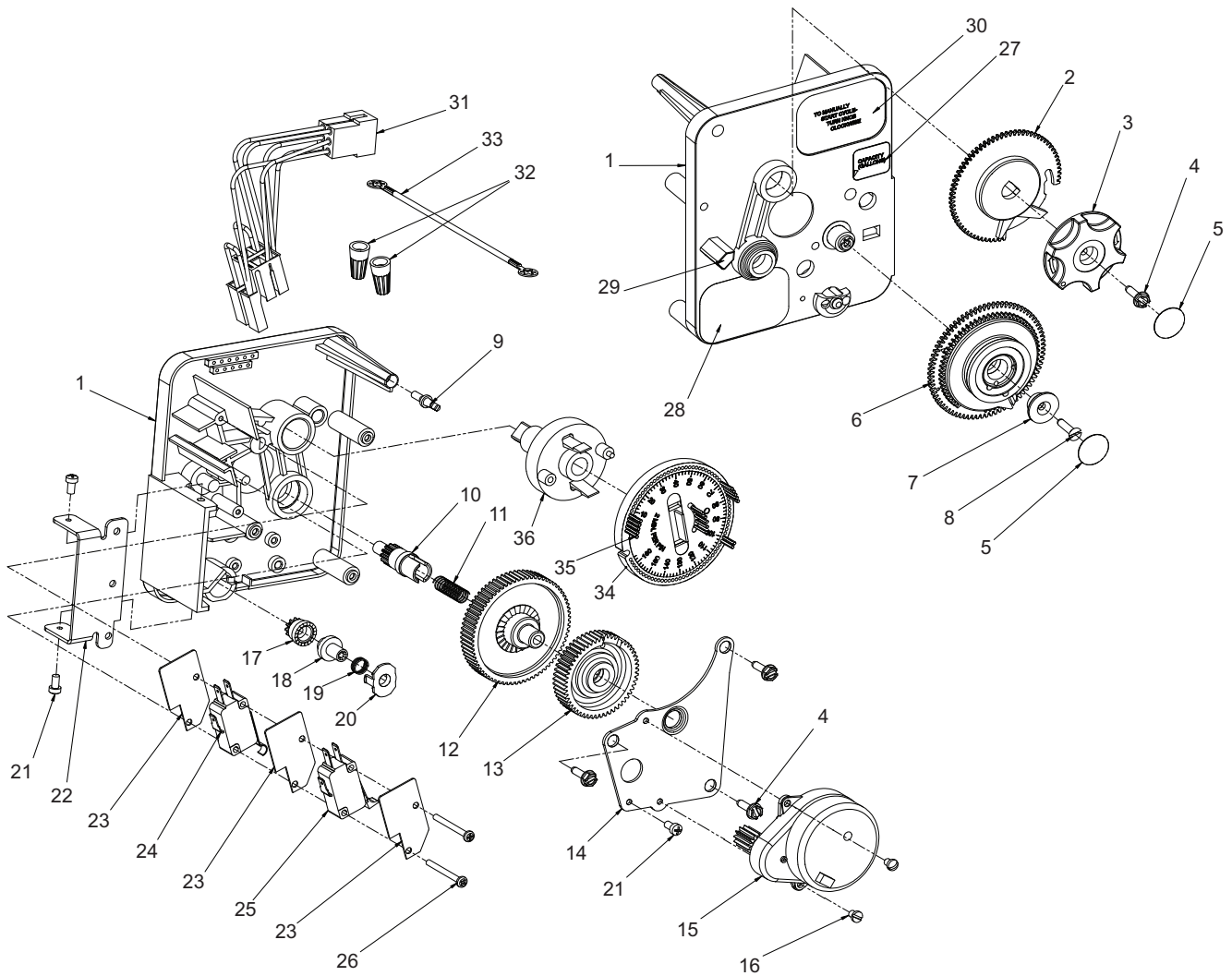

For Service Assembly Numbers, See the Back of this Manual

3220 Meter Immediate Timer Assembly

Item No.	Quantity	Part No.	Description
1	1	13870	Housing, Timer
2	1	15431	Gear, Cycle Actuator, System #5
3	1	13886	Knob, 3200
4	4	13296	Screw, Hex Wsh, 6-20 x 1/2
5	2	11999	Label, Button
6	1	60408-50	Program Wheel, W/2" Std Label
7	1	13806	Retainer, Program Wheel
8	1	13748	Screw, Flt Hd St, 6-20 x 1/2
9	1	14265	Spring Clip
10	1	13018	Pinion, Idler
11	1	18563	Idler Shaft Spring
12	1	13017	Gear, Idler
13	1	13164	Drive Gear
14	1	13887	Plate, Motor Mounting
15	1	18743-1	Motor, 120V, 60 Hz, 1/30 rpm, 5600
16	2	13278	Screw, Sltd Fillister Hd
17	1	14502	Pinion, Program Wheel
18	1	14501	Clutch, Drive Pinion
19	1	14276	Meter Clutch Spring
20	1	14253	Retainer, Clutch Spring
21	3	11384	Screw, Phil, 6-32 x 1/4 Zinc
22	1	13881	Bracket, Hinge Timer
23	3	14087	Insulator
24	1	15414-00	Micro Switch
25	1	15320	Switch, Micro, Timer
26	2	11413	Screw, Pan Hd Mach, 4-40 x 1-1/8
27	1	14198	Label, Indicator
28	1	15465	Label, Caution
29	1	14007	Label, Time of Day
30	1	15148	Label, Instruction
31	1	40617	Harness, 3220
32	2	40422	Nut, Wire, Tan
33	1	15354-01	Wire, Ground, 4"
34	1	19210-05	Program Wheel Assembly, 9000/3230
35	17	41754	Pin, Spring, 1/16 x 5/8 Stainless Steel, Timer
36	1	15055	Gear, Main Drive

For Service Assembly Numbers, See the Back of this Manual

3230 Remote Start Timer Assembly

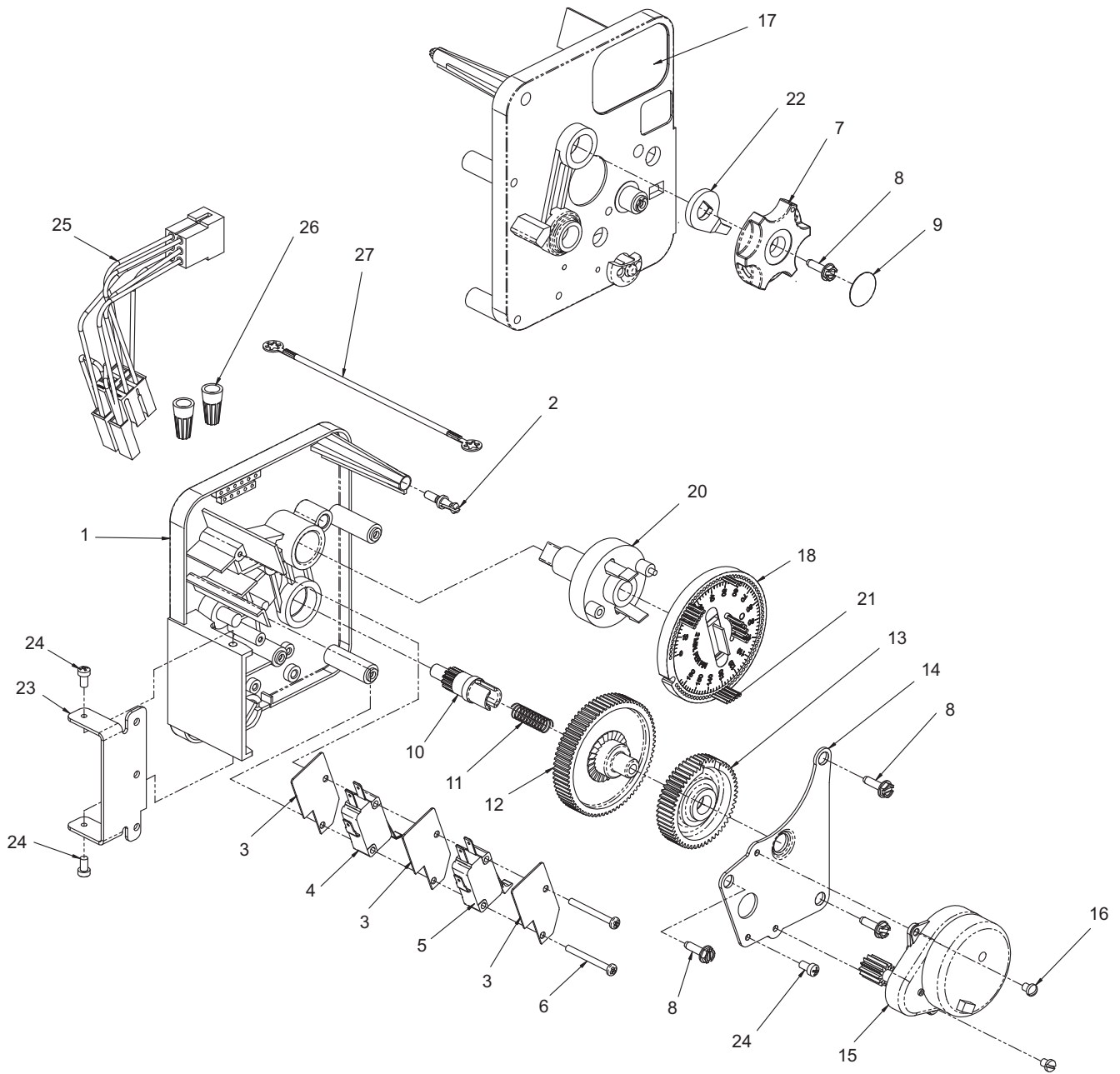

For Service Assembly Numbers, See the Back of this Manual

3230 Remote Start Timer Assembly

Item No.	Quantity	Part No.	Description
1.....	1	13870.....	Housing, Timer
2.....	1	14265.....	Spring Clip
3.....	3	14087.....	Insulator
4.....	1	15314.....	Micro Switch
5.....	1	15320.....	Switch, Micro, Timer
6.....	2	11413.....	Screw, Pan Hd Mach, 4-40 x 1-1/8
7.....	1	13886.....	Knob, 3200
8.....	4	13296.....	Screw, Hex Wsh, 6-20 x 1/2
9.....	1	11999.....	Label, Button
10.....	1	13018.....	Pinion, Idler
11.....	1	18563.....	Idler Shaft Spring
12.....	1	13017.....	Gear, Idler
13.....	1	15055.....	Drive Gear
14.....	1	13887.....	Plate, Motor Mounting
15.....	1	18743-1	Motor, 120V, 60 Hz, 1/30 rpm
.....	1	19659-1	Motor, 24V, 60 Hz 1/30 rpm
16.....	2	13278.....	Screw, Slted Fillister Hd
17.....	1	15313.....	Label, Caution
18.....	1	19210-05	Program Wheel Assembly, 3200
20.....	1	15055.....	Main Drive Gear
21.....	17	41754.....	Pin, Spring, 1/16 x 5/8 Stainless Steel, Timer
22.....	1	13011.....	Cycle Actuator Arm
23.....	1	13881.....	Bracket, Hinge Timer
24.....	3	11384.....	Screw, Phil, 6-32 x 1/4 Zinc
25.....	1	16336.....	Harness, 3230R
26.....	2	40422.....	Nut, Wire, Tan
27.....	1	15354-01	Wire, Ground, 4"

For Service Assembly Numbers, See the Back of this Manual

Control Valve with 1700 Injector Assembly

Item No.	Quantity	Part No.	Description
1.....	1.....	16250-01.....	Valve Body, 2850, Machd
2.....	6.....	16101.....	Seal, 2850
3.....	5.....	16638.....	Spacer, 9500/2850
4.....	1.....	16092.....	Piston, 2850
5.....	1.....	16436.....	Piston, 2850
6.....	1.....	16395.....	End Plug Assy, 2850
		16395-01.....	End Plug Assy, 2850, Hot Water
7.....	1.....	14805.....	Gasket, Injector Body, 1600/1700
8.....	1.....	16455.....	O-ring, -347
*9.....	1.....	13577.....	O-ring, -226
10.....	1.....	19606.....	Piston, 2850, NHWBP
11.....	1.....	19300.....	Rod, Piston, 2850
12.....	1.....	10909.....	Pin, Link
13.....	1.....	19339.....	Spacer, 2850, NHWBP
14.....	2.....	13386.....	Screw, Hex Hd Mach, 1/4 - 20x1
15.....	1.....	16395-02.....	End Plug Assy/2850, NHWBP
16.....	1.....	19298-01.....	Piston Assy, 2850, NHWBP, O-ring
Not Shown ...	1.....	60366-xx.....	DLFC 1" NPT (not shown) - specify size
Not Shown ...	1.....	17996.....	Dispenser, Air, Injector
Not Shown ...	1.....	19608-15.....	Dispenser, Commercial 1 1/2" 2850/2900/9500

Optional Side Mount:

17.....	1.....	40316.....	Adapter, Sidemount
18.....	1.....	40368.....	O-ring, -160, Sidemount, Flange
19.....	1.....	40372.....	O-ring, -142
20.....	1.....	40310.....	Base, 2850/2900/3930, Rotating
21.....	7.....	19768.....	Screw, Hex Hd, 3/8-16x1, Cap 18-8
22.....	7.....	40375.....	Washer, Flat, 3/8, Type A, N-SERS

*** Do not use O-ring if control is side mounted.**

For Service Assembly Numbers, See the Back of this Manual

Powerhead Assembly (Designer)

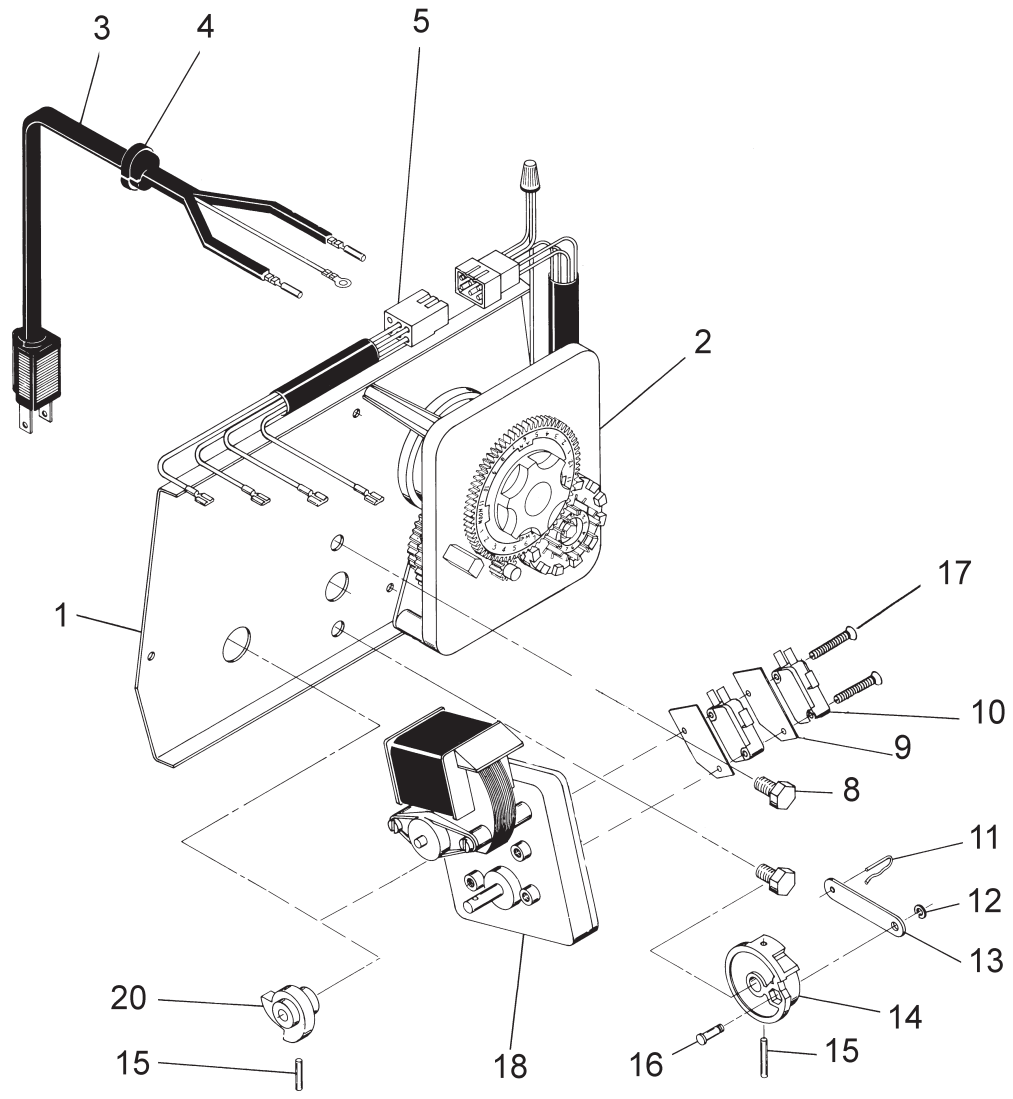

61502_2510REVB

**Motor drawing may not resemble actual.
For Service Assembly Numbers, See the Back of this Manual**

Powerhead Assembly (Designer)

Item No.	Quantity	Part No.	Description
1	1	40264	Backplate, SS/Service Valve Operator, W-T-Screws
2	1		3200, Timer 7 or 12 Day
3	1	11838	Power Cord
4	1	13547	Strain Relief
5	1	40400	Harness, Drive, Designer/Environmental
8	2	10231	Screw - Drive Mounting
9	2	10302	Insulator
10	2	10218	Switch
11	1	10909	Connecting Link Pin
12	1	10250	Retaining Ring
13	1	10621	Connecting Link
14	1	60160-15	Drive Cam Assy, STF, Blue, includes Items 11, 12, 13, 14
15	2	10338	Roll Pin
16	1	13366	Drive Bearing
17	2	14923	Screw - Switch Mounting
18	1	41543*	Motor, Drive, 115V, 50/60Hz
		42579**	Motor, Drive, 24VAC/VDC, 50/60Hz
		41545*	Motor, Drive, 230V, 50/60Hz
20	1	12777	Brine Valve Cam - Separate Time Fill (Black)

Not Shown:

	2	10300	Screw - Timer Mounting
	1	13741	Hole Plug
	1	17904	Hole Plug
	2	19367	Screw, Thumb
	1	17470	Cable Guide Assy, 3/4"
	1	17741	Meter Cable, 16.5"
	1	60232-110	Cover, Designer, 1 Pc. Black

* Bracket is integrated into the motor.

** Bracket is integrated into the motor and picture may not reflect actual component.

**Motor drawing may not resemble actual.
For Service Assembly Numbers, See the Back of this Manual**

Environmental Powerhead Assembly

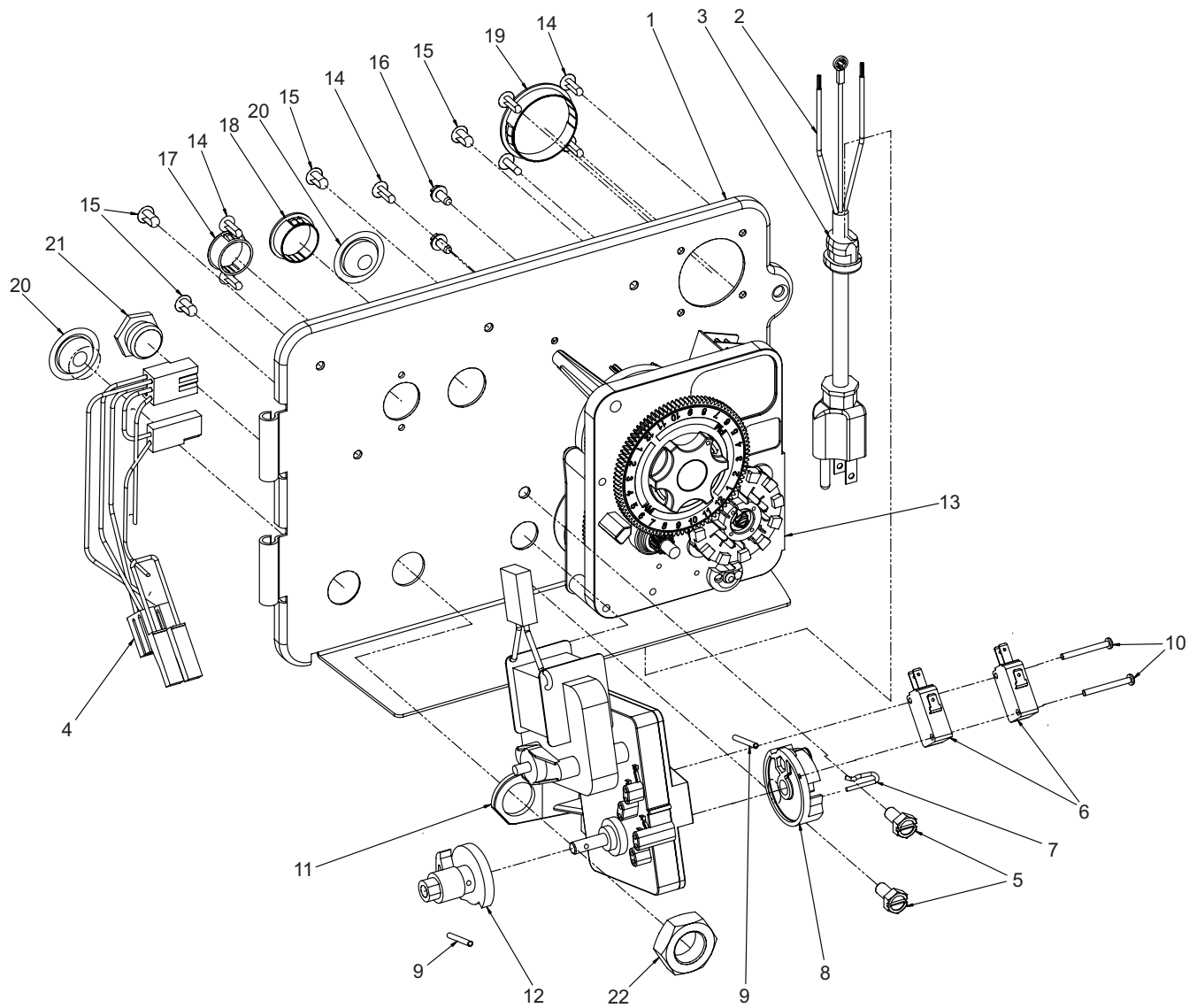

61501-2850 REV B

For Service Assembly Numbers, See the Back of this Manual

Environmental Powerhead Assembly Parts List

Item No.	Quantity	Part No.	Description
1.....	1.....	18697-13.....	Backplate, Hinged
2.....	1.....	11838.....	Power Cord, 6' Fleck
3.....	1.....	13547.....	Strain Relief, Cord
4.....	1.....	40400.....	Harness, Drive, Designer/Enviromental
5.....	2.....	10231.....	Scrw, Slot Hex, 1/4-20 x 1/2
6.....	2.....	10218.....	Switch, Micro
7.....	1.....	10909.....	Pin, Connecting Rod Spring
8.....	1.....	60160-15.....	Drive Cam Assy, STF, Blue, 2900
9.....	2.....	10338.....	Pin, Roll, 3/32 x 7/8
10.....	2.....	14923.....	Screw, Pan HD Mach, 4-40 x 1
11.....	1.....	41543.....	Motor, Drive, 115V/60HZ
12.....	1.....	12777.....	Cam, Shut-off Valve
13.....	1.....	61502-3200.....	Timer Assy, 3200 Clock
14.....	7.....	19800.....	Plug (Hole Size: Dia .140)
15.....	4.....	19801.....	Plug, Dia .190
16.....	2.....	10300.....	Screw, Hx Wash Head, 8 x 3/8
17.....	1.....	15806.....	Hole Plug, Heyco
18.....	1.....	16493.....	Plug, Hole, Heyco, .88 Dia
19.....	1.....	40306.....	Plug, 1.50 Hole, Dome, Heyco
20.....	2.....	19691.....	Plug, .750 Dia. Hole, Flush
21.....	1.....	10712.....	Fitting, Brine Valve
22.....	1.....	10269.....	Nut, Jam, 3/4-16

For Service Assembly Numbers, See the Back of this Manual

Manual Powerhead Assembly

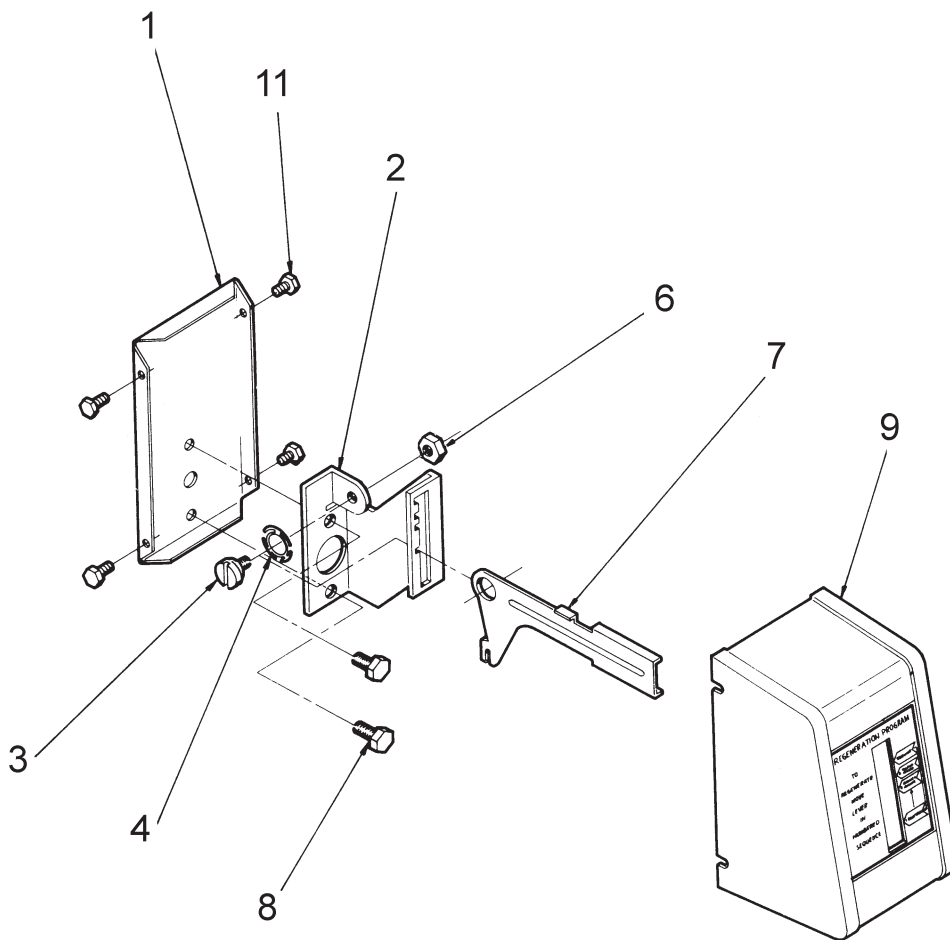

60409REVA

Item No.	Quantity	Part No.	Description
1	1	12593	Backplate, Manual
2	1	12592	Bracket, Lever Position
3	1	12596	Screw, Spec Mach, 1/4 - 20 x 1/2
4	1	12707	Washer, Spring
6	1	11235	Nut, Hex, 1/4 - 20, Mach Screw, Zinc
7	1	12594	Lever, Valve Position
8	2	10231	Screw, Slot Hex, 1/4 - 20 x 1/2 18-8 SS
9	1	60224-32	Cover Assy, Manual, Filter
	1	60224-33	Cover Assy, Manual, Softener
11	4	10300	Screw, Slot Hex Wsh, 8-18 x 3/8 Type "B" RC44-47

Not Shown:

	1	10909	Pin, Link
--	---	-------	-----------

For Service Assembly Numbers, See the Back of this Manual

1600 Series Brine System

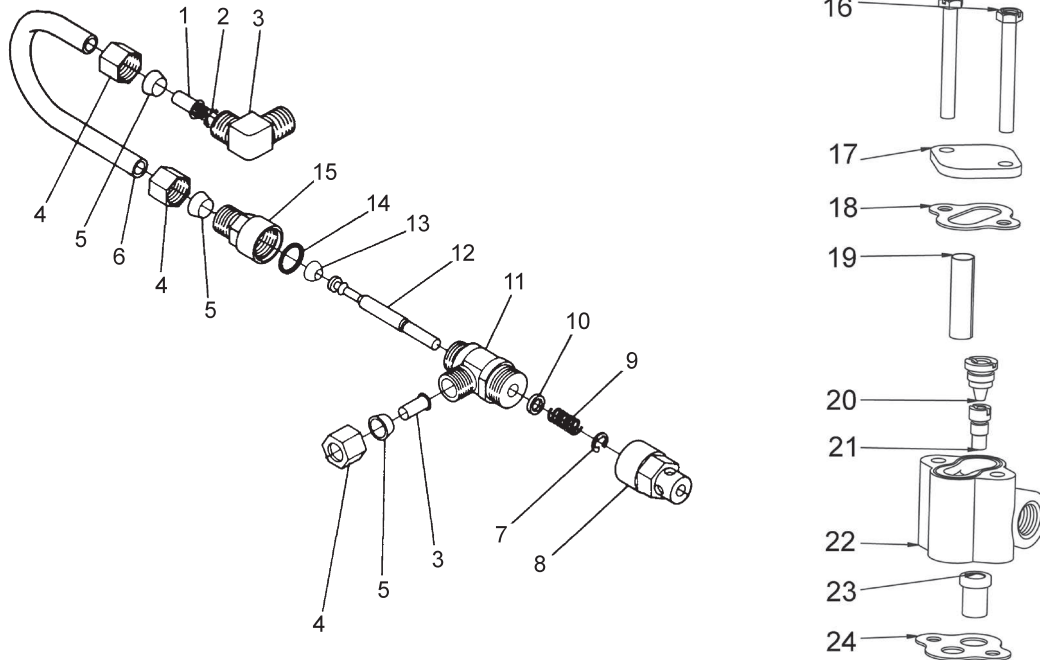

Item No.	Quantity	Part No.	Description
1	2	10332	Fitting, Insert, 3/8
2	1	12767	Screen, Brine
3	1	10328	Fitting, Elbow, 90 Deg. 1/4 PT x 3/8 Tube
4	3	10329	Fitting, Tube, 3/8 Nut, Brass
5	3	10330	Fitting, Sleeve, 3/8 Celcon
6	1	16508	Tube, Brine, 1600, PVC
	1	16508-01	Tube, Brine Valve, 2850/2900s
	1	12774	Tube, Brine Valve, 1500
	1	40027	Tube, Brine Valve, 2510
	1	15221	Tube, Brine Valve, 2750/2900
	1	42184	Tube, Brine Valve, 2850s
	1	41683*	Tube, Brine Valve, UF, 1600/1650
7	1	10250	Ring, Retaining
8	1	11749	Guide, Brine Valve Stem
9	1	10249	Spring, Brine Valve
10	1	12550	Quad Ring, -009
11	1	12748	Brine Valve Body Assy, 1600 w/Quad Ring
12	1	12552-02	Brine Valve Stem, 1600, with seat
13	1	12626	Seat, Brine Valve
14	1	11982	O-ring, -016
15	1	60020-25	BLFC, .25 GPM, 1600
	1	60020-50	BLFC, .50 GPM, 1600
	1	60020-100	BLFC, 1.0 GPM, 1600
16	2	10692	Screw, Slot Hex Hd, 10 - 24X 18-8 Stainless Steel
17	1	11893	Cap, Injector, SS
18	1	10229	Gasket, Injector Cap, 1600
19	1	10227	Screen, Injector
20	1	10913-xx	Nozzle, Injector, -xx is for injector size
21	1	10914-xx	Throat, Injector, -xx is for injector size
22	1	17776	Body, Injector, 1600
	1	17776-02*	Body, Injector, 1600 Upflow
23	1	16221	Disperser, Air
24	1	14805	Gasket, Injector Body, 1600/1700

60029

*Upflow Only

1650 Brine System Assembly

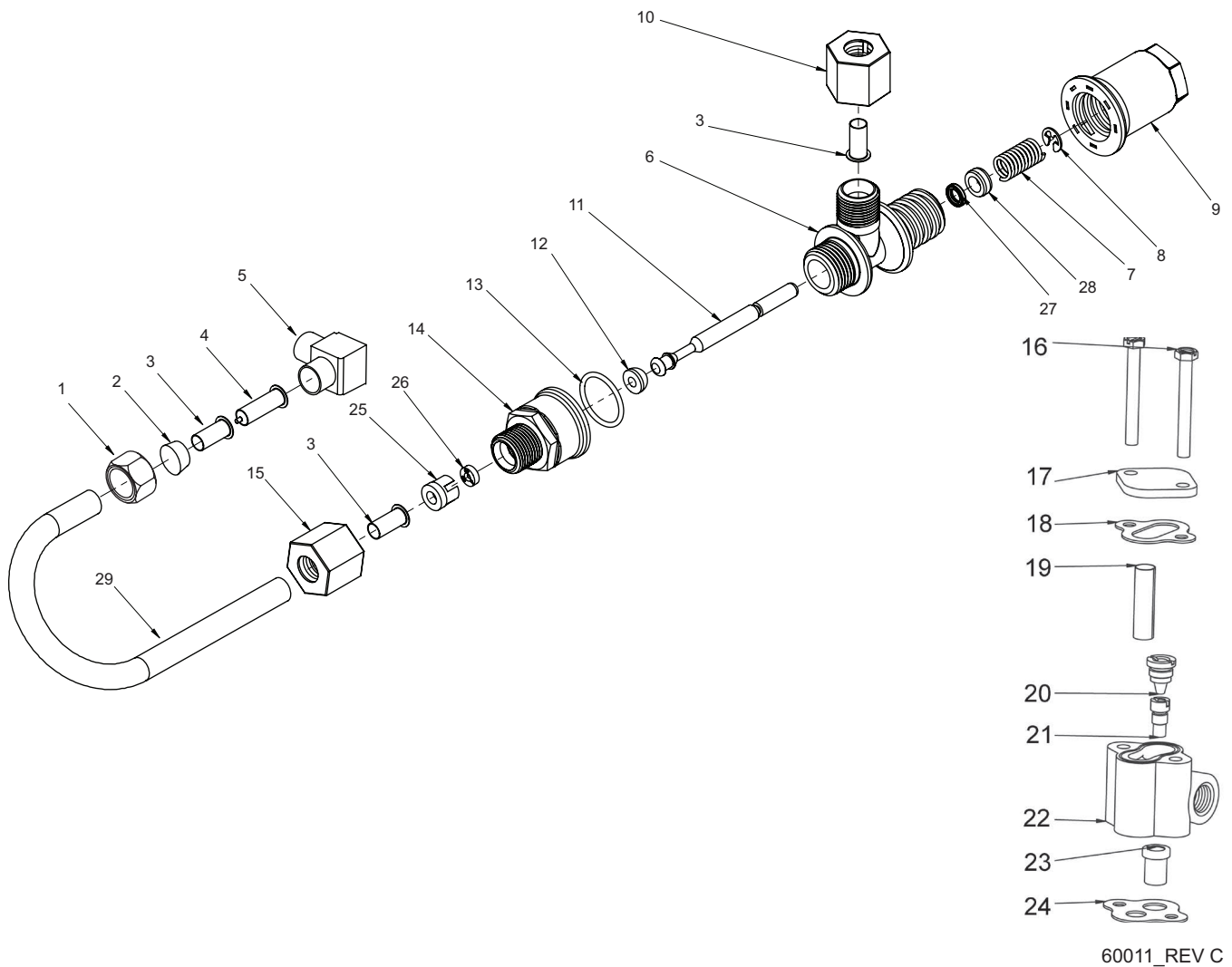

For Service Assembly Numbers, See the Back of this Manual

1650 Brine System Assembly

Item No.	Quantity	Part No.	Description
1	1	10329	Fitting, Tube, 3/8 Nut, Brass
2	1	10330	Fitting, Sleeve, 3/8 Celcon
3	3	10332	Fitting, Insert, 3/8
4	1	12767	Screen, Brine
5	1	10328	Fitting, Elbow, 90 Deg 1/4 NPT x 3/8T
6	1	17884	Brine Valve Body Assy, 1650
7	1	10249	Spring, Brine Valve
8	1	10250	Ring, Retaining
9	1	17906	Guide, Brine Valve Stem
10	1	19625	Nut Assy, 3/8", Plastic
11	1	12552-02	Brine Valve Stem, 1600
12	1	12626	Seat, Brine Valve
13	1	16924	O-ring, -018
14	1	60010-25	BLFC, 1650, .25 GPM, Plastic
	1	60010-50	BLFC, 1650, .50 GPM, Plastic
	1	60010-100	BLFC, 1650, 1.0 GPM, Plastic
15	1	19625	Nut Assy, 3/8", Plastic
16	2	10692	Screw, Slot Hex Hd, 10 - 24X 18-8 Stainless Steel
17	1	11893	Cap, Injector, Stainless Steel
18	1	10229	Gasket, Injector Cap, 1600
19	1	10227	Screen, Injector
20	1	10913-xx	Nozzle, Injector, -xx is for injector size
21	1	10914-xx	Throat, Injector, -xx is for injector size
22	1	17776	Body, Injector, 1600
	1	17776-02*	Body, Injector, 1600 Upflow
23	1	16221	Disperser, Air
24	1	14805	Gasket, Injector Body, 1600/1700
25	1	12098	Retainer, Flow Control
26	1	12095	Washer, Flow Control .50 GPM
	1	12094	Washer, Flow Control .25 GPM
	1	12097	Washer, Flow Control 1.0 GPM
27	1	12550	Quad Ring -009
	1	12550-01	Quad Ring -009 560CD
28	1	17908	Sleeve, Brine Valve Stem
29	1	16508-01	Tube, Brine Valve, 2850/1600
	1	40027	Tube, Brine Valve, 2510
	1	42184	Tube, Brine Valve, 2850s
	1	12774	Tube, Brine Valve, 1500
	1	15221	Tube, Brine Valve, 2750
	1	41683*	Tube, Brine Valve, UF, 1600/1650

*Upflow Only

For Service Assembly Numbers, See the Back of this Manual

1700 Brine System Assembly

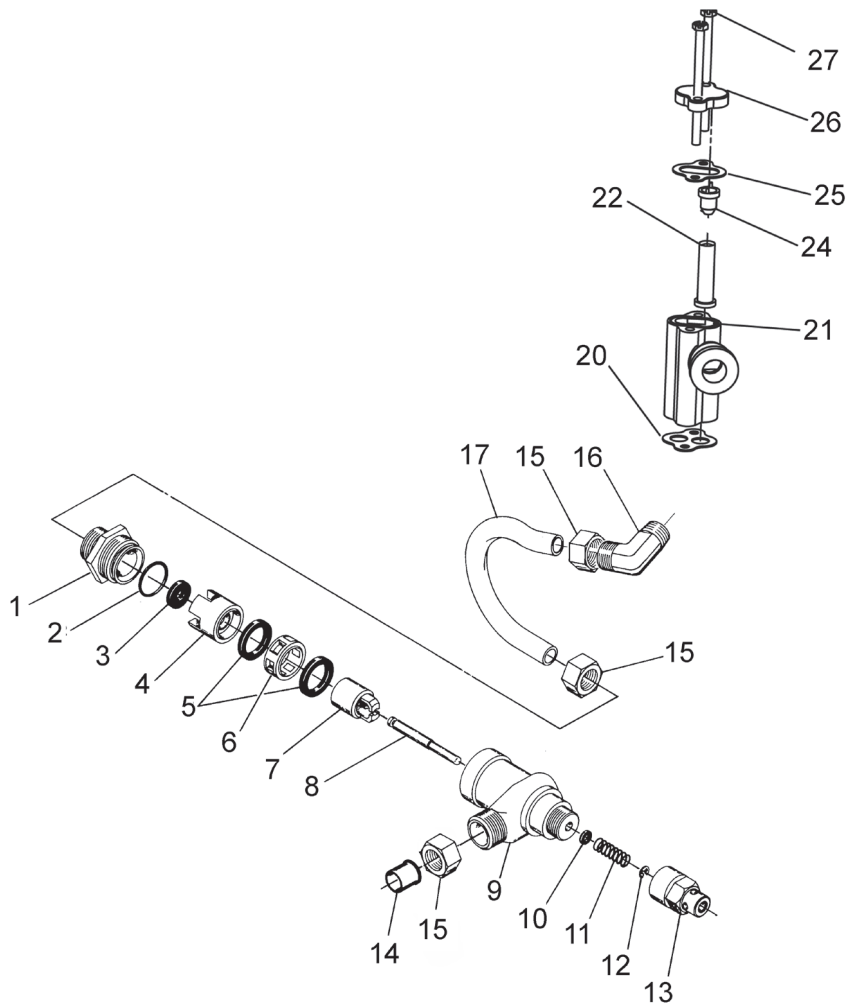

60034_REVB

For Service Assembly Numbers, See the Back of this Manual

1700 Brine System Assembly

Item No.	Quantity	Part No.	Description
1	1	14792	Plug, End, Brine Valve
2	1	13201	Quad Ring, -020
3	1	12085	Washer, Flow, 1.2 GPM
	1	12086	Washer, Flow, 1.5 GPM
	1	12087	Washer, Flow, 2.0 GPM
	1	12088	Washer, Flow, 2.4 GPM
	1	12089	Washer, Flow, 3.0 GPM
	1	12090	Washer, Flow, 3.5 GPM
	1	12091	Washer, Flow, 4.0 GPM
	1	12092	Washer, Flow, 5.0 GPM
4	1	14785	Retainer, Flow Control
5	3	14811	O-ring, -210, 560CD, Brine
6	1	14798	Spacer, 1700, Brine
7	1	14795	Piston, Brine Valve
8	1	14797	Brine Valve Stem
9	1	14790	Brine Valve Body
10	1	12550	Quad Ring, -009
11	1	15310	Spring, Brine Valve
12	1	10250	Retaining Ring
13	1	15517	Guide, Stem
14	1	15415	Fitting, Insert, 1/2", Tube
15	3	15414	Nut, 2900, w/Sleeve
16	1	15413	Fitting, Elbow, Male, 1/2T x 3/8 NPT
17	1	15416	Tube, Brine, 2900/2750
	1	16460	Tube, Brine, 2850/2900s
	1	41447*	Tube, Brine, 2900s, U/F
	1	42183	Tube, Brine, 1700, 2850s
20	1	14805	Gasket, Injector Body 1600/1700
21	1	17777	Body, Injector, 1700
	1	17777-02*	Body, Injector, 1700 U/F
22	1	14802-xxc	Throat, Injector, -xxc is for Injector Size
24		14801-xxc	Nozzle, Injection, -xxc is for Injector Size
25	1	10229	Gasket, Injector Cap, 1600
26	1	11893	Cap, Injector, Stainless Steel
	1	10228	Cap, Injector
27	2	14804	Screw, Hex Hd Mach, 10 - 24 x 2-3/4" 18-8 Stainless Steel

Not Shown:

.....	1	16974	Fitting, Plastic, Female, 3/4 x 3/4 Slip
.....	1	17996	Disperser, Air, Injector

*Upflow Only

NOTE: Item number 26 (11893) is used on injector sizes 2 through 5C. Part number 10228 is used on injector sizes 6C.

For Service Assembly Numbers, See the Back of this Manual

1710 Brine System Assembly

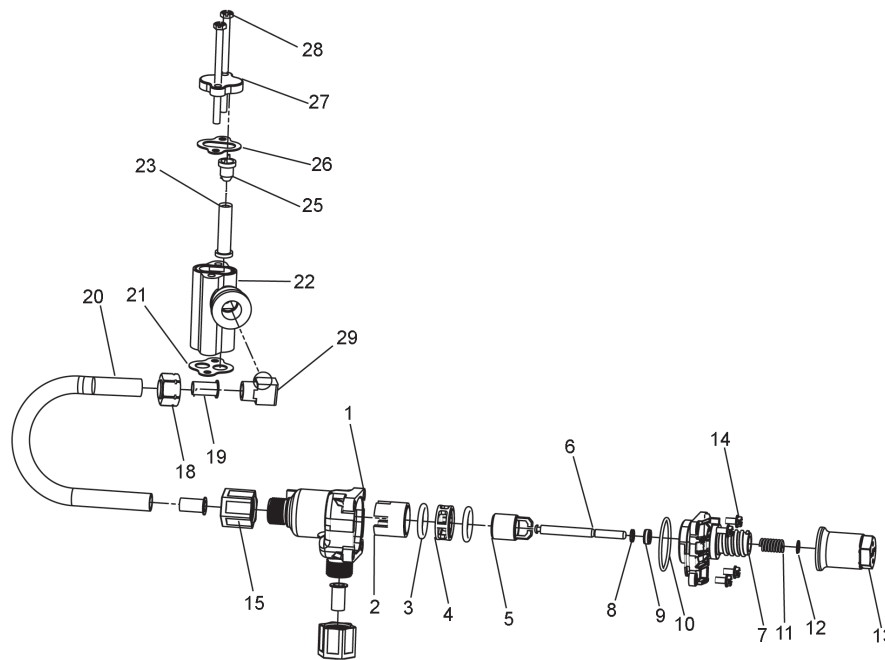

Item No.	Quantity	Part No.	Description
1	1	41202	Brine Valve, 1700, Plastic, Top
2	1	14785-01	Retainer, Flow Control
3	1	14811	O-Ring, -210, 560CD, Brine
4	1	14798	Spacer, 1700, Brine
5	1	14795	Piston, Brine Valve
6	1	41203	Stem, Brine, 1710, Plastic, 2900
7	1	41201	Brine Valve, 1700, Plastic, Bottom
8	5	17908	Sleeve, Brine Valve Stem
9	1	12550	Quad Ring, -009
10	3	41547	O-Ring, 2mmx35mm
11	2	15310	Spring, Brine Valve
12	2	10250	Ring, Retaining
13	1	17906	Guide, Brine Valve Stem
14	2	14202-01	Screw, Hex Wsh Mach, 8-32 X 5/16 18-8 Stainless Steel
15	2	41056	Nut Assembly, 1/2" Plastic
Not Shown	1	19151	Washer, Flow, 1.0 Gpm
18	1	15414	Nut, 2900, w/Sleeve
19	1	15415	Fitting, Insert, 1/2", Tube
20	1	16460	Tube, Brine, 2850, 2900s
	1	42183	Tube, Brine, 2850s
	1	15416	Tube, Brine, 2900/2750
	1	41447	Tube, Brine, 2900s U/F
21	1	19925	Gasket, Injector Body, 1700
22	1	17777	Body, Injector, 1700
23	1	14802-xxc	Throat, Injector, -xxc is Injector Size
25	1	14801-xxc	Nozzle, Injector, -xxc is Injector Size
26	1	10229	Gasket, Injector Cap, 1600
27	1	10228	Cap, Injector
28	2	14804	Screw, Hex Head Mach, 10 - 24 x 2-3/4 18-8 Stainless Steel
29	1	15413	Fitting, Elbow, Male, 1/2T X 3/8NPT

For Service Assembly Numbers, See the Back of this Manual

1600 Service Valve Operator Assembly (Old Style)

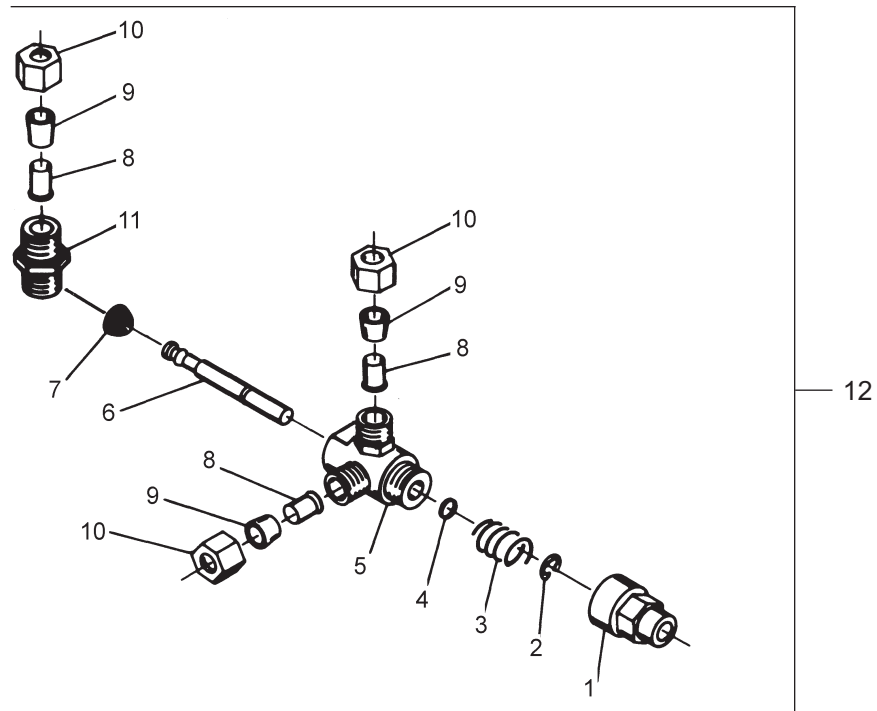

60150_REVA

Item No.	Quantity	Part No.	Description
1.....	1.....	11749.....	Guide, Brine Valve Stem
2.....	1.....	10250.....	Ring, Retaining
3.....	1.....	10249.....	Spring, Brine Valve
4.....	1.....	12550.....	Quad Ring, -009
5.....	1.....	10785.....	SVO Body Assy Brass Valves
6.....	1.....	12552-02.....	Brine Valve Stem, 1600, w/Seat
7.....	1.....	12626.....	Seat, Brine Valve
8.....	3.....	10332.....	Fitting, Insert, 3/8
9.....	3.....	10330.....	Fitting, Sleeve, 3/8 Celcon
10.....	3.....	10329.....	Fitting, Tube, 3/8 Nut, Brass
11.....	1.....	10331.....	Fitting, Compression, 1/4" x 3/8"
12.....	1.....	60150.....	Service Valve Operator, Assy, 1600, Old Style, Complete

For Service Assembly Numbers, See the Back of this Manual

1" Meter Assembly

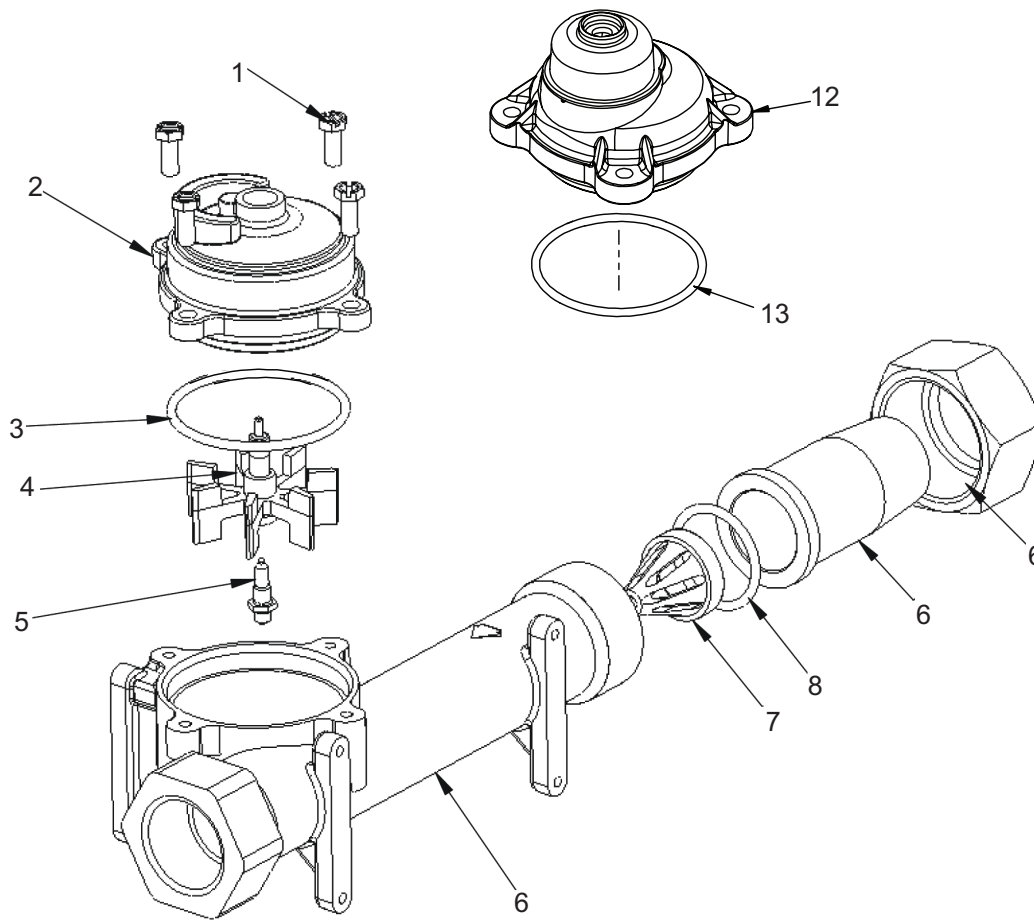

60391REVD

Item No.	Quantity	Part No.	Description
1	4	12112	Screw, Slotted Hex Head, #10 - 24 x .50
2	1	14038	Cap, Meter, STD Range, Plastic
	1	40986	Cap Meter
3	1	13847	O-ring, -137
4	1	13509	Impeller, Meter
	1	13509-01	Impeller, Celcon
5	1	13882	Post, Meter Impeller
6	1	14959	Body, Meter, 27550
	1	60628NP	Meter Assy, 1", NP
		14959	Body, Meter, 2750
		14961	Fitting, Nipple, 1", Quick Connect
		14962	Nut, 1" Meter, Quick Connect
7	1	14960	Flow Straightener
8	1	13287	O-ring, 123
12	1	15150	Meter Cap Assy, Ext, Range, Plastic
13	1	13847	O-ring, -137

Not Shown

	1	15218	Meter Cap Assy, STD Range, Brass
	1	15237	Meter Cap Assy, EXT Range, Brass

1-1/2" Meter Assembly

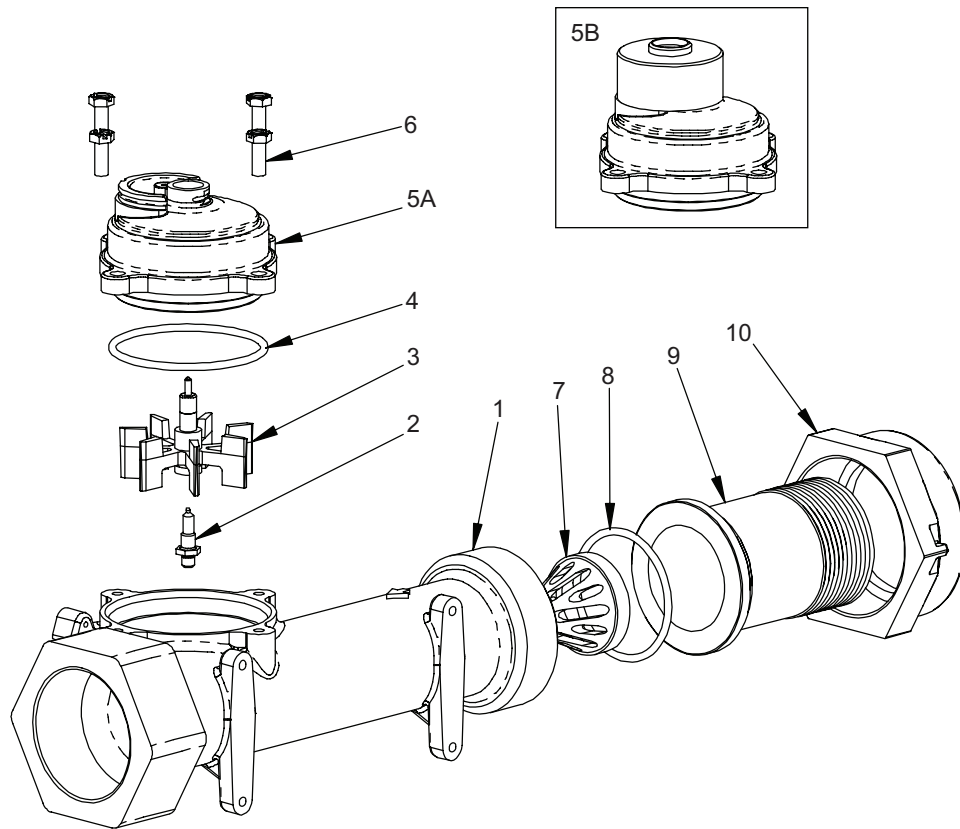

60610 REV C

Item No.	Quantity	Part No.	Description
1	1	17569	Body, Meter, 2850/9500
2	1	13882	Post, Meter Impeller
3	1	13509	Impeller, Meter
4	1	13847	O-Ring, -137, Std/560CD, Meter
5A	1	14038	Meter Cap Assy, STD Range, Plastic
5B	1	15150	Meter Cap Assy, Ext Range, Plastic
6	4	12112	Screw, Hex Hd Mach, 10-24 x 1/2 18-8 Stainless Steel
7	1	17542	Flow Straightener, 1-1/2"
8	1	12733	O-Ring, -132
9	1	17544	Fitting, 1-1/2" Quick Connector
10	1	17543	Nut, 1-1/2", Q/C

Not Shown

	1	17790	Sleeve, Meter, 1 1/2" x 1"
	1	15218	Meter Cap Assy, STD Range, Brass
	1	15237	Meter Cap Assy, EXT Range, Brass

2310 Safety Brine Valve

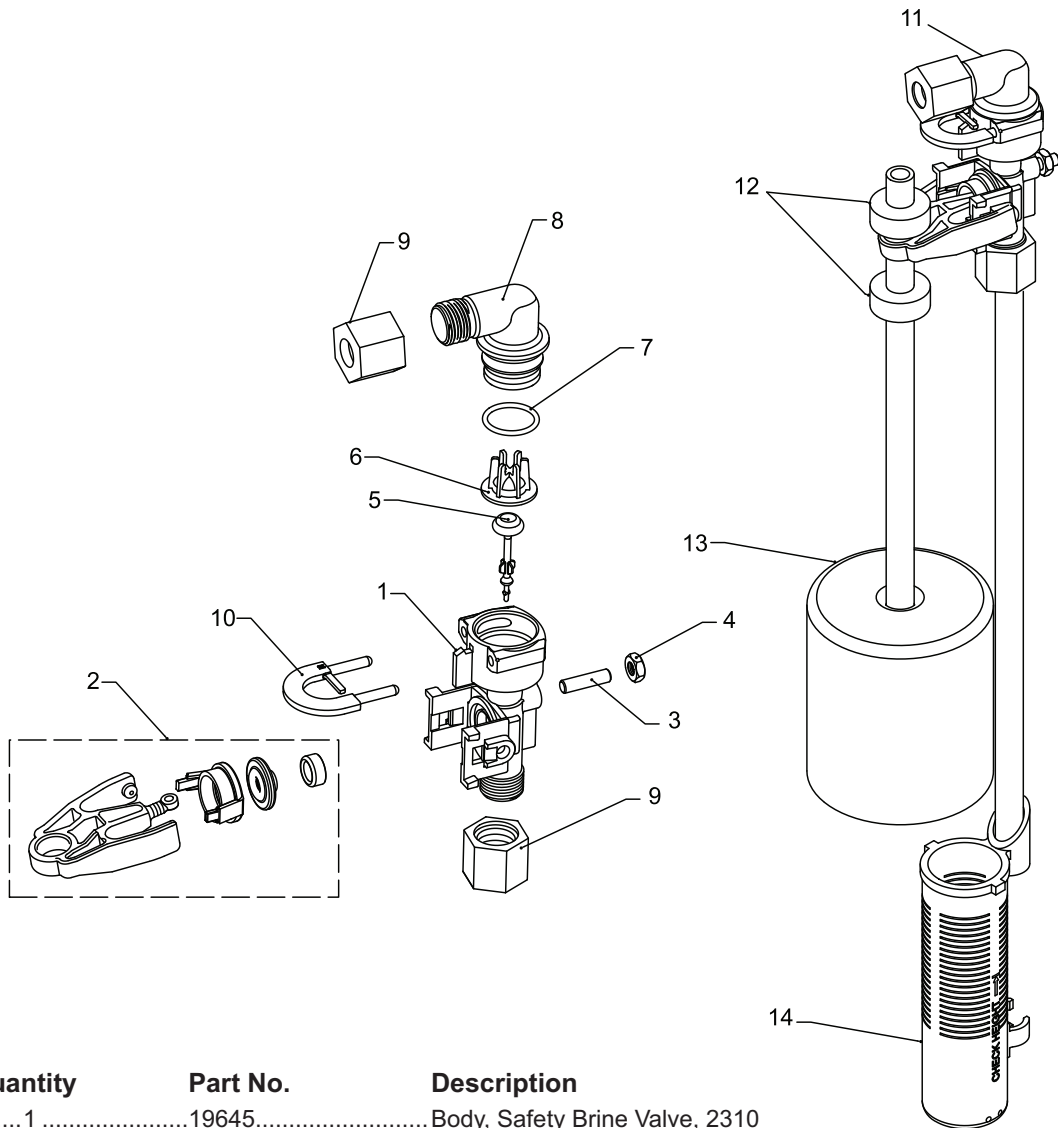

Item No.	Quantity	Part No.	Description
1	1	19645	Body, Safety Brine Valve, 2310
2	1	19803	Safety Brine Valve Assy
3	1	19804	Screw, Sckt Hd, Set, 10-24 x .75
4	1	19805	Nut, Hex, 10-24, Nylon Black
5	1	19652-01	Poppet Assy, SBV w/O-ring
6	1	19649	Flow Dispenser
7	1	11183	O-ring, -017
8	1	19647	Elbow, Safety Brine Valve
9	2	19625	Nut Assy, 3/8" Plastic
10	1	18312	Retainer, Drain
11	1	60014	Safety Brine Valve Assy, 2310
12	2	10150	Grommet, .30 Dia
13	1	60068-30	Float Assy, 2310, w/30" Rod
14	1	60002-34	Air Check, #500, 34" Long

42112_REVA

2350 Safety Brine Valve

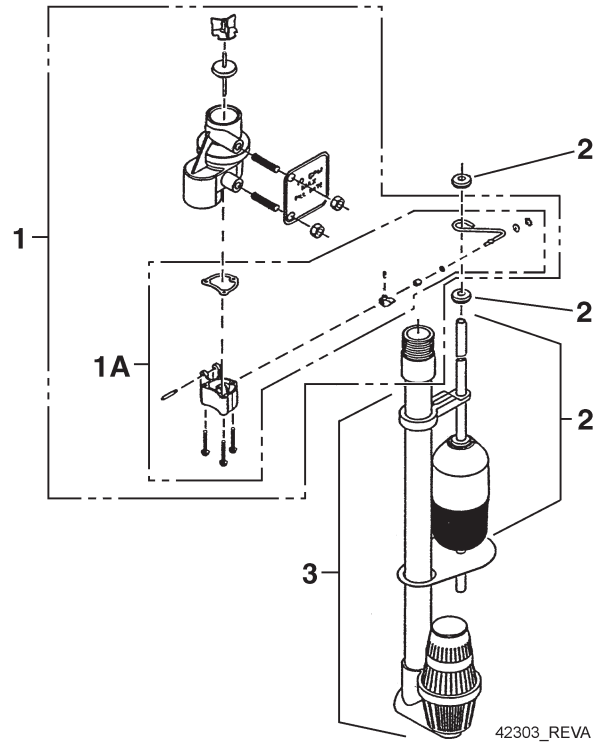

Item No.	Quantity	Part No.	Description
1	1	60038	Safety Brine Valve, 2350
1A	1	61024	Actuator Assy, 2350 Brine
2	1	60028-30	Float Assy, 2350, 30" Wht
	1	60026-30SAN	Float Assy, 2350, 30" Hot Water
3	1	60009-00	Air Check, #900, Commercial Less Fittings
	1	60009-01	Air Check, #900, Commercial, Hot Water Less Fittings

Not Shown

	1	18603	Fitting Assy, 900 Air Check 2350
	1	18602	Fitting Assy, 900 Air Check

Seal & Spacer Tools & Replacement

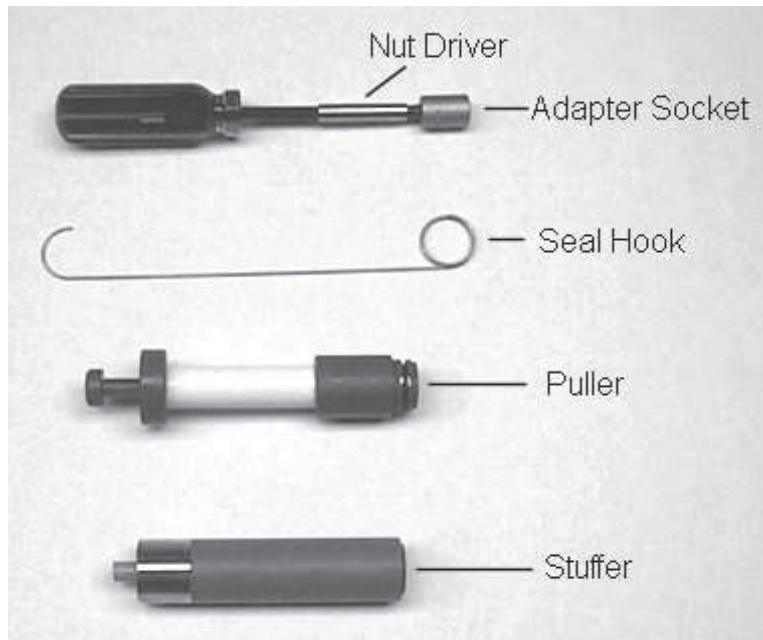

Tools Used in the Seal and Spacer Replacement

Description	Part No.
Nut Driver	12664
Socket Adapter	16906
Socket 7/16"	12665
Seal Hook	12874
Puller	13061, 1500/2510/5600/4650
.....	17623, 2850/9500
.....	12682, 2900/3180
Stuffer	11098, 1500/2510/2750
.....	12763, 5600/9000/9100/4650
.....	12683, 2100/3150
.....	16516, 2850/9500

Seal & Spacer Tools & Replacement

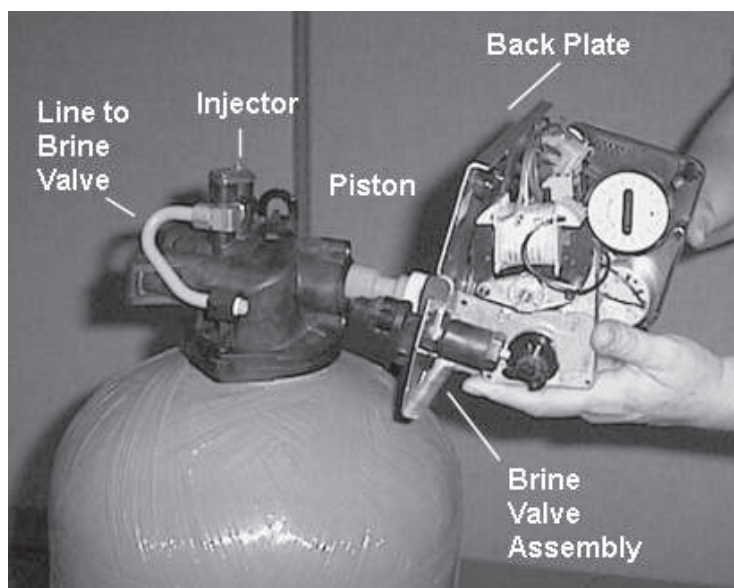

Figure 5

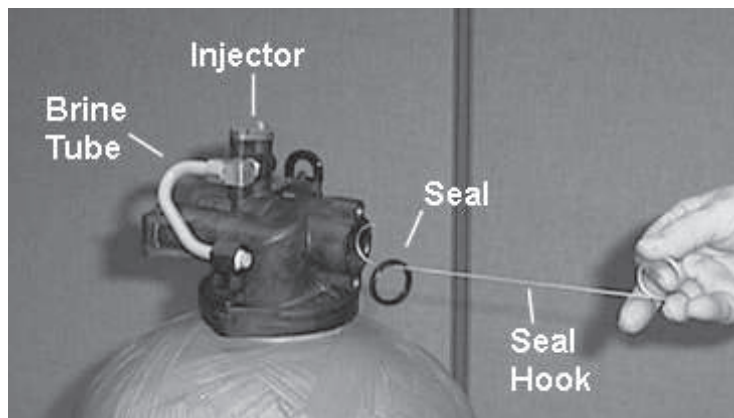

Figure 6

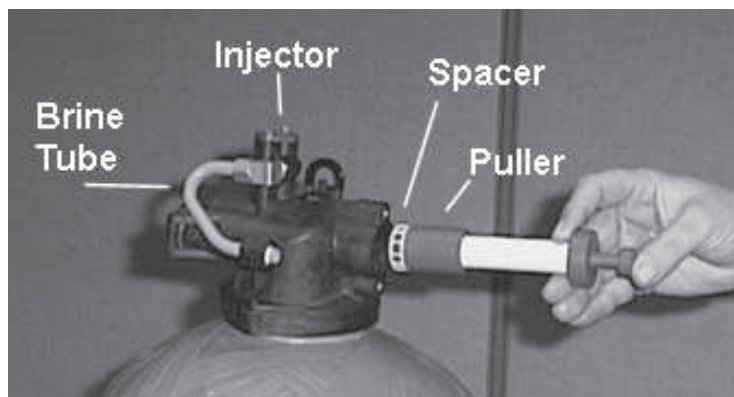

Figure 7

NOTE: Photos shown are for reference only for replacing the seal and spacer. Actual valve may be different.

1. Turn off water supply to valve. Next, cycle valve to backwash position, then to service. Now remove electrical plug from outlet.
2. Remove control box cover.
3. Disconnect the brine line from the injector housing to the brine valve (if your unit has timed brine tank fill).
4. Remove the two capscrews that hold the back plate to the valve.
5. Grasp the back plate on both sides and slowly pull end plug and piston assembly out of the valve body (see Figure 5) and lay aside.
6. Remove the seal first using the wire hook with the finger loop (see Figure 6).
7. The spacer tool (use only for removing the spacers) has three retractable pins, retained by a rubber ring, at one end. They are retracted or pushed out by pulling or pushing the center button the opposite end.
8. Insert the pin end of the spacer tool into the valve body with the pins retracted (button pulled back). Push the tool tight against the spacer and push the button in, (see Figure 7). When the button is pushed in, the pins are pushed out to engage the 1/4 dia. holes in the spacer. Remove the tool from the valve body. The spacer will be on the end. Pull the center button back, the pins will be retracted and the spacer can be removed from the spacer tool.

Seal & Spacer Tools & Replacement

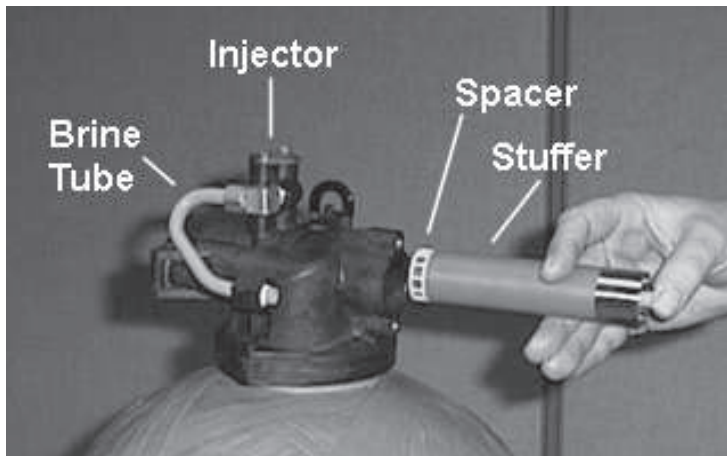

Figure 8

9. Alternately remove the remaining seals and spacers in accordance with steps No. 6 and 8.
10. The last or end spacer does not have any holes for the pins of the spacer tool to engage, therefore if the end spacer does not come out on the first try, try again using the wire hook with the finger loop.
11. To replace seals, spacers and end ring, use special tool with the brass sleeve on one end. This is a double-purpose tool (see Figure 8). The male end acts as a pilot to hold the spacers as they are pushed into the valve body and the brass female end is used to insert the seals into the valve body.
12. To restuff a valve body, first take the end ring (the plastic or brass ring without holes), then with your thumb press the button on the brass sleeve end. The large dia. inner portion is now exposed (see Figure 8). Place the end ring on this pilot with the lip on the end ring facing the tool. Push the tool into the valve body bore until it bottoms. While the tool is in the valve body, take a seal and press it into the inside diameter of the exposed brass female end.
13. Remove the tool, turn it end for end and insert it into the valve body bore. While holding the large dia. of the tool, slide it all the way into the valve body bore until it bottoms. Then push the center button to push the seal of the tool and leave it in place in the valve body.
14. Remove the tool from the valve body and push the center on the brass female end to expose the pilot on the opposite end. Place a spacer on this end and insert the spacer and tool into the valve.

Troubleshooting

Problem	Cause	Correction
1. Water conditioner fails to regenerate.	A. Electrical service to unit has been interrupted	A. Assure permanent electrical service (check fuse, plug, pull chain, or switch)
	B. Timer is defective.	B. Replace timer.
	C. Power failure.	C. Reset time of day.
2. Hard water.	A. By-pass valve is open.	A. Close by-pass valve.
	B. No salt is in brine tank.	B. Add salt to brine tank and maintain salt level above water level.
	C. Injector screen plugged.	C. Clean injector screen.
	D. Insufficient water flowing into brine tank.	D. Check brine tank fill time and clean brine line flow control if plugged.
	E. Hot water tank hardness.	E. Repeated flushings of the hot water tank is required.
	F. Leak at distributor tube.	F. Make sure distributor tube is not cracked. Check O-ring and tube pilot.
	G. Internal valve leak.	G. Replace seals and spacers and/or piston.
3. Unit used too much salt.	A. Improper salt setting.	A. Check salt usage and salt setting.
	B. Excessive water in brine tank.	B. See problem 7.
4. Loss of water pressure.	A. Iron buildup in line to water conditioner.	A. Clean line to water conditioner.
	B. Iron buildup in water conditioner.	B. Clean control and add mineral cleaner to mineral bed. Increase frequency of regeneration.
	C. Inlet of control plugged due to foreign material broken loose from pipes by recent work done on plumbing system.	C. Remove piston and clean control.
5. Loss of mineral through drain line.	A. Air in water system.	A. Assure that well system has proper air eliminator control. Check for dry well condition.
	B. Improperly sized drain line flow control.	B. Check for proper drain rate.
6. Iron in conditioned water.	A. Fouled mineral bed.	A. Check backwash, brine draw, and brine tank fill. Increase frequency of regeneration. Increase backwash time.
7. Excessive water in brine tank.	A. Plugged drain line flow control.	A. Clean flow control.
	B. Plugged injector system.	B. Clean injector and screen.
	C. Timer not cycling.	C. Replace timer.
	D. Foreign material in brine valve.	D. Replace brine valve seat and clean valve.
	E. Foreign material in brine line flow control.	E. Clean brine line flow control.

Troubleshooting

Problem	Cause	Correction
8. Softener fails to draw brine.	A. Drain line flow control is plugged.	A. Clean drain line flow control.
	B. Injector is plugged.	B. Clean injector
	C. Injector screen plugged.	C. Clean screen.
	D. Line pressure is too low.	D. Increase line pressure to 20 psi
	E. Internal control leak	E. Change seals, spacers, and piston assembly.
	F. Service adapter did not cycle.	F. Check drive motor and switches.
9. Control cycles continuously.	A. Misadjusted, broken, or shorted switch.	A. Determine if switch or timer is faulty and replace it, or replace complete power head.
10. Drain flows continuously.	A. Valve is not programming correctly.	A. Check timer program and positioning of control. Replace power head assembly if not positioning properly.
	B. Foreign material in control.	B. Remove power head assembly and inspect bore. Remove foreign material and check control in various regeneration positions.
	C. Internal control leak.	C. Replace seals and piston assembly.

General Service Hints For Meter Control

Problem: Softener delivers hard water

Reason: Reserve capacity has been exceeded.

Correction: Check salt dosage requirements and reset program wheel to provide additional reserve.

Reason: Program wheel is not rotating with meter output.

Correction: Pull cable out of meter cover and rotate manually. Program wheel must move without binding and clutch must give positive clicks when program wheel strikes regeneration stop. If it does not, replace timer.

Reason: Meter is not measuring flow.

Correction: Check meter with meter checker.

Water Conditioner Flow Diagrams

1 Service Position

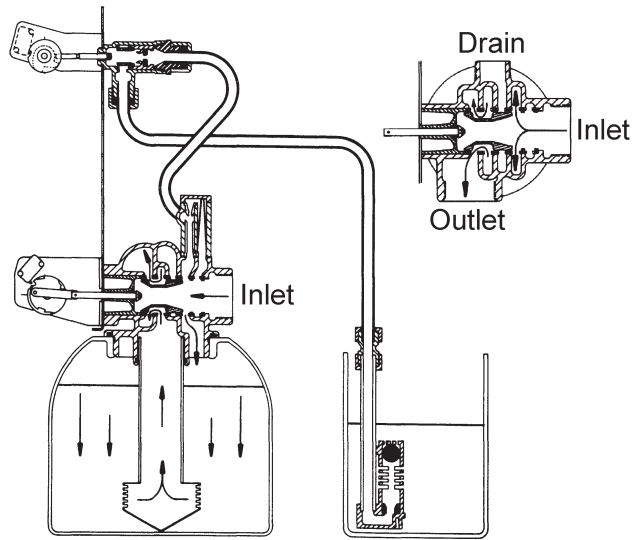

Hard water enters unit at valve inlet and flows down through the mineral in the mineral tank. Conditioned water enters center tube through the bottom distributor, then flows up through the center tube, around the piston, and out the outlet of the valve.

2 Backwash Position

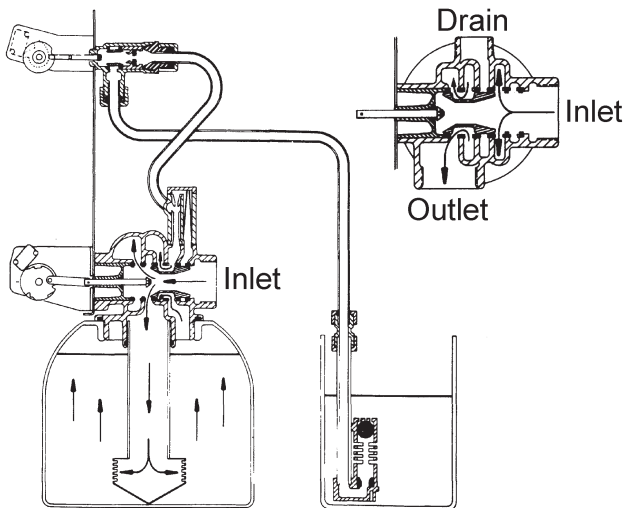

Hard water enters unit at valve inlet, flows through piston, down center tube, through bottom distributor, and up through the mineral, around the piston and out the drain line.

3 Brine Position

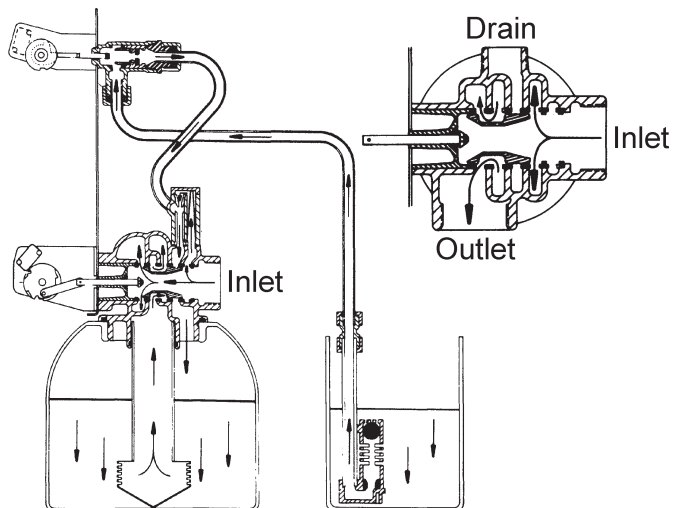

Hard water enters unit at valve inlet, flows up into injector housing and down through nozzle and throat to draw brine from the brine tank, brine flows down through mineral and enters the center tube through bottom distributor and out through the drain line.

Water Conditioner Flow Diagrams

4 Slow Rinse Position

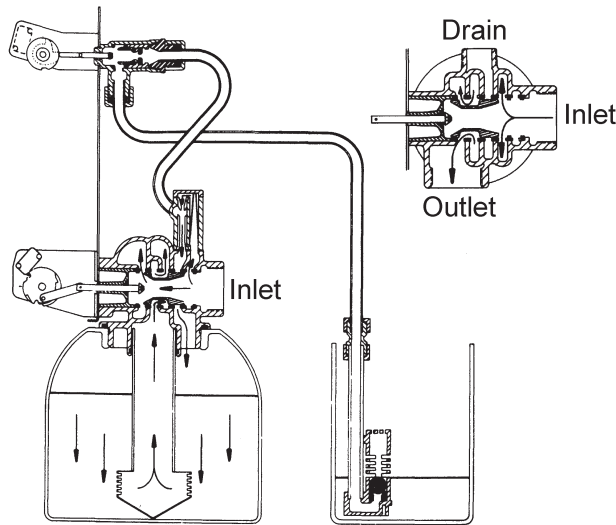

Hard water enters unit at valve inlet, flows up into injector housing and down through nozzle and throat, around the piston, down through mineral, enters center tube through bottom distributor, flows up through center tube, around piston and out through drain line.

5 Rapid Rinse

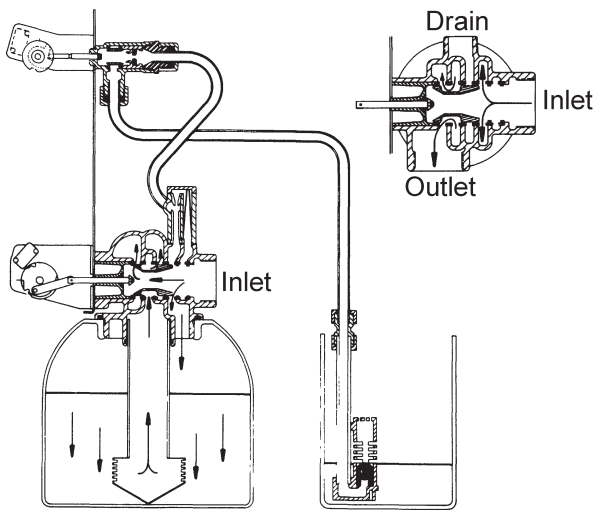

Hard water enters unit at valve inlet, flows directly from inlet down through mineral into center tube bottom distributor and up through center tube, around piston and out through the drain line.

6 Brine Tank Refill Position

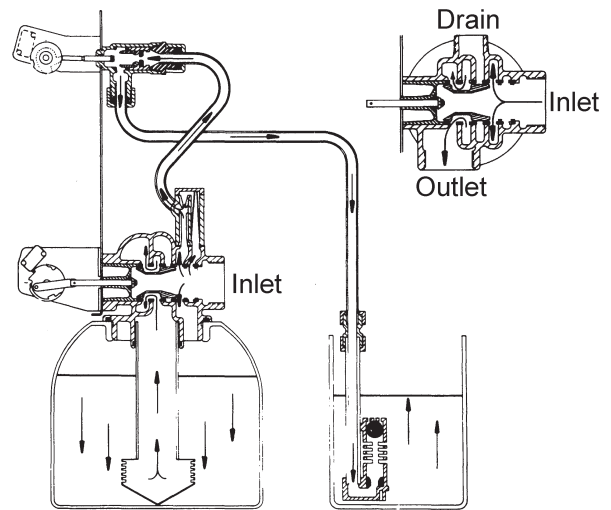

Hard water enters unit at valve inlet, flows up through the injector housing, through the brine valve to refill the brine tank.

Flow Data & Injector Draw Rates

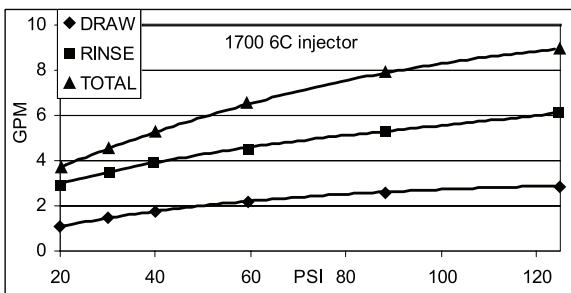
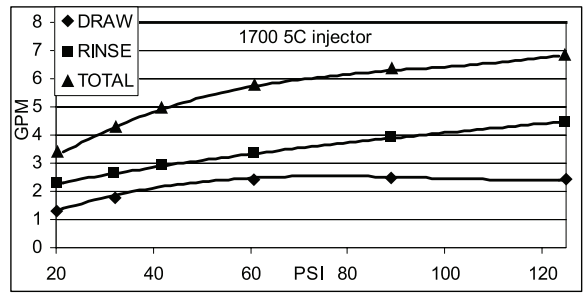
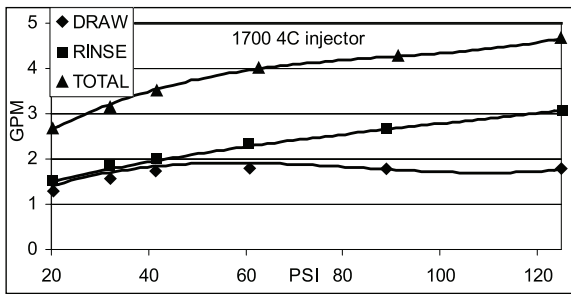
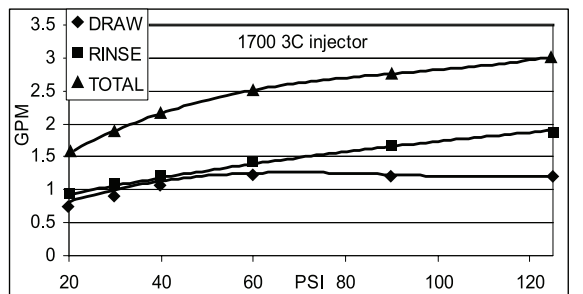
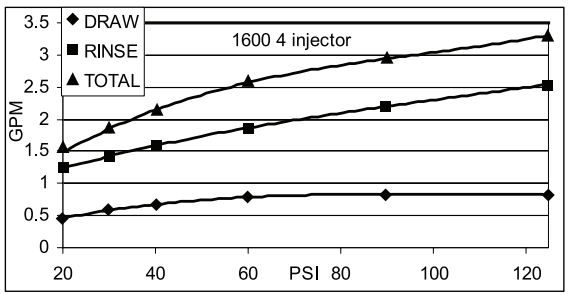
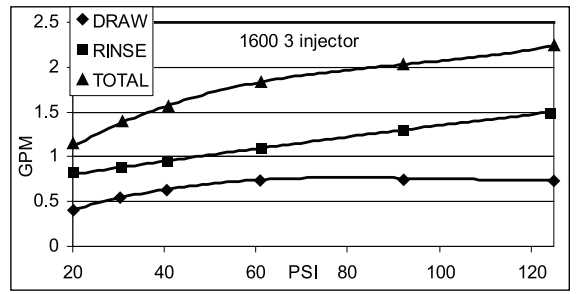
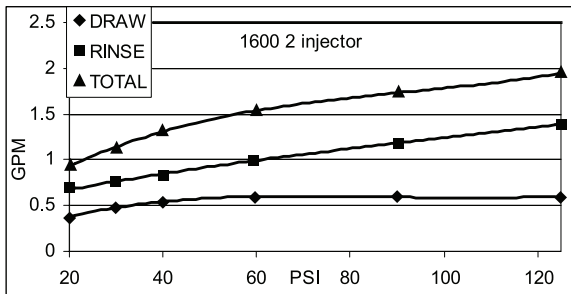
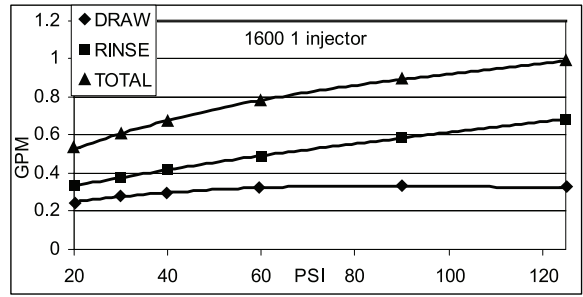
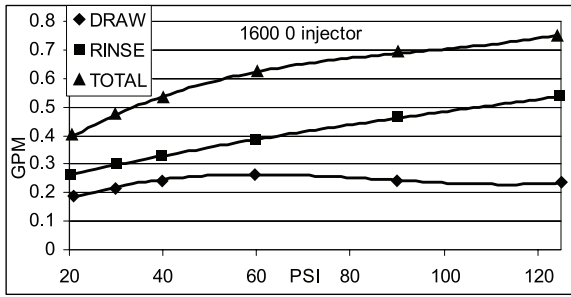

TR20391_REVA

Dimensions

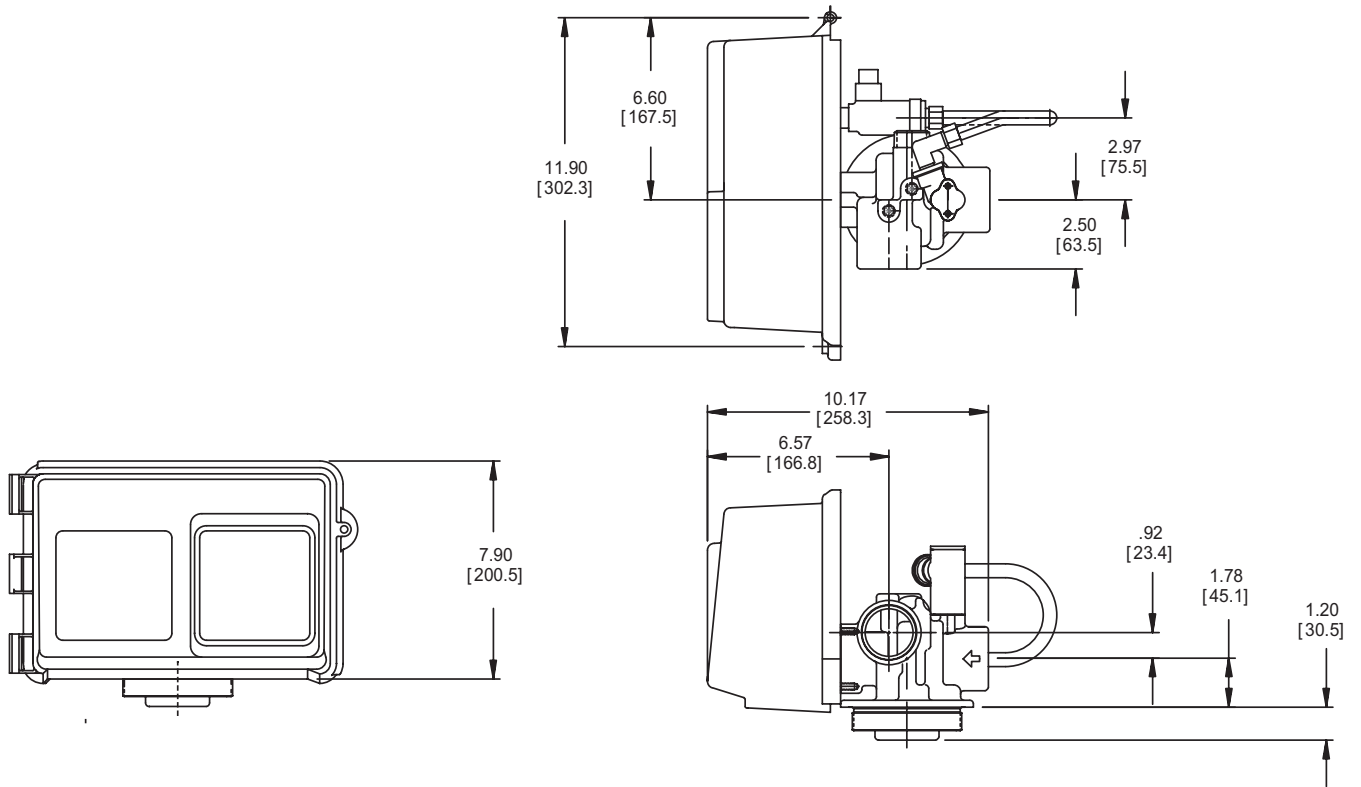

61500-2850 LNE REV A

System #4 - Typical Single Tank Installation with Optional Meter

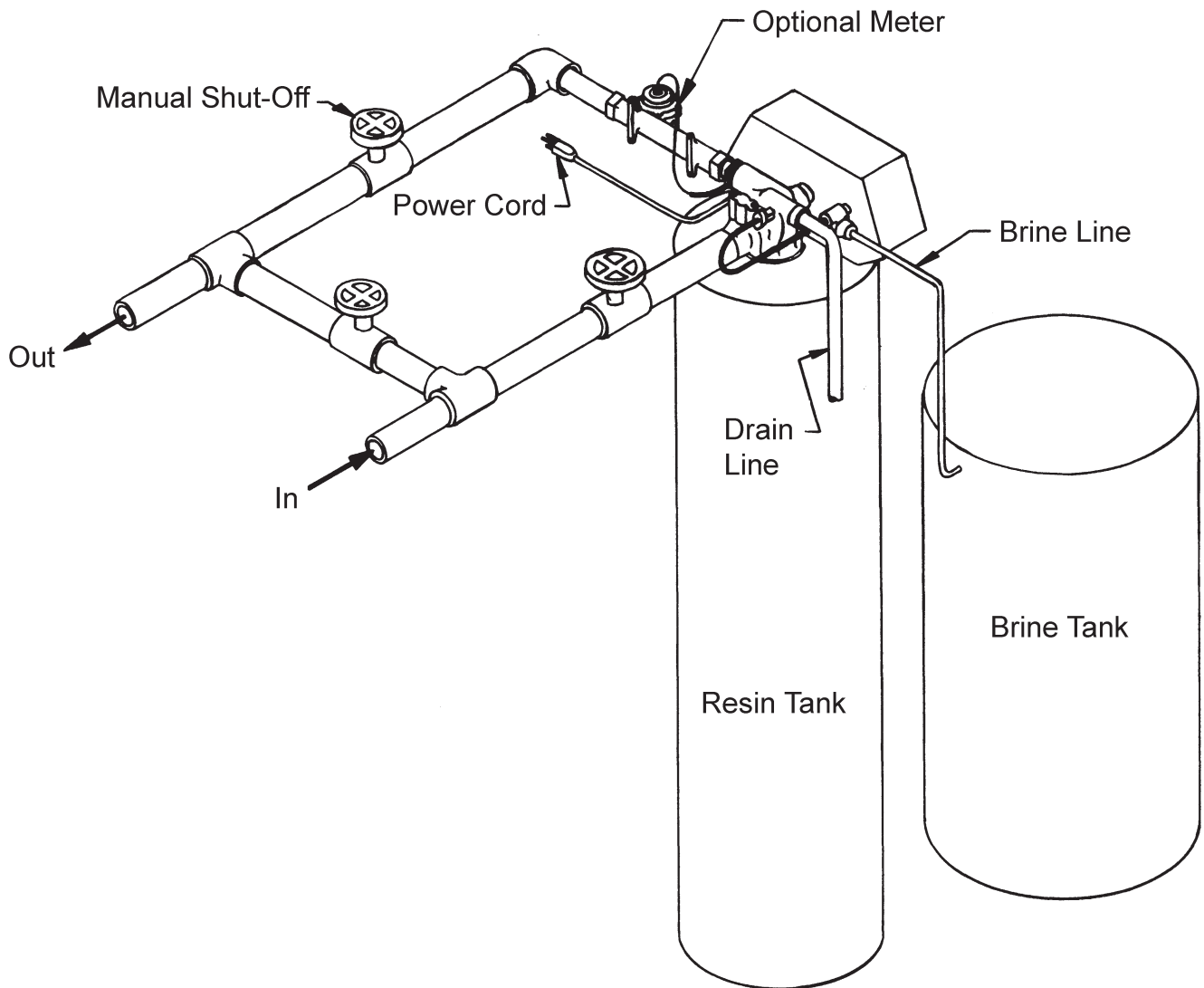

System #5 Interlock - Typical Twin Tank Installation with Optional Meter Interlock and No Hard Water Bypass

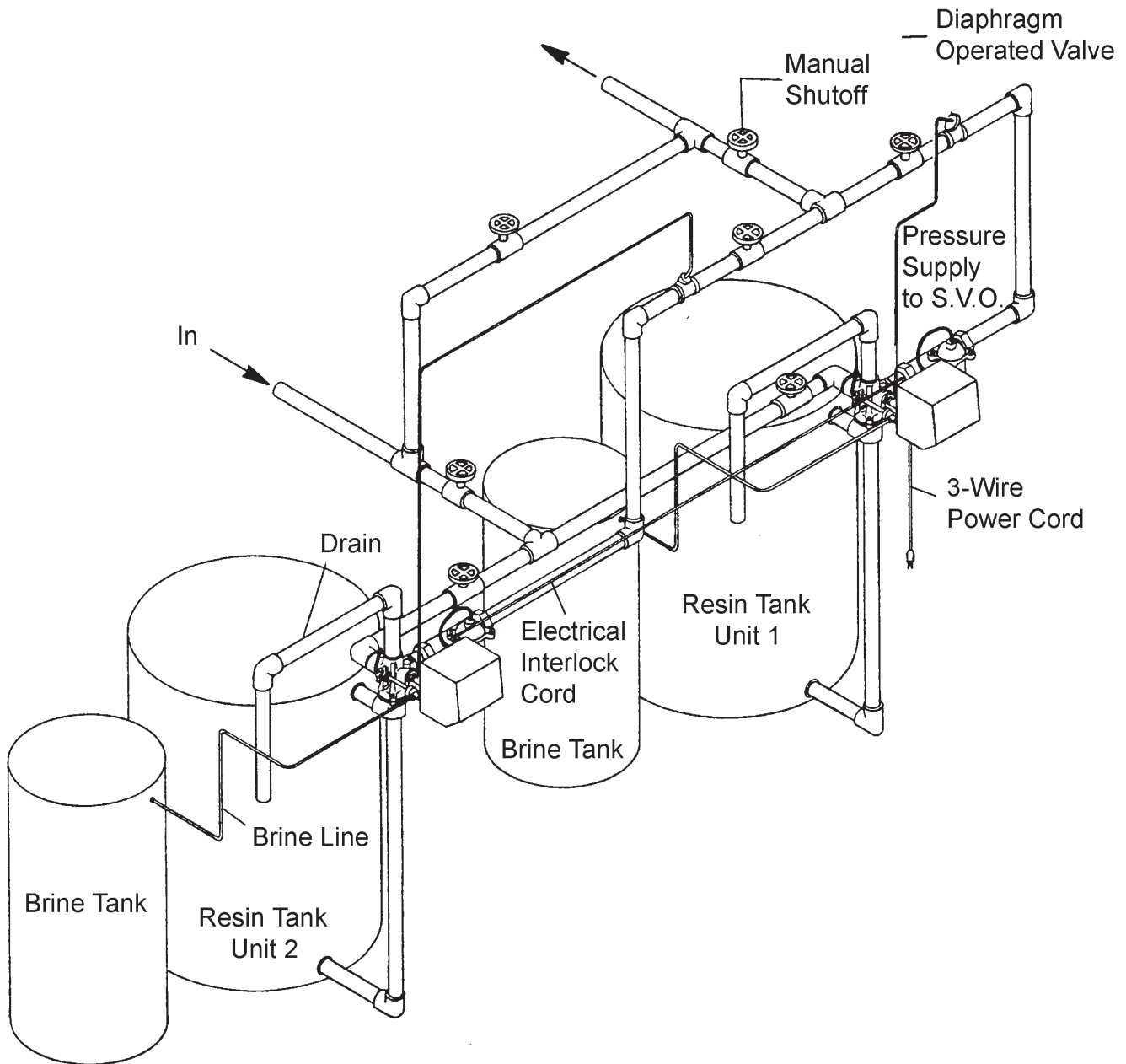

System #6 - Twin Series Regeneration Installation with a Remote Meter

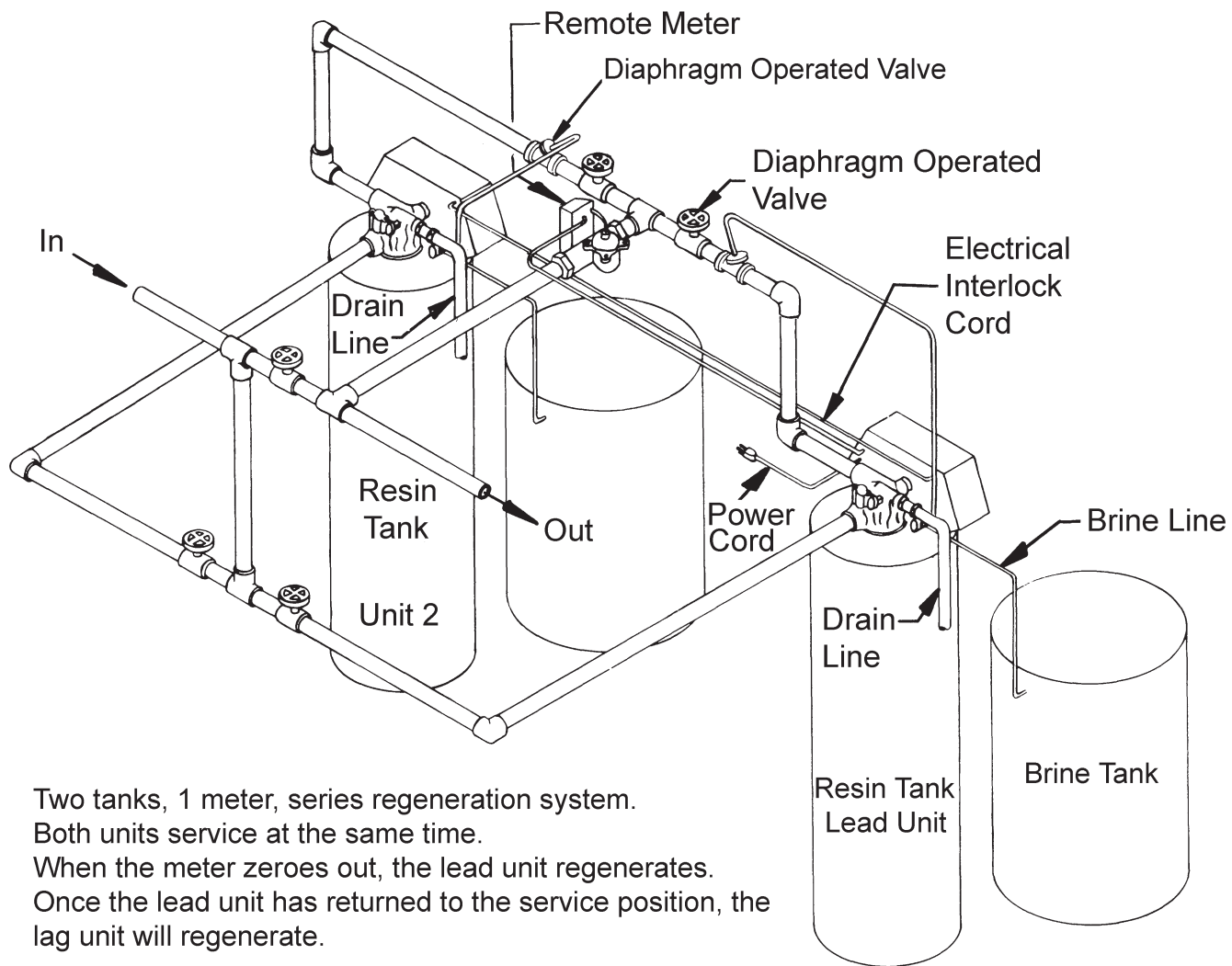

Two tanks, 1 meter, series regeneration system.
Both units service at the same time.
When the meter zeroes out, the lead unit regenerates.
Once the lead unit has returned to the service position, the lag unit will regenerate.

System #7 - Twin Alternator Installation with a Remote Meter

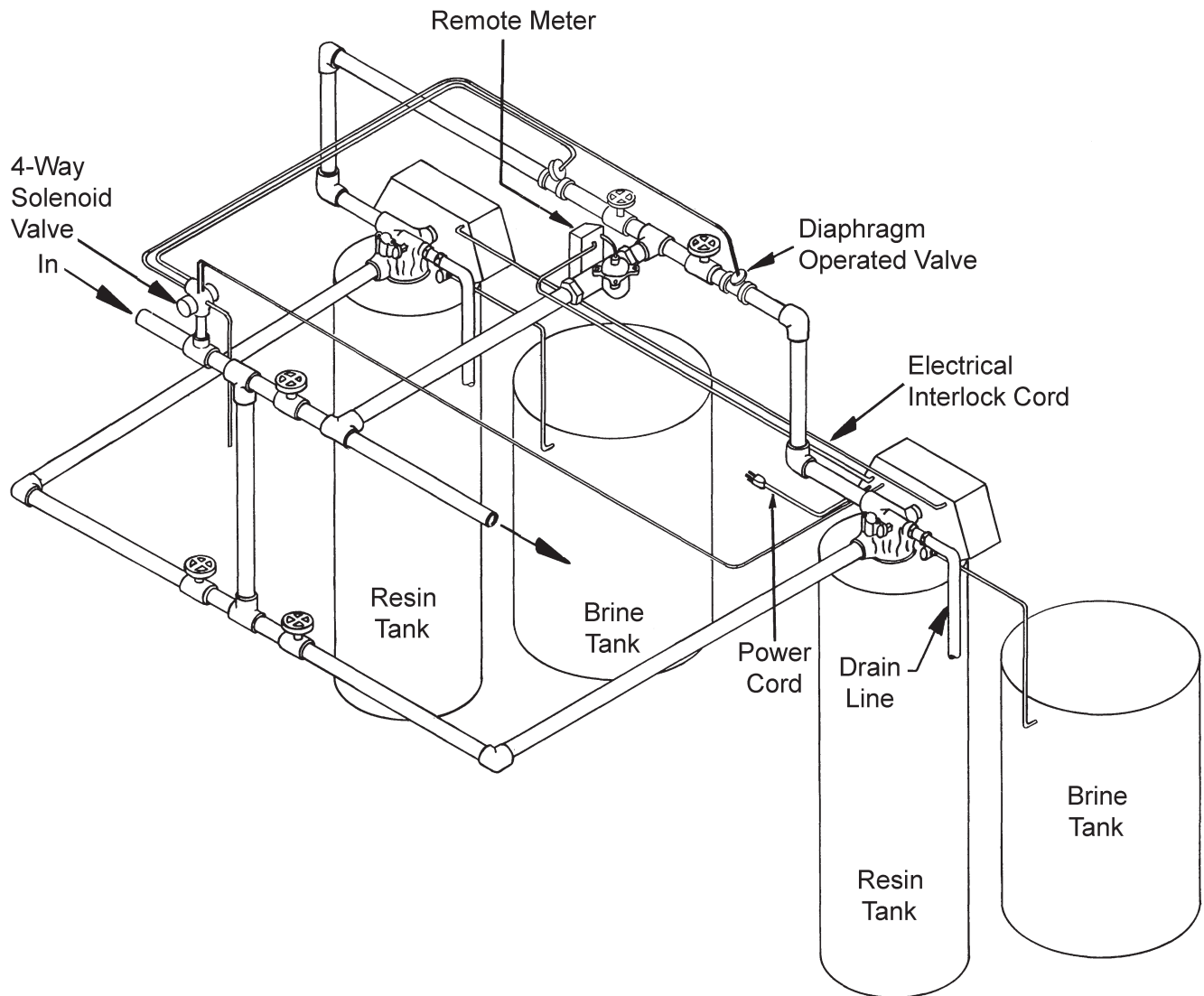

System #4 - Single Valve Regeneration

Immediate and Delayed Valve Wiring

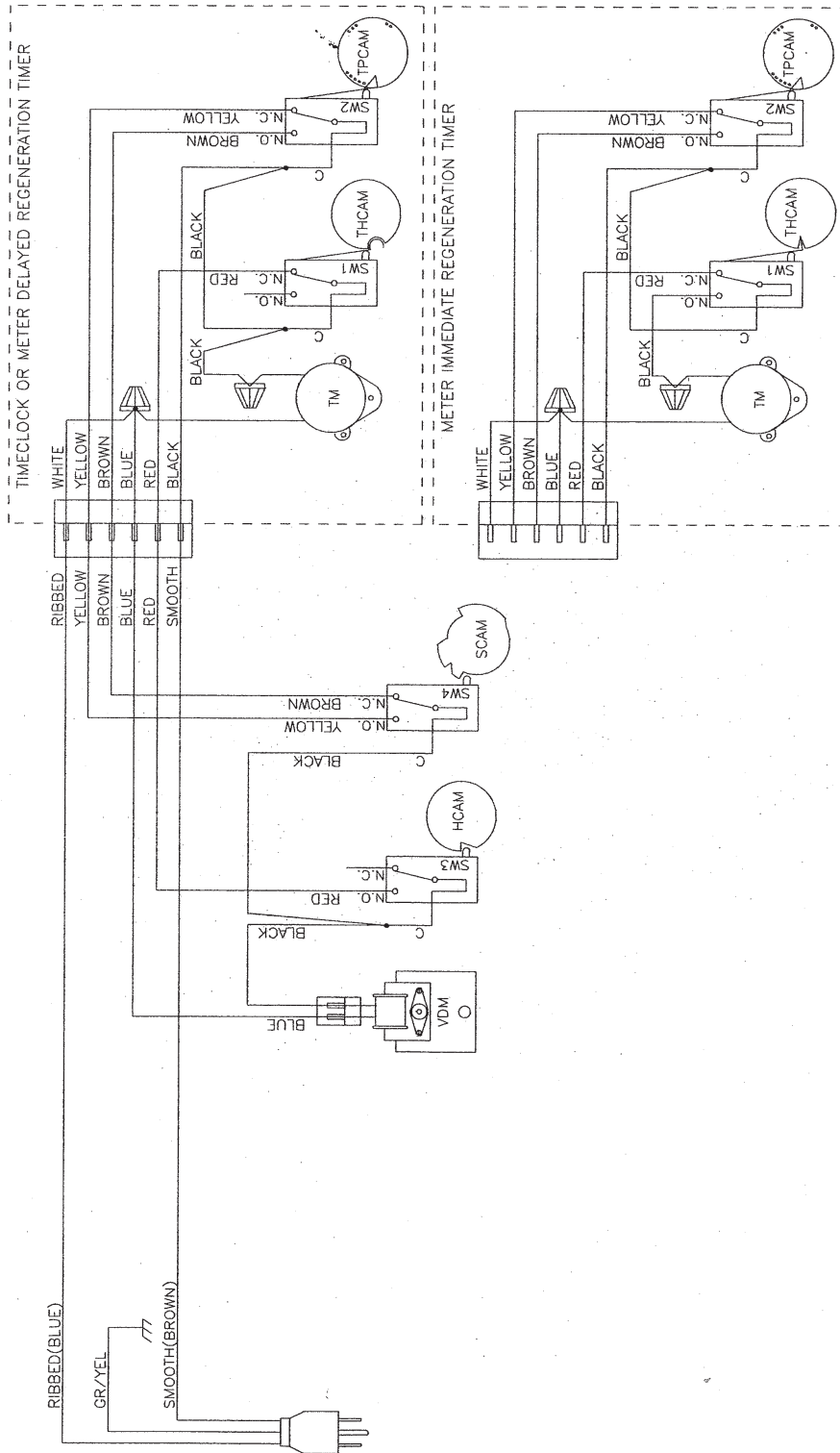

19201_REV B

System #4 - with Remote Starter Valve Wiring

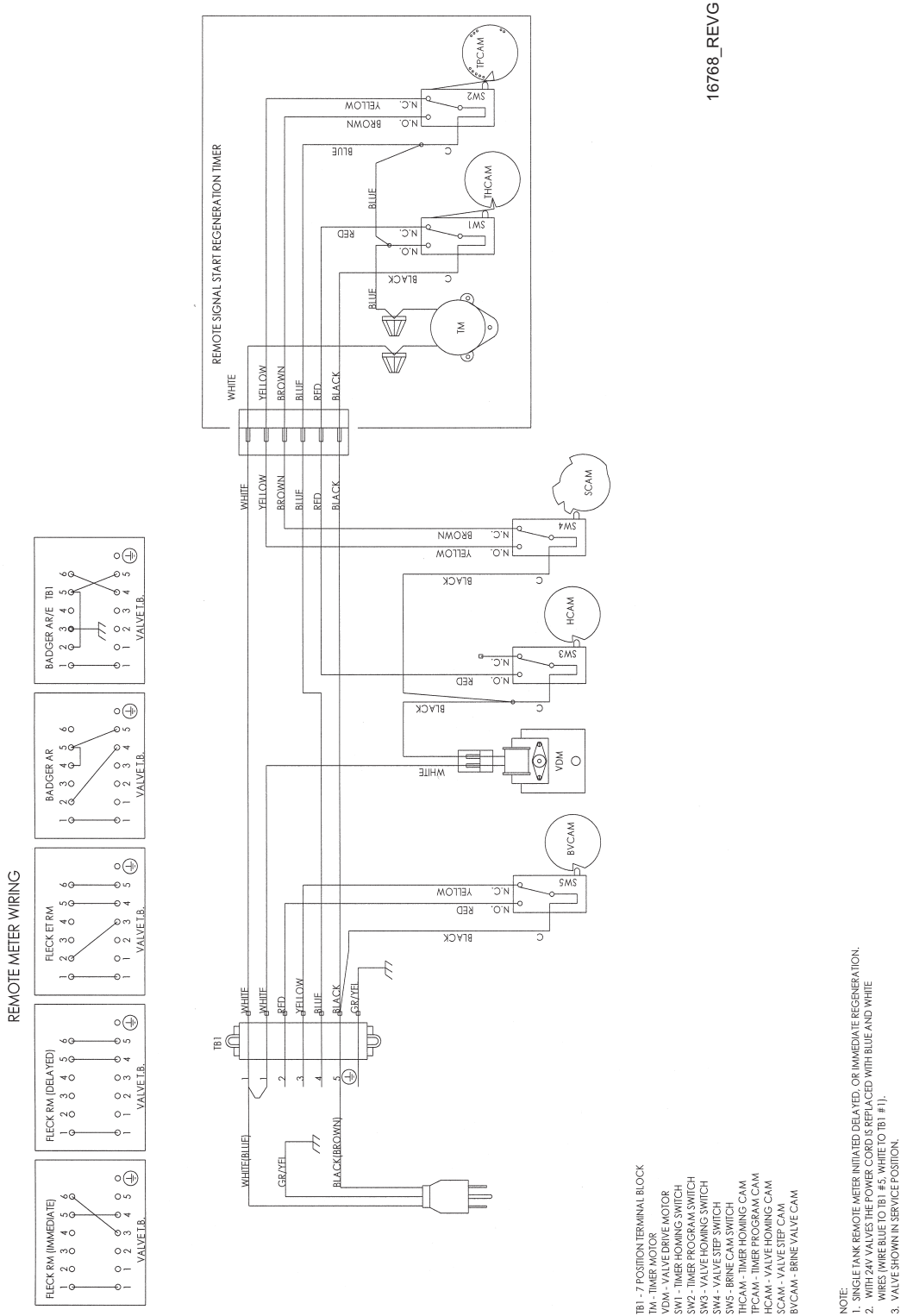

16768_REV G

System #5 - Interlocked Regeneration

Valve Wiring

7847 1 PRODUCTION RELEASED
9726 B ADDED SHEET 2

LEAD

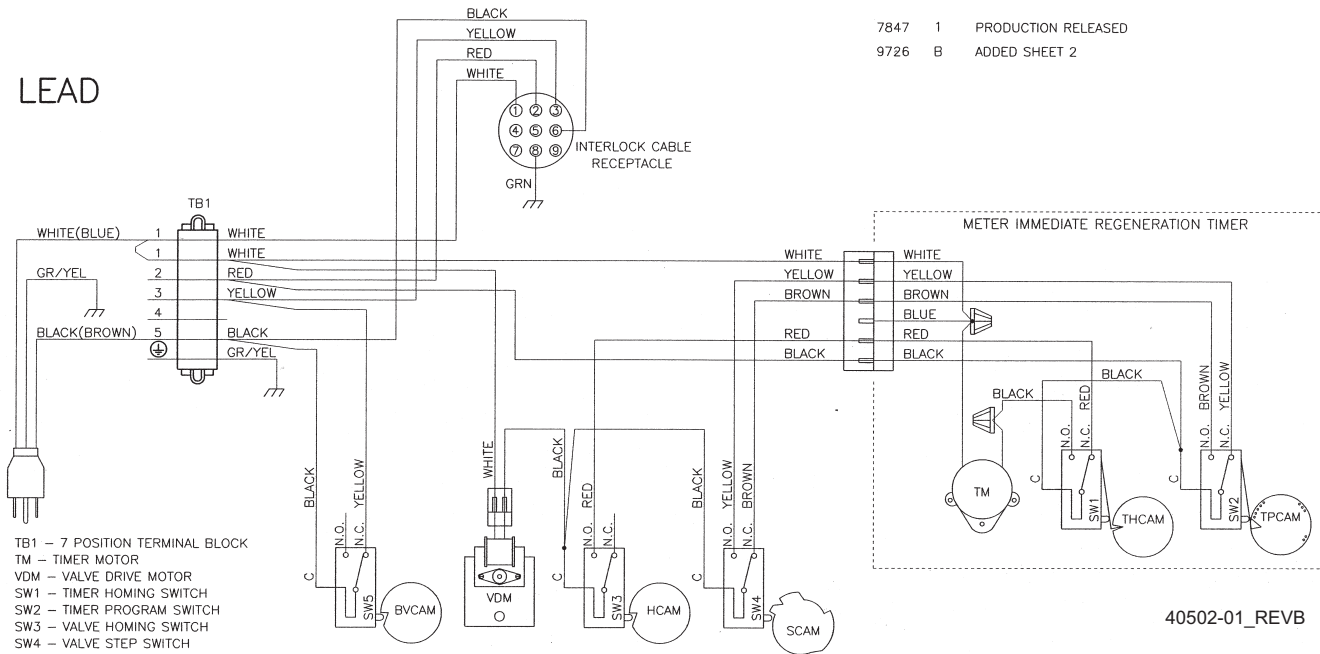

NOTE:
 1. BOTH VALVES IN SERVICE, ONLY ONE VALVE IN REGENERATION AT A TIME.
 2. INDIVIDUAL LOCAL METER REGENERATION.
 3. VALVE SHOWN IN SERVICE.

40502-01_REV B

LAG

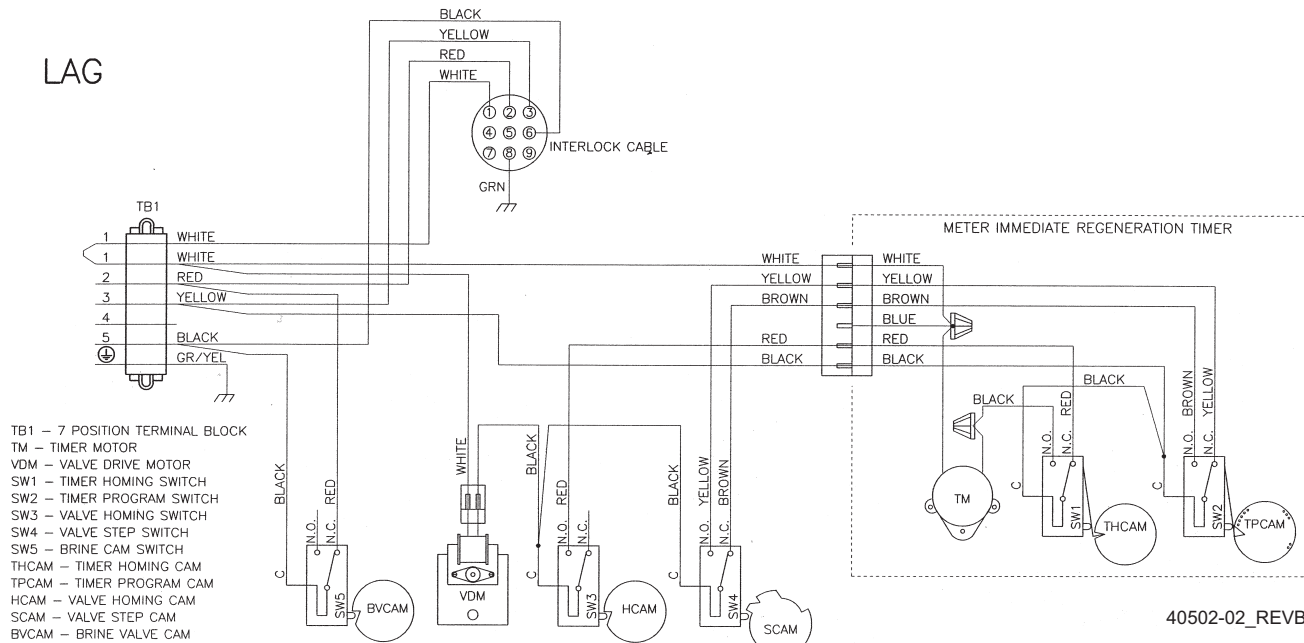

NOTE:
 1. BOTH VALVES IN SERVICE, ONLY ONE VALVE IN REGENERATION AT A TIME.
 2. INDIVIDUAL LOCAL METER REGENERATION.
 3. VALVE SHOWN IN SERVICE.

40502-02_REV B

System #6 - Series Regeneration Valve Wiring

REMOTE METER WIRING

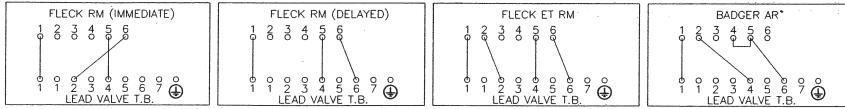

LEAD

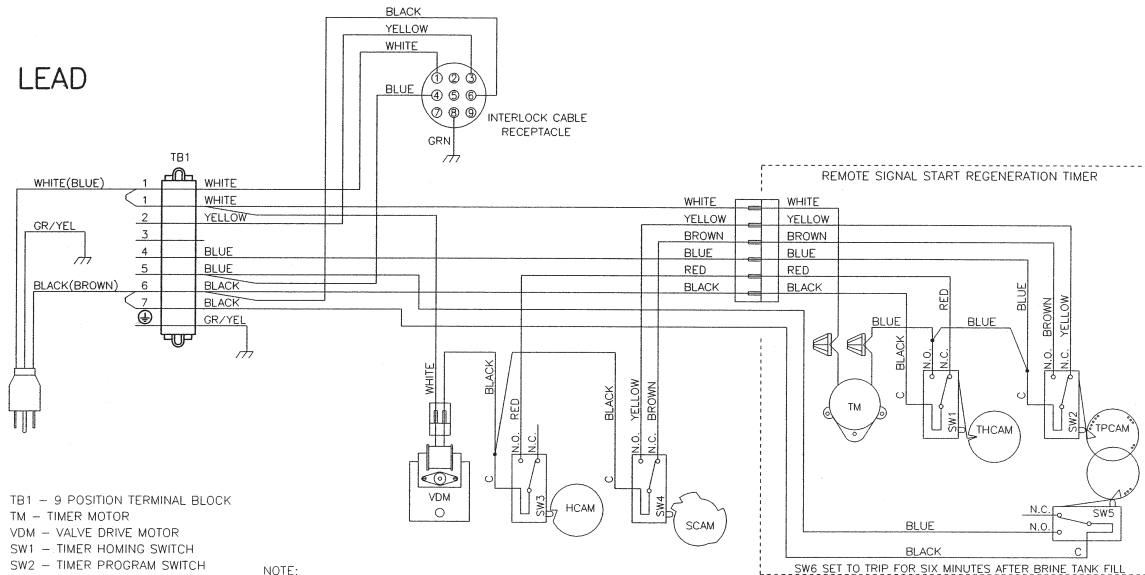

- TB1 - 9 POSITION TERMINAL BLOCK
 TM - TIMER MOTOR
 VDM - VALVE DRIVE MOTOR
 SW1 - TIMER HOMING SWITCH
 SW2 - TIMER PROGRAM SWITCH
 SW3 - VALVE HOMING SWITCH
 SW4 - VALVE STEP SWITCH
 SW5 - AUXILIARY TIMER SWITCH
 THCAM - TIMER HOMING CAM
 TPCAM - TIMER PROGRAM CAM
 HCAM - VALVE HOMING CAM
 SCAM - VALVE STEP CAM

NOTE:

1. TWO TANK INTERLOCKED, SINGLE REMOTE METER, SERIES REGENERATION.
2. BOTH TANKS NORMALLY IN SERVICE.
3. ONLY ONE TANK IN REGENERATION, THE OTHER REMAINS IN SERVICE.
4. LEAD VALVE REGENERATES FIRST, FOLLOWED IMMEDIATELY BY LAG VALVE.
5. WITH 24V VALVES THE POWER CORD IS REPLACED WITH BLUE AND WHITE WIRES (WIRE BLUE TO TB1 #6, WHITE TO TB1 #1).
6. VALVE SHOWN IN SERVICE POSITION.

13632-01_REVK

LAG

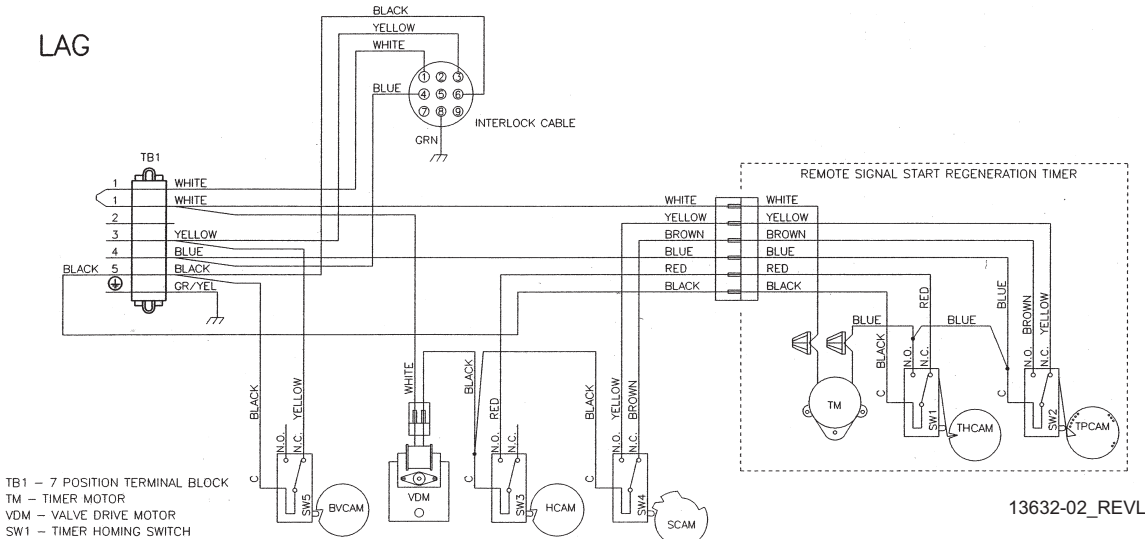

- TB1 - 7 POSITION TERMINAL BLOCK
 TM - TIMER MOTOR
 VDM - VALVE DRIVE MOTOR
 SW1 - TIMER HOMING SWITCH
 SW2 - TIMER PROGRAM SWITCH
 SW3 - VALVE HOMING SWITCH
 SW4 - VALVE STEP SWITCH
 SW5 - BRINE CAM SWITCH
 THCAM - TIMER HOMING CAM
 TPCAM - TIMER PROGRAM CAM
 HCAM - VALVE HOMING CAM
 SCAM - VALVE STEP CAM
 BVCAM - BRINE VALVE CAM

NOTE:

1. TWO TANK INTERLOCKED, SINGLE REMOTE METER, SERIES REGENERATION.
2. BOTH TANKS NORMALLY IN SERVICE.
3. ONLY ONE TANK IN REGENERATION, THE OTHER REMAINS IN SERVICE.
4. LEAD VALVE REGENERATES FIRST, FOLLOWED IMMEDIATELY BY LAG VALVE.
5. WITH 24V VALVES THE POWER CORD IS REPLACED WITH BLUE AND WHITE WIRES (WIRE BLUE TO TB1 #6, WHITE TO TB1 #1).
6. VALVE SHOWN IN SERVICE POSITION.

13632-02_REVL

System #7 - Alternating Regeneration

24V / 120V / 3-Way Solenoid Output Valve Wiring

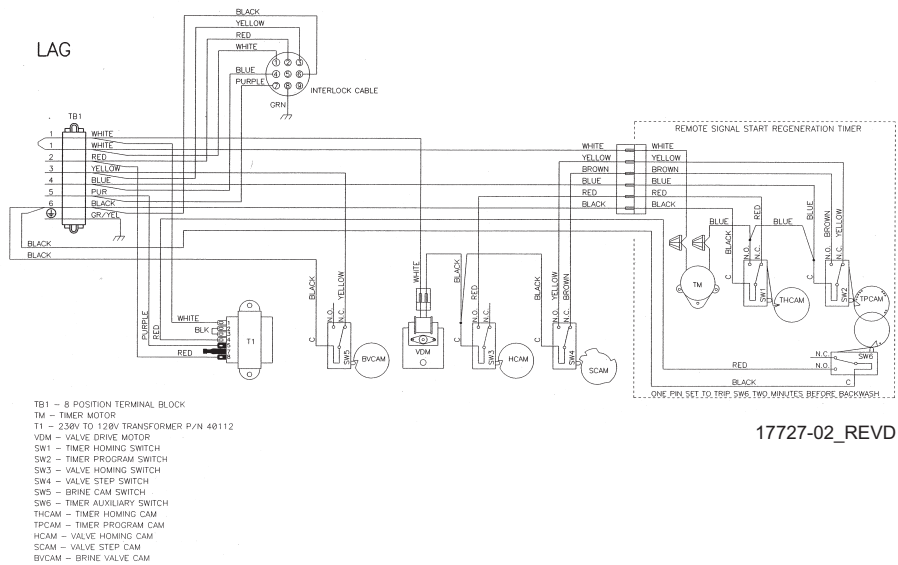
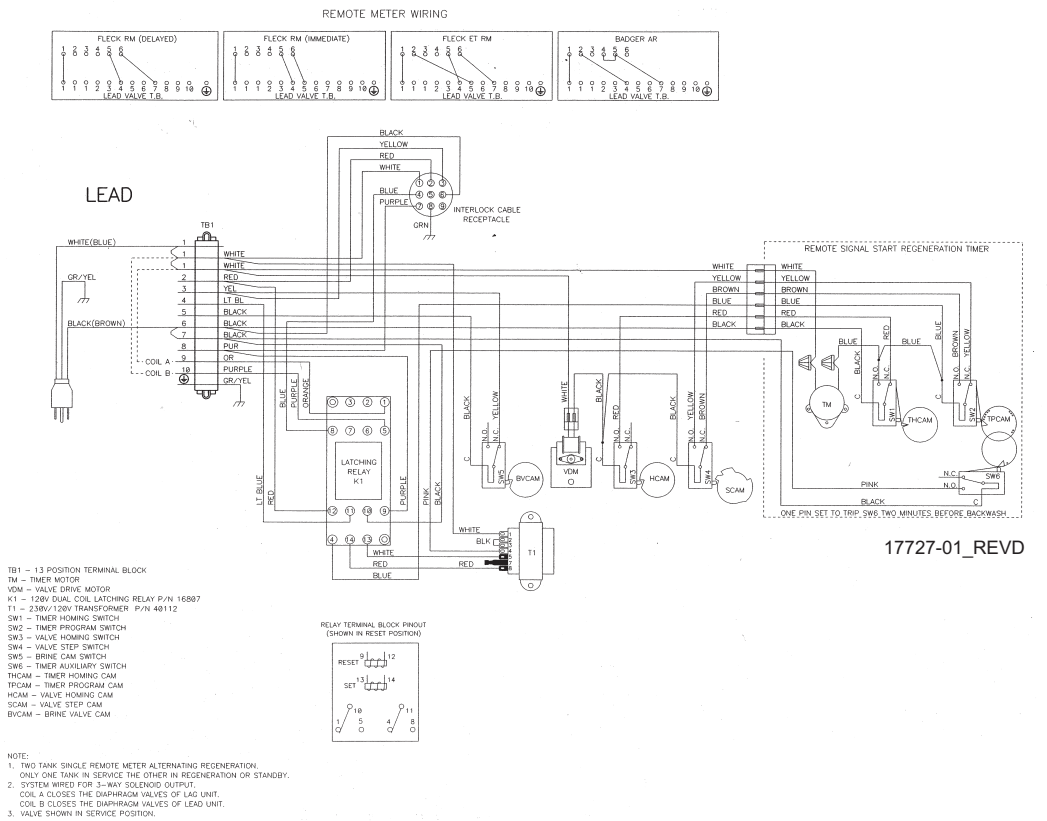

Service Assemblies

24 Hour Gear Assemblies

- 19205 Gear Assy, 24 Hour, Silver, 5600,
12 A.M.
- 60519-02 Gear Assy, 3200 24 Hour 2 Times/
Day, w/Silver Label
- 60519-03 Gear Assy, 3200, 24 Hour 3
Times/Day, w/Silver Label
- 60519-04 Gear Assy, 3200, 24 Hour
4 Times/Day, w/Silver Label
- 60519-06 Gear Assy, 3200, 24 Hour (12:00)
6 Times/Day, w/Silver Label

Adapters

- 61415 Adapter Assy, Sidemount
2850/2900/2930
- 61415NP Adapter Assy, Sidemount,
NP 2850/2900/2930
- 61415-20 Adapter Assy, Sidemount,
BSP/MTC 2850/2900/2930
- 61415-20NP Adapter Assy, Sidemount,
BSP/NP 2850/2900/2930

Air Checks

- 60002-34 Air Check, #500, 34" Long
- 60003-34 Air Check, #500, HW, 34" Tube
- 60009-01 Air Check, #900, Commercial,
HW Less Fittings

Auxiliary Micro Switch

- 60320-02 Switch Kit, 3200/9000 Timer
Auxiliary
- 60320-07 Switch Assy, 2850, Aux w/Self
Tapping Screws
- 60320-12 Switch Assy, 1500 through 2850

Brine Line Flow Control (BLFC)

- 60020-25 BLFC, .25 GPM, 1600
- 60020-50 BLFC, .50 GPM, 1600
- 60020-100 BLFC, 1.0 GPM, 1600
- 60011-090 Brine Valve, 1650, Short Stem
- 60010-25 BLFC, 1650, .25 GPM, Plastic
- 60010-50 BLFC, 1650, .50 GPM, Plastic
- 60010-100 BLFC, 1650, 1.0 GPM, Plastic

Brine Valves

- 60011 Brine Valve, 1650, Less BLFC
- 60029 Brine Valve, 1600, Short Stem
Brass, Std O-rings
- 60029HW Brine Valve, 1600, Short Stem
Hot Water

- 60034-xx 1700 Brine Valve Assy
(Specify flow control 1.0 - 5.0)
- 60604-xx Model 1710 Brine Valve Assy
(Specify flow control 1.0 - 5.0)

Cam Assemblies

- 60160-15 Drive Cam Assy, STF, Blue

Covers

- 60219-xx Environmental
- 60232-xx Designer 2 Piece
- 60232-110 Cover, Designer, 1 Pc Black

Drain Line Flow Controls

- 60366-xx 1" FNPT x 3/4" FNPT (Specify
flow control .6 - 7.0)
- 60701-xx 1" FNPT x 1" FNPT (Specify flow
control 8.0 - 25.0)
- 60702-xx 1" FNPT x 1" MNPT (Specify flow
control 8.0 - 25.0)
- 60708-xx 1" FNPT x 3/4" FNPT (Specify flow
control 8.0 - 25.0)
- 60721-xx 1" FNPT x 1" FNPT (Specify flow
control .6 - 7.0)

Drive Assemblies

- 60050-21 Drive Assy, 2750, STF, 120V
Softener

Injector Assemblies (Complete)

- 60381-xx 1700 Injector Assy (Specify size of
Injector)
- 60480-xx 1600 - 3/8" Brine (Specify size
of injector)
- 60481-xx 1600 Brass - 3/8" Brine (Specify
size of injector)
- 60483-xx 1700 - 1/2" Brine (Specify size of
Injector)

Meters

- 60613 Meter Assy, 2750, Electronic 1"
- 60610-01 Meter, 2850/9500, 1 1/2" Std
- 60610-02 Meter, 2850/9500, 1 1/2" Ext
- 60391 Meter Assy, 2750
- 60392 Meter Assy, 2750, 1" Ext
- 60614 Meter Assy, 2850/9500, Electronic
1 1/2" Meter, Brass

Service Assemblies

- 61560-01 Meter Assy, In-Line, w/1" NPT
Plstc Connector
- 61560-07 Meter Assy, In-Line, w/1" NPT
Brass Connector
- 61560-09 Meter Assy, In-Line, w/ 1 1/2" NPT
Brass Connector

Piston Assemblies

- 60105 Piston Assy, 2850
- 60105-001 Piston Assy., 2850, 560CD
- 60105-01 Piston Assy., 2850, Hot Water
- 60114-00 Piston Assy, Filter, 2850
Conversion, NHWBP
- 60114-01 Piston Assy, 2850, NHWBP
- 60114-02 Piston Assy, 2850, 1600
Conversion, NHWBP
- 60114-03 Piston Assy, 2850, 1700
Conversion, NHWBP

Program Wheel Assemblies

- 60405-20 Program Wheel, w/3/4" Ext Label
..... 1 1/2" Std Set @ 100
- 60405-30 Program Wheel, w/1" Std Label
..... Set @ 50
- 60405-40 Program Wheel, w/1" Ext Label
- 60405-70 Program Wheel, w/1" Ext Label

Safety Brine Valves

- 60014 Safety Brine Valve Assy, 2310
- 60038 Safety Brine Valve, 2350
- 60028-30 Float Assy, 2350, 30", White
- 60026-30SAN Float Assy, 2350, 30" HW
- 60027-FFA Safety Brine Valve Body, 2300
Fitting Facing Arm
- 60027-FFS Safety Brine Valve Body
Fitting Facing Stud
- 60028-30 Float Assy, 2300, 30", Blue/White
- 60068-30 Float Assy, 2310, w/30" Rod

Sales and Service Aids

- 40726 Literature, 2850 Spec Sheet
- 16510 Literature, 2850 S/Manual
- 40717 Literature, Catalog Assy, PWT
Residential/Commercial

Seal & Spacer Kits

- 60129 Seal & Spacer Kit, 2850
- 60129-20 Seal & Spacer Kit, 2850, Natural
- 60129-30 Seal & Spacer Kit, 2850

Service Equipment

- 16174 Silicone, 2 oz. Tube
- 16586-8 Silicone, Dow #7 8 Lb
- 16516 Stuffer Assy, 2850/9500
- 17623 Puller Tool Assy, 2850/9500
- 60460 Meter Checker Kit, Std
- 60461 Meter Checker Kit, Ext

Service Valve Operator Assemblies (SVO)

- 60150 SVO Assy, 1600 O/S
- 60150-01 SVO Assy, 1600 N/S

Skipper Wheel Assemblies

- 14860 Skipper Wheel Assy, 7 Day
- 14381 Skipper Wheel Assy, 12 Day

