

Model 3900

Service Manual



Distributed By:

APPLIED
MEMBRANES INC.®

IMPORTANT: Fill in Pertinent Information on Page 3 for Future Reference

2325 Cousteau Ct. Vista, CA 92081 ☎ (760) 727-3711 📠 (760) 727-4427
🌐 www.appliedmembranes.com ✉ sales@appliedmembranes.com

Table of Contents

Installation & Start-Up Checklist.....	3
Installation Instructions.....	4
3200 Timer Setting Procedure.....	5
3210 & 3220 Timer Settings.....	6
3200, 3210, 3220 & 3230 Regeneration Cycle Setting Procedures.....	7
3200 Time Clock Timer Assembly.....	8
3210 Meter Delayed Timer Assembly.....	10
3220 Meter Immediate Timer Assembly.....	12
3230 Remote Start Timer Assembly.....	14
Control Drive Assembly Upper.....	16
Adapter Control Drive Lower Powerhead.....	18
Control Valve.....	20
1800 Brine System.....	22
3" Meter Assembly.....	24
2350 Safety Brine Valve Assembly.....	25
Troubleshooting.....	26
Water Conditioner Flow Diagrams.....	28
Flow Data & Injector Draw Rates.....	30
Dimensional Drawing 3900 Top Mount.....	31
Dimensional Drawing 3900 Side Mount.....	32
Typical Installations.....	33
System #4 – Valve Wiring.....	35
System #4 With Remote Meter – Valve Wiring.....	36
System #5 – Valve Wiring.....	37
System #6 – Valve Wiring.....	38
System #7 – Valve Wiring.....	39
System #7 Multivalve – Valve Wiring.....	40
Service Assemblies.....	41



IMPORTANT PLEASE READ:

- The information, specifications and illustrations in this manual are based on the latest information available at the time of printing. The manufacturer reserves the right to make changes at any time without notice.
- This product should be installed by a plumbing professional.
- This unit is designed to be installed on potable water systems only.
- This product must be installed in compliance with all state and municipal plumbing and electrical codes. Permits may be required at the time of installation.
- Do not install the unit where temperatures may drop below 34°F (0°C) or above 104°F (40°C).
- Do not place the unit in direct sunlight.
- Do not strike any of the components.
- Warranty of this product extends to manufacturing defects of the vessel and controller, not the membrane. Misapplication of this product may result in failure to properly condition water, or damage to product.
- A prefilter should be used on installations in which free solids are present.
- In some applications local municipalities treat water with Chloramines. High Chloramine levels may damage system components.
- Correct and constant voltage must be supplied to the controller to maintain proper function.

Installation & Start-Up Checklist

Job Number: _____

Model Number: _____

Water Hardness: _____ ppm or gpg

Capacity Per Unit: _____

Mineral Tank Size: _____ Diameter: _____ Height: _____

Salt Setting per Regeneration: _____

1. Type of Timer:

- A. 7 Day or 12 Day B. Meter Initiated

2. Downflow: Upflow Upflow Variable

3. Meter Size:

- A. 3/4" Std Range (125 - 2,100 gallon setting)
B. 3/4" Ext Range (625 - 10,625 gallon setting)
C. 1" Std Range (310 - 5,270 gallon setting)
D. 1" Ext Range (1,150 - 26,350 gallon setting)
E. 1-1/2" Std Range (625 - 10,625 gallon setting)
F. 1-1/2" Ext Range (3,125 - 53,125 gallon setting)
G. 2" Std Range (1,250 - 21,250 gallon setting)
H. 2" Ext Range (6,250 - 106,250 gallon setting)
I. 3" Std Range (3,750 - 63,750 gallon setting)
J. 3" Ext Range (18,750 - 318,750 gallon setting)
K. Electronic _____ Pulse Count _____ Meter Size

4. System Type:

- A. System #4: 1 Tank, 1 Meter, Immediate, or Delayed Regeneration
B. System #4: Time Clock
C. System #4: Twin Tank
D. System #5: 2-5 Tanks, 2 Meters, Interlock
E. System #6: 2-5 Tanks, 1 Meter, Series Regeneration
F. System #7: 2-5 Tanks, 1 Meter, Alternating
G. System #9: Electronic Only, 2-4 Tanks, Meter per Valve, Alternating
H. System #14: Electronic Only, 2-4 Tanks, Meter per Valve. Brings units on and offline based on flow.

5. Timer Program Settings:

- A. Backwash: _____ Minutes
B. Brine and Slow Rinse: _____ Minutes
C. Rapid Rinse: _____ Minutes
D. Brine Tank Refill: _____ Minutes
E. Pause Time: _____ Minutes
F. Second Backwash: _____ Minutes

6. Drain Line Flow Control: _____ gpm

7. Brine Line Flow Controller: _____ gpm

8. Injector Size#: _____

9. Piston Type:

- A. Hard Water Bypass
B. No Hard Water Bypass

Installation Instructions

WATER PRESSURE: A minimum of 20 pounds (1.4 bar) of water pressure is required for regeneration valve to operate effectively.

ELECTRICAL FACILITIES: An uninterrupted alternating current (A/C) supply is required. Note: Other voltages are available. Please make sure your voltage supply is compatible with your unit before installation.

EXISTING PLUMBING: Condition of existing plumbing should be free from lime and iron buildup. Piping that is built up heavily with lime and/or iron should be replaced. If piping is clogged with iron, a separate iron filter unit should be installed ahead of the water softener.

LOCATION OF SOFTENER AND DRAIN: The softener should be located close to a drain to prevent air breaks and back flow.

BY-PASS VALVES: Always provide for the installation of a by-pass valve if unit is not equipped with one.

CAUTION: Water pressure is not to exceed 125 psi (8.6 bar), water temperature is not to exceed 110°F (43°C), and the unit cannot be subjected to freezing conditions.

Installation Instructions

1. Place the softener tank where you want to install the unit making sure the unit is level and on a firm base.
2. During cold weather, the installer should warm the valve to room temperature before operating.
3. All plumbing should be done in accordance with local plumbing codes. The pipe size for residential drain line should be a minimum of 1/2" (13 mm). Backwash flow rates in excess of 7 gpm (26.5 Lpm) or length in excess of 20' (6 m) require 3/4" (19 mm) drain line. Commercial drain lines should be the same size as the drain line flow control.
4. Refer to the dimensional drawing for cutting height of the distributor tube. If there is no dimensional drawing, cut the distributor tube flush with the top of the tank.
5. Lubricate the distributor O-ring seal and tank O-ring seal. Place the main control valve on tank. Note: Only use silicone lubricant.
6. Solder joints near the drain must be done prior to connecting the Drain Line Flow Control fitting (DLFC). Leave at least 6" (15 cm) between the DLFC and solder joints when soldering pipes that are connected on the DLFC. Failure to do this could cause interior damage to the DLFC.
7. Teflon tape is the only sealant to be used on the drain fitting. The drain from twin tank units may be run through a common line.
8. Make sure that the floor is clean beneath the salt storage tank and that it is level.
9. Place approximately 1" (25 mm) of water above the grid plate. If a grid is not utilized, fill to the top of the air check (Figure 1) in the salt tank. Do not add salt to the brine tank at this time.
10. On units with a bypass, place in by-pass position. Turn on the main water supply. Open a cold soft water tap nearby and let run a few minutes or until the system is free from foreign material (usually solder) that may have resulted from the installation. Once clean, close the water tap.
11. Slowly place the bypass in service position and let water flow into the mineral tank. When water flow stops, slowly open a cold water tap nearby and let run until the air is purged from the unit.
12. Plug unit into an electrical outlet. Note: All electrical connections must be connected according to local codes. Be certain the outlet is uninterrupted.

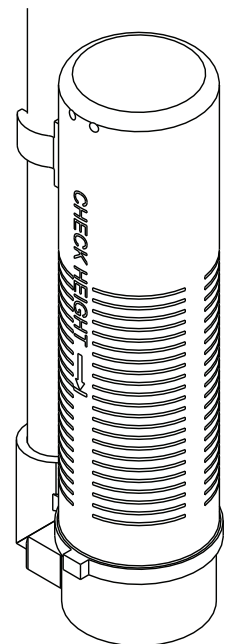

60002-34REVC

Figure 1 Residential Air Check Valve

	<p>CAUTION</p> <ul style="list-style-type: none">• Do not exceed 125 psi (8.6 bar) water pressure.• Do not exceed 110°F (43°C) water temperature.• Do not subject unit to freezing conditions.
---	---

3200 Timer Setting Procedure

How To Set Days On Which Water Conditioner Is To Regenerate (Figure 2):

Rotate the skipper wheel until the number "1" is at the red pointer. Set the days that regeneration is to occur by sliding tabs on the skipper wheel outward to expose trip fingers. Each tab is one day. Finger at red pointer is tonight. Moving clockwise from the red pointer, extend or retract fingers to obtain the desired regeneration schedule.

How To Set The Time Of Day:

1. Press and hold the red button in to disengage the drive gear.
2. Turn the large gear until the actual time of day is at the time of day pointer.
3. Release the red button to again engage the drive gear.

How To Manually Regenerate Your Water Conditioner At Any Time:

1. Turn the manual regeneration knob clockwise.
2. This slight movement of the manual regeneration knob engages the program wheel and starts the regeneration program.
3. The black center knob will make one revolution within the following three hours and stop in the position shown in the drawing.
4. Even though it takes three hours for this center knob to complete one revolution, the regeneration cycle of your unit might be set for only one half of this time.
5. In any event, conditioned water may be drawn after rinse water stops flowing from the water conditioner drain line.

How to Adjust Regeneration Time:

1. Disconnect the power source.
2. Locate the three screws behind the manual regeneration knob by pushing the red button in and rotating the 24 hour dial until each screw appears in the cut out portion of the manual regeneration knob.
3. Loosen each screw slightly to release the pressure on the time plate from the 24 hour gear.
4. Locate the regeneration time pointer on the inside of the 24 hour dial in the cut out.
5. Turn the time plate so the desired regeneration time aligns next to the raised arrow.
6. Push the red button in and rotate the 24 hour dial. Tighten each of the three screws.
7. Push the red button and locate the pointer one more time to ensure the desired regeneration time is correct.
8. Reset the time of day and restore power to the unit.

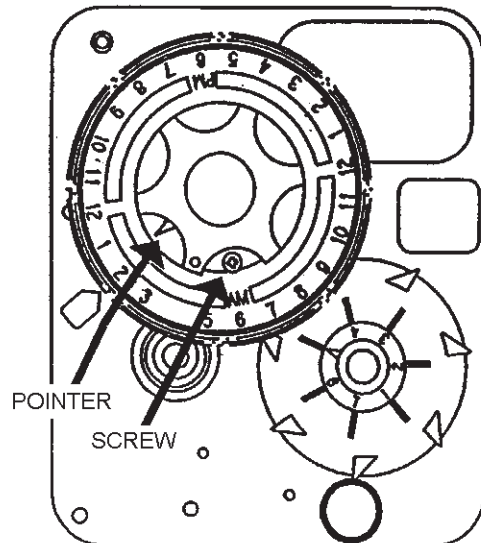
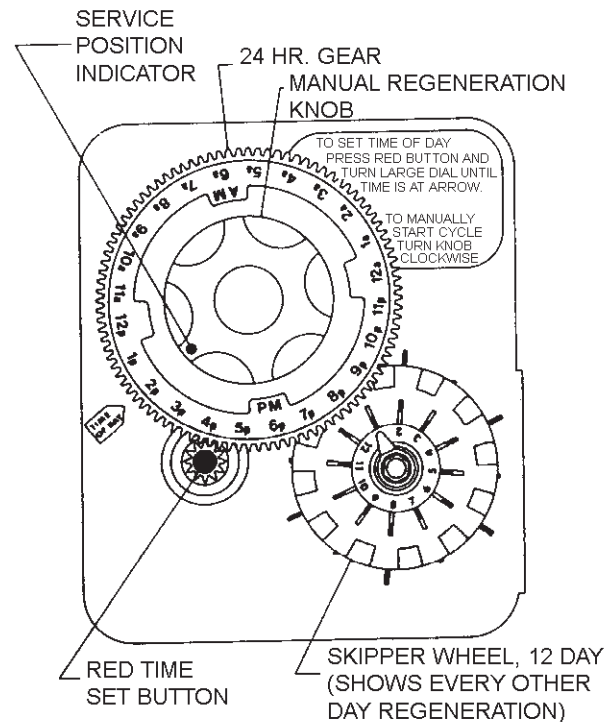

3200 ADJUSTABLE REGENERATION TIMER

IMPORTANT!
SALT LEVEL MUST ALWAYS BE ABOVE
WATER LEVEL IN BRINE TANK

61502_3200REVA

Figure 2

3210 & 3220 Timer Settings

Typical Programming Procedure

Calculate the gallon capacity of the system, subtract the necessary reserve requirement and set the gallons available opposite the small white dot on the program wheel gear (Figure 3).

NOTE: Figure 3 shows 8,750 gallon capacity setting. The capacity (gallons) arrow shows zero gallons remaining. The unit will regenerate at the next set regeneration time.

How To Set The Time Of Day:

1. Press and hold the red button in to disengage the drive gear.
2. Turn the large gear until the actual time of day is opposite the time of day pointer.
3. Release the red button to again engage the drive gear.

How To Manually Regenerate Your Water Conditioner At Any Time:

1. Turn the manual regeneration knob clockwise.
2. This slight movement of the manual regeneration knob engages the program wheel and starts the regeneration program.
3. The black center knob will make one revolution within the following three hours and stop in the position shown in the drawing.
4. Even though it takes three hours for this center knob to complete one revolution, the regeneration cycle of your unit might be set for only one half of this time.
5. In any event, conditioned water may be drawn after rinse water stops flowing from the water conditioner drain line.

Immediate Regeneration Timers:

These timers do not have a 24 hour gear. Setting the gallons on the program wheel and manual regeneration procedure are the same as previous instructions. The timer will regenerate as soon as the capacity gallons reaches zero.

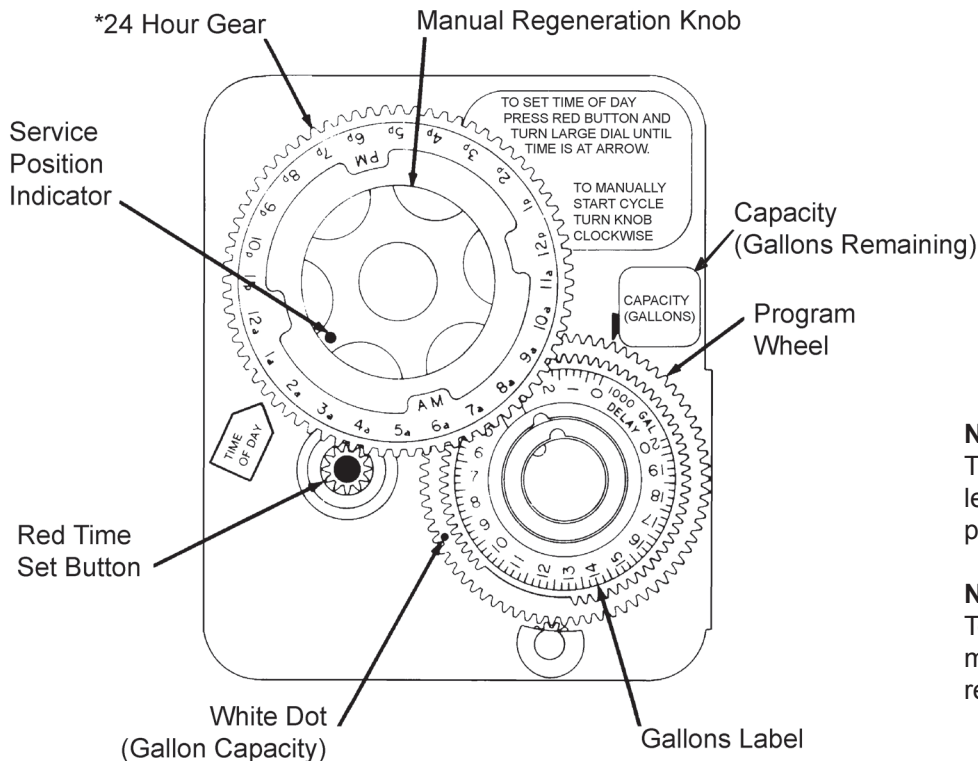

NOTE:

The program wheel to the left may be different than the program wheel on the product.

NOTE:

To set meter capacity rotate manual knob one - 360° revolution to set gallonage.

*Immediate regeneration timers do not have a 24-hour gear. No time of day can be set.

61502_3200REVA

Figure 3

3200 , 3210, 3220 & 3230 Regeneration Cycle Setting Procedure

How To Set The Regeneration Cycle Program:

The regeneration cycle program on your water conditioner has been factory preset, however, portions of the cycle or program may be lengthened or shortened in time to suit local conditions.

3200 & 3210 Series Timers (Figure 4)

1. To expose cycle program wheel, grasp timer in upper left-hand corner and pull, releasing snap retainer and swinging timer to the right.
2. To change the regeneration cycle program, the program wheel must be removed. Grasp program wheel and squeeze protruding lugs toward center, lift program wheel off timer. Switch arms may require movement to facilitate removal.
3. Return timer to closed position engaging snap retainer in back plate. Make certain all electrical wires locate above snap retainer post.

Timer Setting Procedure for 3200 & 3210 Timer

How To Change The Length Of The Backwash Time:

The program wheel as shown in Figure 4 is in the service position. As you look at the numbered side of the program wheel, the group of pins starting at zero determines the length of time your unit will backwash.

EXAMPLE: If there are six pins in this section, the time of backwash will be 12 min. (2 min. per pin). To change the length of backwash time, add or remove pins as required. The number of pins times two equals the backwash time in minutes.

How To Change The Length Of Brine And Rinse Time:

1. The group of holes between the last pin in the backwash section and the second group of pins determines the length of time that your unit will brine and rinse (2 min. per hole).
2. To change the length of brine and rinse time, move the rapid rinse group of pins to give more or fewer holes in the brine and rinse section. Number of holes times two equals brine and rinse time in minutes.

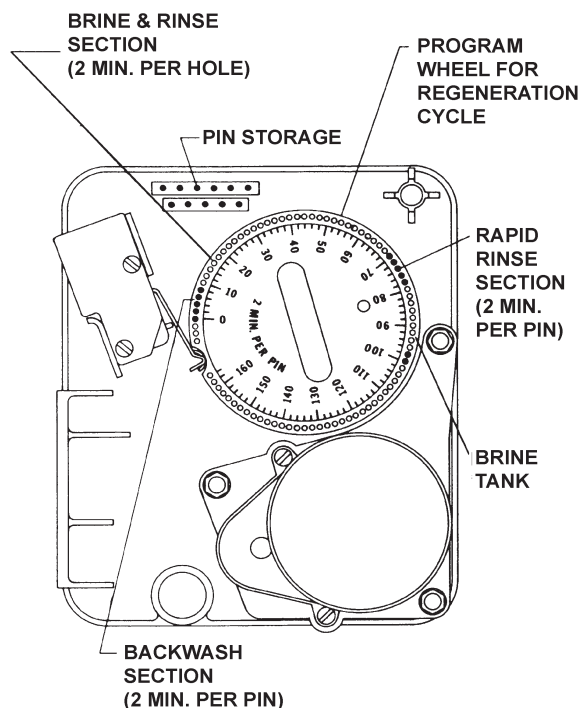

Figure 4

How To Change The Length Of Rapid Rinse:

1. The second group of pins on the program wheel determines the length of time that your water conditioner will rapid rinse (2 min. per pin).
2. To change the length of rapid rinse time, add or remove pins at the higher numbered end of this section as required. The number of pins times two equals the rapid rinse time in minutes.

How To Change The Length Of Brine Tank Refill Time:

1. The second group of holes in the program wheel determines the length of time that your water conditioner will refill the brine tank (2 min. per hole).
2. To change the length of refill time, move the two pins at the end of the second group of holes as required.
3. The regeneration cycle is complete when the outer microswitch is tripped by the two pin set at end of the brine tank refill section.
4. The program wheel, however, will continue to rotate until the inner micro switch drops into the notch on the program wheel.

3200 Time Clock Timer Assembly

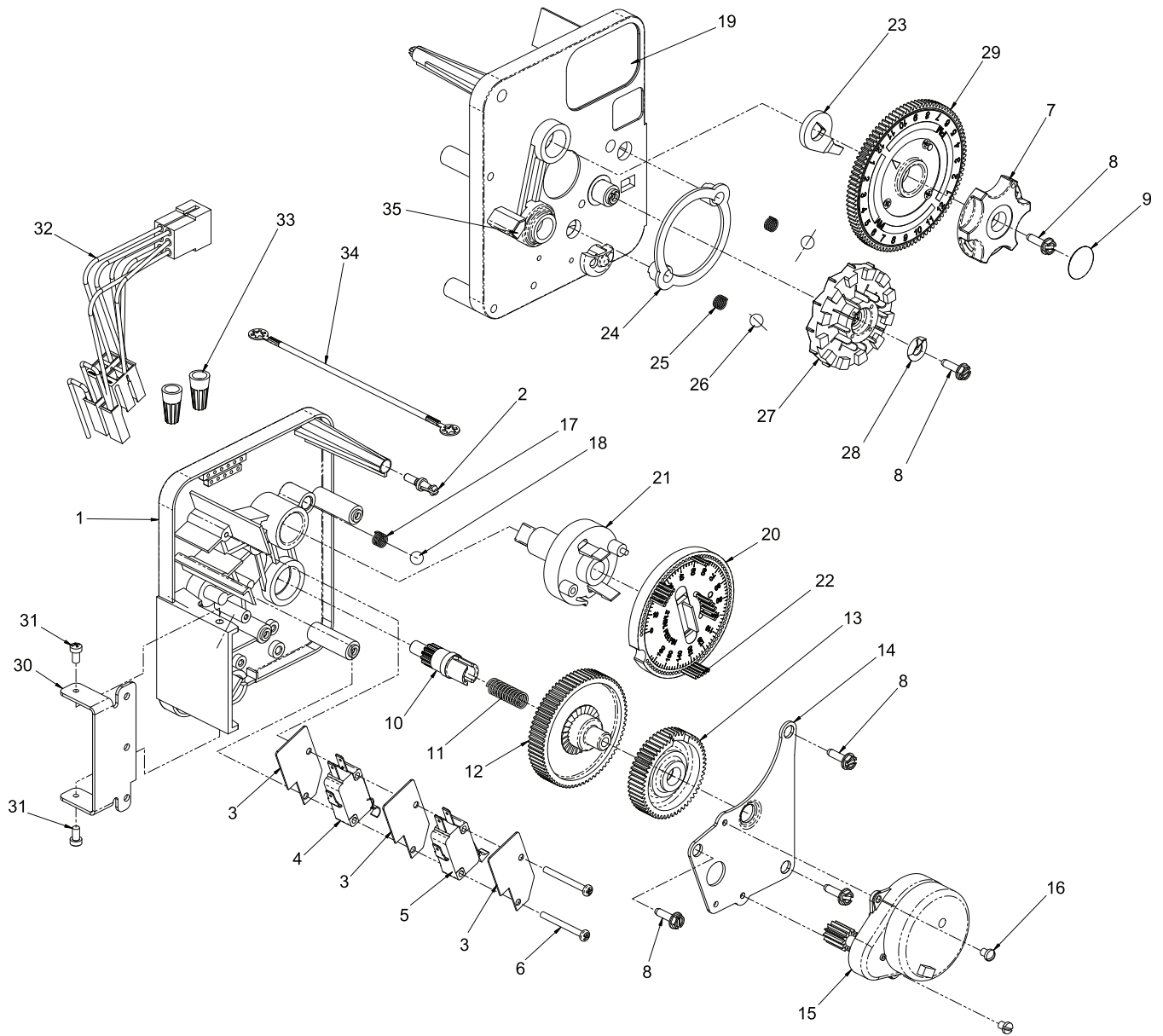

61502-3200_REVA

For Service Assembly Numbers, See the Back of this Manual

3200 Time Clock Timer Assembly

Item No.	Quantity	Part No.	Description
1	1	13870	Housing, Timer, 3200
2	1	14265	Clip, Spring
3	3	14087	Insulator
4	1	10896	Switch, Micro
5	1	15320	Switch, Micro, Timer
6	2	11413	Screw, Pan Hd Mach, 4-40 x 1 1/8
7	1	13886	Knob, 3200
8	5	13296	Screw, Hex Wsh, 6-20 x 1/2
9	1	11999	Label, Button
10	1	13018	Pinion, Idler
11	1	13312	Spring, Idler Shaft
12	1	13017	Gear, Idler
13	1	13164	Gear, Drive
14	1	13887	Plate, Motor Mounting
15	1	18743-1	Motor, 120V, 60Hz, 1/30 rpm, 5600
		19659-1	Motor, 24V, 60Hz, 1/30 rpm
16	2	13278	Screw, Sltd Fillister Hd 6-32 x .156
17	1	15424	Spring, Detent, Timer
18	1	15066	Ball, 1/4", Delrin
19	1	15465	Label, Caution
20	1	19210	Program Wheel Assembly
21	1	13911	Gear, Main Drive, Timer
22	17	41754	Pin, Spring, 1/16 x 5/8 Stainless Steel, Timer
23	1	13011	Arm, Cycle Actuator
24	1	13864	Ring, Skipper Wheel
25	2	13311	Spring, Detent, Timer
26	2	13300	Ball, 1/4", Stainless Steel
27	1	14381	Skipper Wheel Assembly, 12 Day
		14860	Skipper Wheel Assembly, 7 Day
28	1	13014	Pointer, Regeneration
29	1	40096-24	Dial, 12 AM Regen Assembly, Black
		40096-02	Dial, 2 AM Regen Assembly, Black
30	1	13881	Bracket, Hinger Timer
31	2	11384	Screw, Phil, 6-32 x 1/4 Zinc
32	1	13902	Harness, 3200
33	2	40422	Nut, Wire, Tan
34	1	15354-01	Wire, Ground, 4"
35	1	14007	Label, Time of Day

For Service Assembly Numbers, See the Back of this Manual

3210 Meter Delayed Timer Assembly

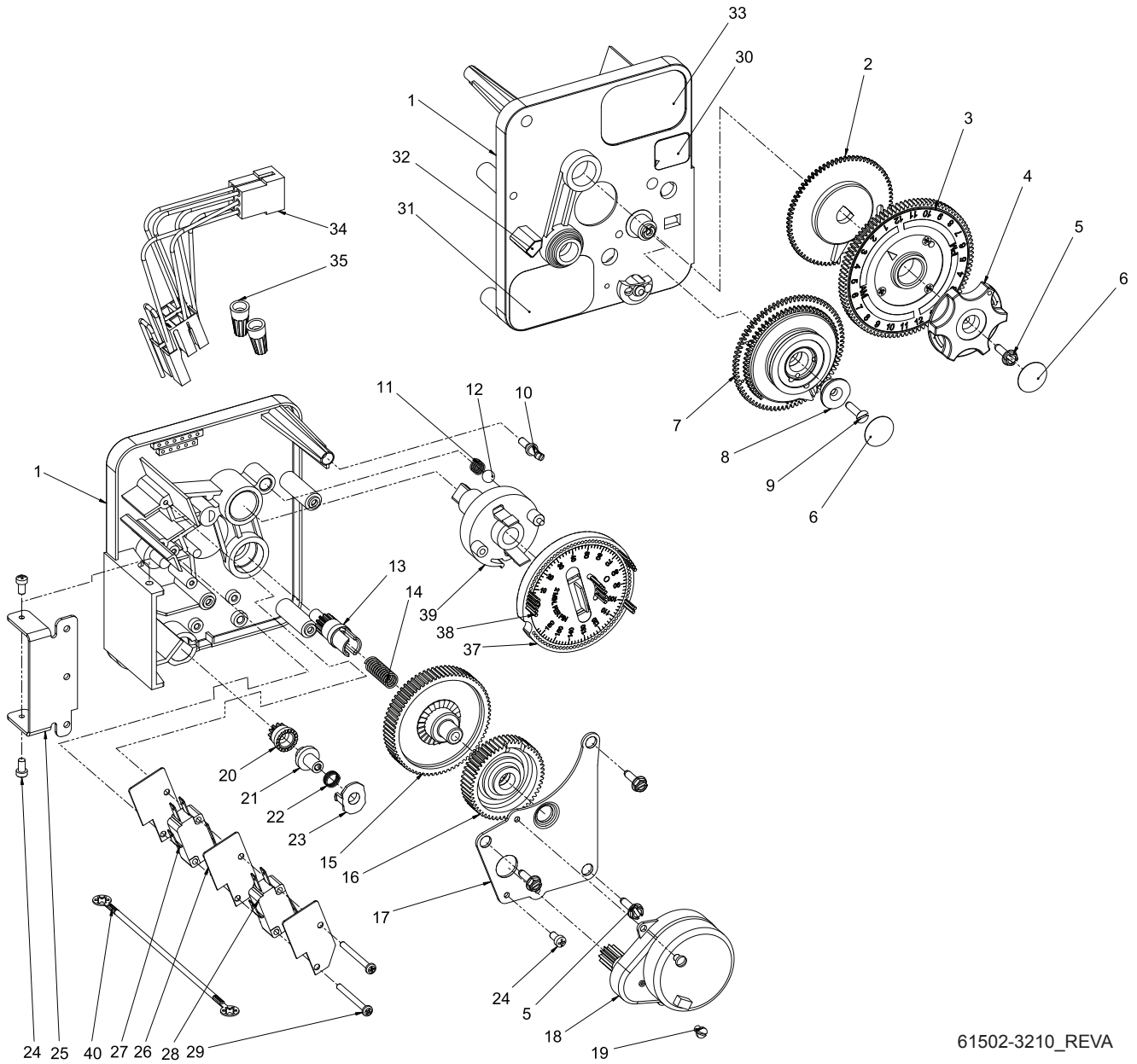

61502-3210_REVA

For Service Assembly Numbers, See the Back of this Manual

3210 Meter Delayed Timer Assembly

Item No.	Quantity	Part No.	Description
1.....	1	13870	Housing, Timer, 3200
2.....	1	13802	Gear, Cycle Actuator
3.....	1	40096-02	Dial 2AM Regen Assembly, Black
4.....	1	13886	Knob, 3200
5.....	4	13296	Screw, Hex Wsh, 6-20 x 1/2
6.....	2	11999	Label, Button
7.....	1	60405-50	Program Wheel, w/2" Std Label, w/People Label Set @ 21
8.....	1	13806	Retainer, Program Wheel
9.....	1	13748	Screw, Flat Head St, 6-20 x 1/2
10.....	1	14265	Clip, Spring
11.....	1	15424	Spring, Detent, Timer
12.....	1	15066	Ball, 1/4" Delrin
13.....	1	13018	Pinion, Idler
14.....	1	13312	Spring, Idler Shaft
15.....	1	13017	Gear, Idler
16.....	1	13164	Gear, Drive
17.....	1	13887	Plate, Motor Mounting
18.....	1	18743-1	Motor, 120V, 60Hz 1/30 rpm, 5600
19.....	1	13278	Screw, Fillister Hd, 6-32 x .156
20.....	1	13830	Pinion, Program Wheel Drive
21.....	1	13831	Clutch, Drive Pinion
22.....	1	14276	Spring, Meter, Clutch
23.....	1	14253	Retainer, Clutch Spring
24.....	3	11384	Screw, Phil, 6-32 x 1/4
25.....	1	13881	Bracket, Hinge Timer
26.....	3	14087	Insulator
27.....	1	10896	Switch, Micro
28.....	1	15320	Switch, Micro, Timer
29.....	2	11413	Screw, Pan Hd Mach, 4-40 x 1 1/8
30.....	1	14198	Label, Indicator
31.....	1	15465	Label, Caution
32.....	1	14007	Label, Time of Day
33.....	1	14045	Label, Instruction
34.....	1	13902	Harness, 3200
35.....	2	40422	Nut, Wire, Tan
36.....	1	15354-01	Wire, Ground, 4"
37.....	1	19210	Program Wheel Assembly
38.....	17	41754	Pin, Spring, 1/16 x 5/8 Stainless Steel, Timer
39.....	1	13911	Gear, Main Drive, Timer
40.....	1	15354-01	Wire, Ground 4"

For Service Assembly Numbers, See the Back of this Manual

3220 Meter Immediate Timer Assembly

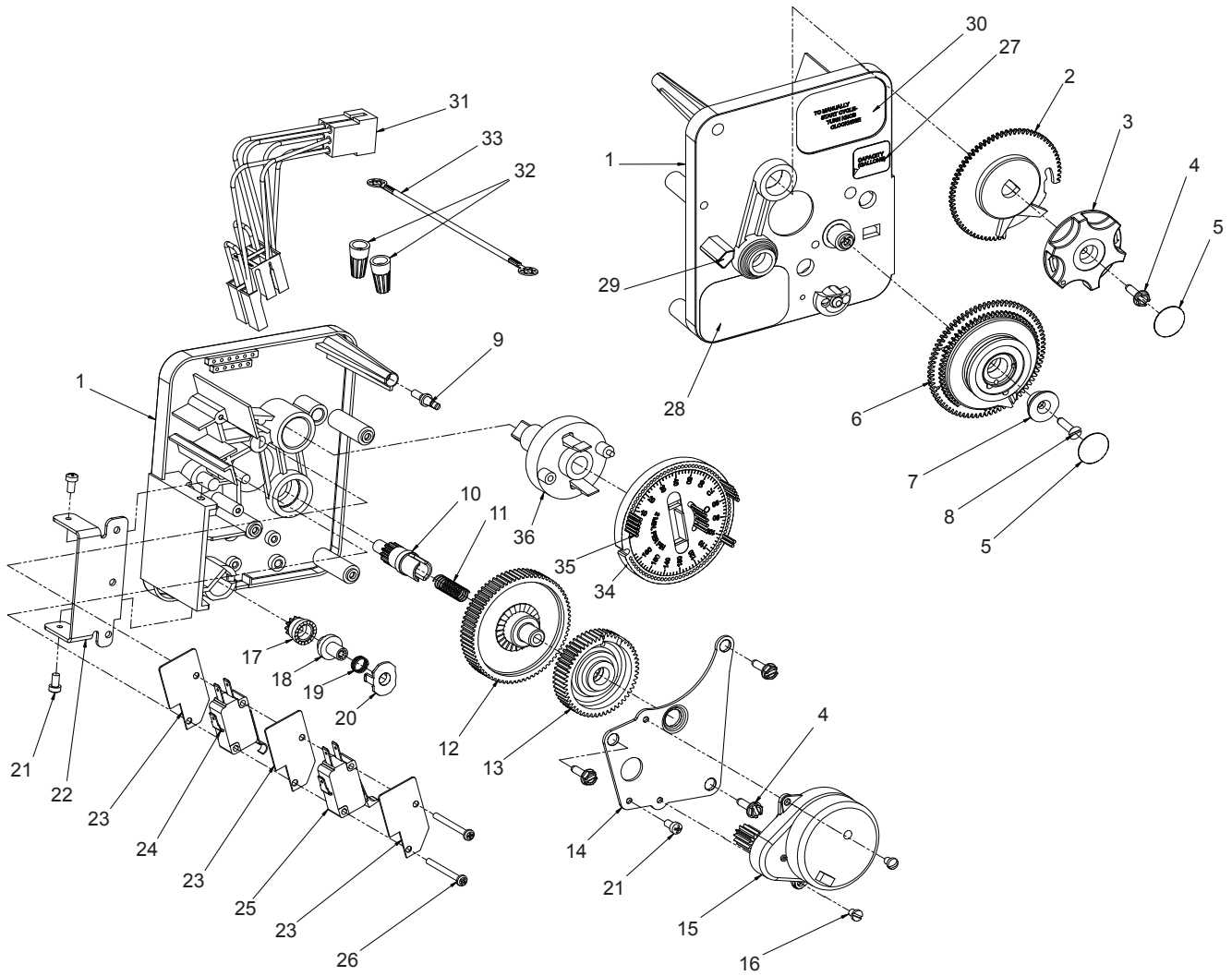

3220 Meter Immediate Timer Assembly

Item No.	Quantity	Part No.	Description
1.....	1	13870.....	Housing, Timer
2.....	1	15431.....	Gear, Cycle Actuator, System #5
3.....	1	13886.....	Knob, 3200
4.....	4	13296.....	Screw, Hex Wsh, 6-20 x 1/2
5.....	2	11999.....	Label, Button
6.....	1	60408-50	Program Wheel, W/2" Std Label
7.....	1	13806.....	Retainer, Program Wheel
8.....	1	13748.....	Screw, Flt Hd St, 6-20 x 1/2
9.....	1	14265.....	Spring Clip
10.....	1	13018.....	Pinion, Idler
11.....	1	18563.....	Idler Shaft Spring
12.....	1	13017.....	Gear, Idler
13.....	1	13164.....	Drive Gear
14.....	1	13887.....	Plate, Motor Mounting
15.....	1	18743-1	Motor, 120V, 60 Hz, 1/30 rpm, 5600
16.....	2	13278.....	Screw, Sltd Fillister Head
17.....	1	14502.....	Pinion, Program Wheel
18.....	1	14501.....	Clutch, Drive Pinion
19.....	1	14276.....	Meter Clutch Spring
20.....	1	14253.....	Retainer, Clutch Spring
21.....	3	11384	Screw, Phil, 6-32 x 1/4 Zinc
22.....	1	13881.....	Bracket, Hinge Timer
23.....	3	14087.....	Insulator
24.....	1	15414-00	Micro Switch
25.....	1	15320.....	Switch, Micro, Timer
26.....	2	11413.....	Screw, Pan Hd Mach, 4-40 x 1-1/8
27.....	1	14198.....	Label, Indicator
28.....	1	15465.....	Label, Caution
29.....	1	14007.....	Label, Time of Day
30.....	1	15148.....	Label, Instruction
31.....	1	40617.....	Harness, 3220
32.....	2	40422.....	Nut, Wire, Tan
33.....	1	15354-01	Wire, Ground, 4"
34.....	1	19210-05	Program Wheel Assembly, 9000/3230
35.....	17	41754.....	Pin, Spring, 1/16 x 5/8 Stainless Steel, Timer
36.....	1	15055.....	Gear, Main Drive

3230 Remote Start Timer Assembly

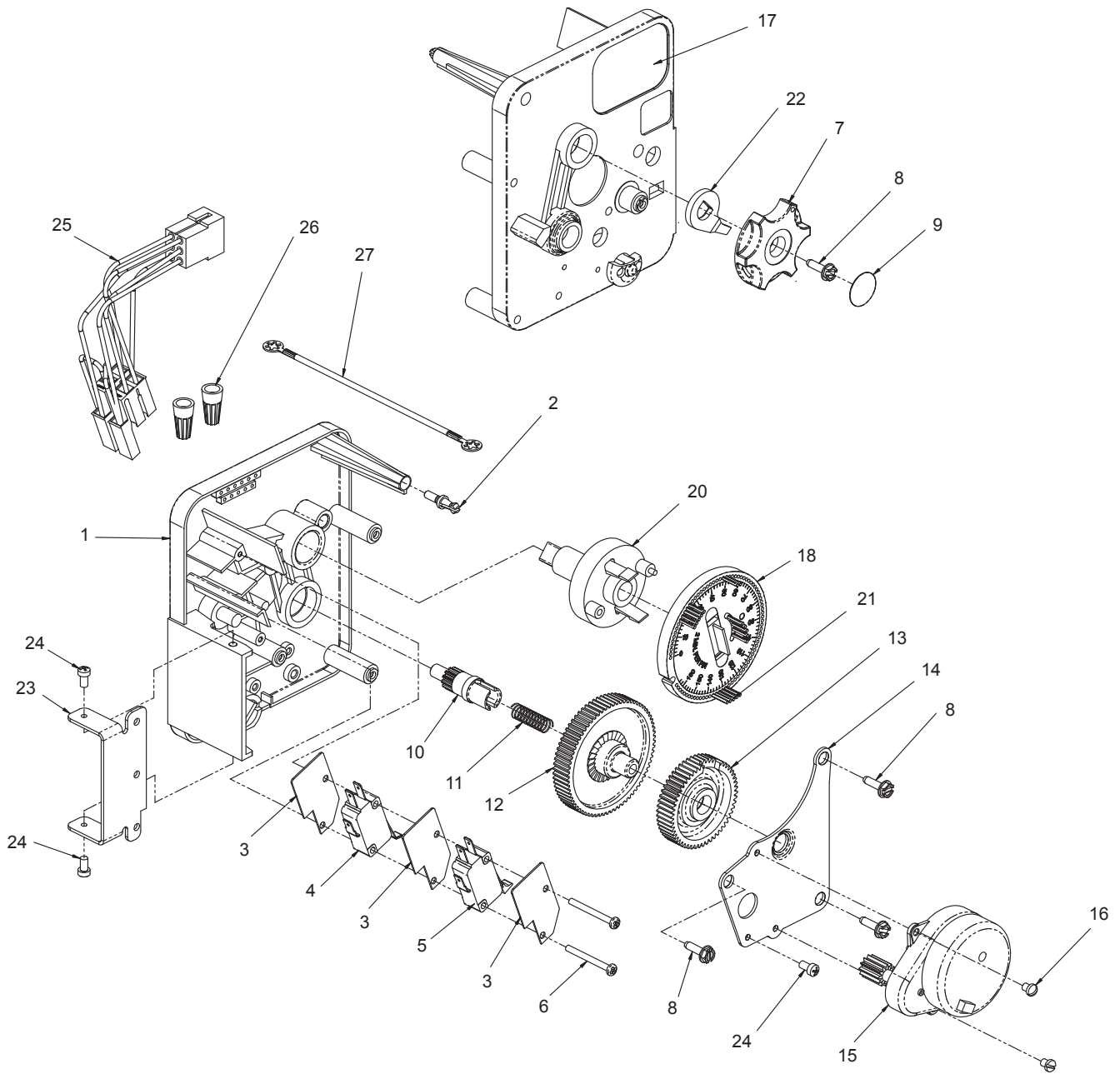

3230 Remote Start Timer Assembly

Item No.	Quantity	Part No.	Description
1	1	13870	Housing, Timer
2	1	14265	Spring Clip
3	3	14087	Insulator
4	1	15314	Micro Switch
5	1	15320	Switch, Micro, Timer
6	2	11413	Screw, Pan Hd Mach, 4-40 x 1-1/8
7	1	13886	Knob, 3200
8	4	13296	Screw, Hex Wsh, 6-20 x 1/2
9	1	11999	Label, Button
10	1	13018	Pinion, Idler
11	1	18563	Idler Shaft Spring
12	1	13017	Gear, Idler
13	1	15055	Drive Gear
14	1	13887	Plate, Motor Mounting
15	1	18743-1	Motor, 120V, 60 Hz, 1/10 rpm
	1	19659-1	Motor, 24V, 60 Hz, 1/30 rpm
16	2	13278	Screw, Slted Fillister Hd
17	1	15313	Label, Caution
18	1	19210-05	Program Wheel Assembly, 3200
20	1	15055	Main Drive Gear
21	17	41754	Pin, Spring, 1/16 x 5/8 Stainless Steel, Timer
22	1	13011	Cycle Actuator Arm
23	1	13881	Bracket, Hinge Timer
24	3	11384	Screw, Phil, 6-32 x 1/4 Zinc
25	1	16336	Harness, 3230R
26	2	40422	Nut, Wire, Tan
27	1	15354-01	Wire, Ground, 4"

Control Drive Assembly Upper

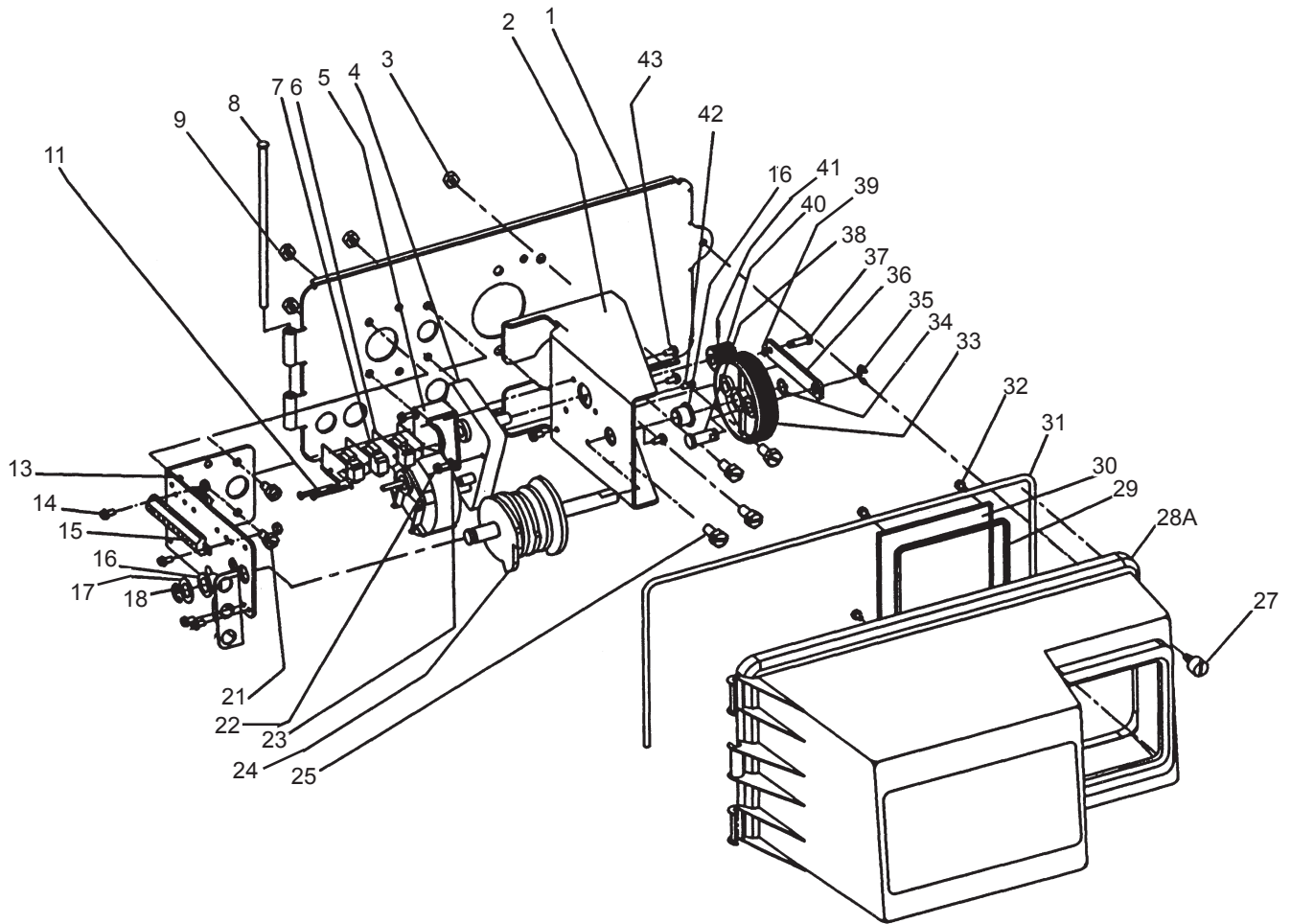

Control Drive Assembly Upper

Item No.	Quantity	Part No.	Description
1	1	19304-04	Back Plate -01, -02
2	1	15120-01	Bracket - Motor Mounting
3	2	16346	Nut - 5/16 - 18
4	1	40392	Drive Motor - 115 V. 50/60 Hz.
		40390	Drive Motor - 220 V. 50/60 Hz.
		42581	Drive Motor - 24 VAC/DC 50/60 Hz.
5	1	17797	Bracket - Switch Mounting
6	4	10302	Insulator - Switch
7	3	10218	Switch
8	1	17845-03	Pin, Hinge
9	4	11235	Nut, 1/4 - 20
11	2	14202-01	Screw - Hex Wsh Mach, 8-32 x 5/16 18-8 Stainless Steel
13	1	16053	Bracket - Brine Side
14	2	40133	Screw - Pan Hd, 4-40 x 1/4
15	1	15226-6	Terminal Block
16	2	16052	Bushing
17	1	16059	Washer
18	1	16051	Retaining Ring - Bowed "E"
21	4	10231	Screw - Hex Head
22	2	17567	Screw - Hex Head
23	2	12288	Washer, Lock, #8 Internal
24	1	16494-05	Cam Assembly - Service After RR
	1	16494-03	Cam Assembly - Service After Brine Refill
25	4	11224	Screw - Hex Head
27	1	18744	Screw
28A	1	60240-02	Cover, Black, Clear Window, Environmental
29	1	18615	Seal, Window
30	1	18745	Window
31	1	18716	Seal, Cover
32	4	19203	Screw
33	1	16046	Drive Gear
34	1	16050	Retaining Ring
35	1	11774	Retaining Ring "E"
36	1	16047	Drive Link
37	1	11709	Pin - Drive Link
38	1	16048	Bearing - Drive Link
39	1	11898	Clip
40	1	16045	Drive Pinion
41	1	11381	Roll Pin
42	1	11080	Screw - Flat Hd.
43	3	10872	Screw - Hex Hd.
44	1		Timer - (not shown)
45	1	40084-12	Power Cord, 120 V., 12 Ft. (not shown)
	1	40085-12	Power Cord, 240 V., 7 Ft. (not shown)
46	1	17967	Strain Relief (not shown)
47	1	40396	Harness (not shown) Enviromental, System 4
48	1	19691	Hole Plug - 3/4 Diameter (not shown)
49	1	19591	Hole Plug - 7/8 Diameter (not shown)
52	1	14924	Strain Relief (not shown)
53	1	15513	Meter Cable (not shown)
54	2	15250	Label - Terminal Strip (not shown)
55	1	16821	Cable Guide Assembly (not shown)

Adapter Control Drive Lower Powerhead

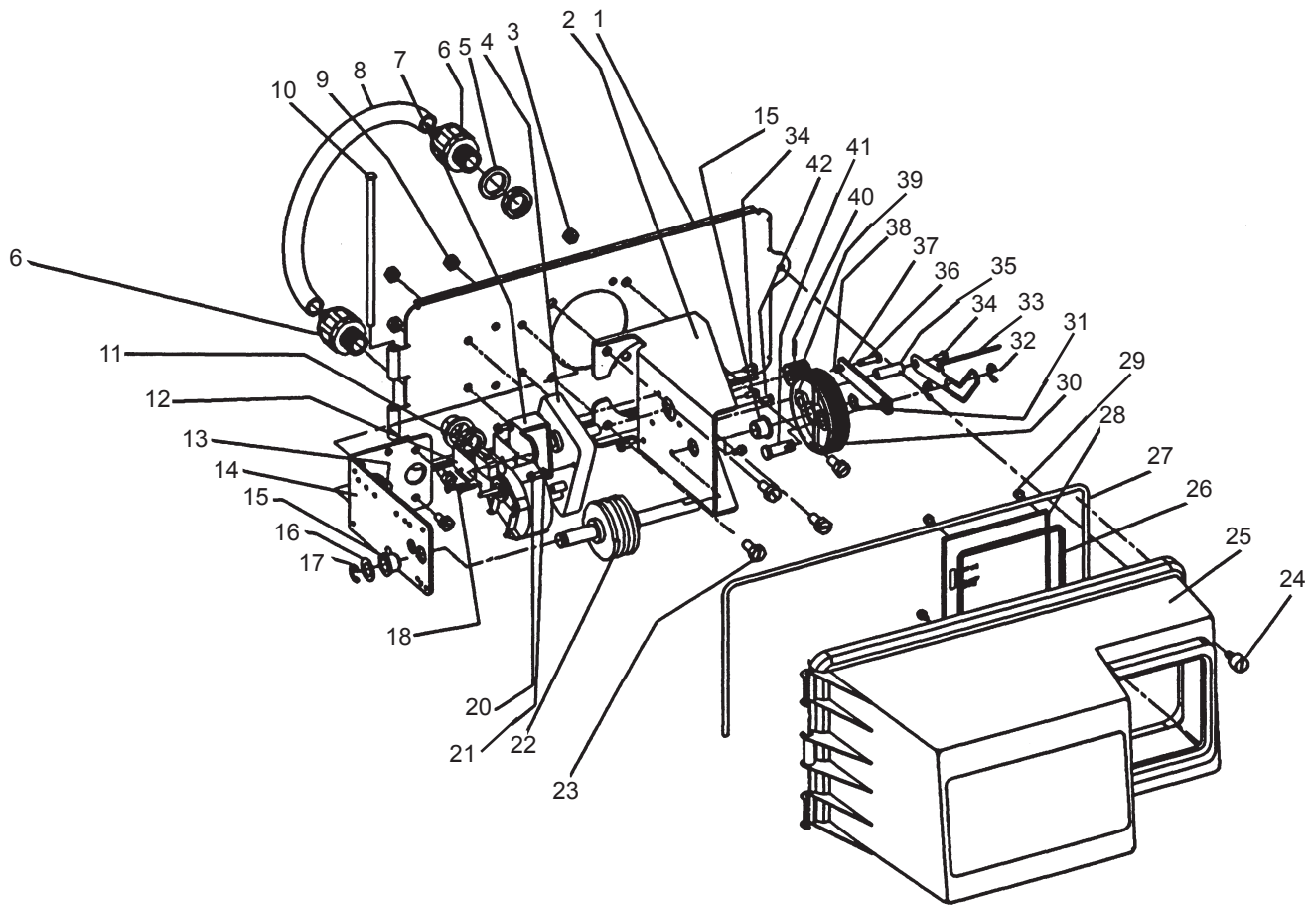

Adapter Control Drive Lower Powerhead

Item No.	Quantity	Part No.	Description
1	1	19305	Back Plate, 3900 Lower, Enviromental
2	1	16086	Bracket - Motor Mounting
3	2	16346	Nut
4	1	40392	Drive Motor - 115 V. 50/60 Hz.
		40390	Drive Motor - 220 V. 50/60 Hz.
		42581	Drive Motor - 24 VAC/DC 50/60 Hz.
5	2	18692	Washer, Sealing
6	2	18691	Connector, Conduit
7	1	17797	Bracket - Switch Mounting
8	1	18693	Conduit, Interdrive
9	4	11235	Nut, 1/4-20
10	1	17845-03	Pin, Hinge
11	1	10218	Switch
12	2	10302	Insulator - Switch
13	4	10231	Screw - Hex Head
14	1	16053	Bracket - Brine Side
15	2	16052	Bushing
16	1	16059	Washer
17	1	16051	Retaining Ring - Bowed "E"
18	2	11805	Screw - Pan Head
20	2	17567	Screw - Hex Head
21	2	12288	Washer, Lock, Internal #8
22	1	16495	Cam Assembly
23	4	11224	Screw - Hex Head
24	1	19813/19856	Screw & Washer, Cover
25	1	60240-22	Cover, Black, Lower, Enviromental
26	1	18615	Seal, Window
27	1	18716	Seal, Cover
28	1	19316	Window, Indicator
29	4	19203	Screw, Window
30	1	16046	Drive Gear
31	1	16050	Retaining Ring
32	2	11774	Retaining Ring - "E"
33	1	19315	Indicator
34	4	10872	Screw - Hex Head
35	1	18726	Space, Indicator
36	1	11709	Pin - Drive Link
37	1	16047	Drive Link
38	1	11898	Clip
39	1	16045	Drive Pinion
40	1	11381	Roll Pin
41	1	16048-01	Bearing - Drive Link
42	2	11080	Screw - Flat Head
43	1	40405	Wire Harness (not shown), Enviromental, System 4, Lower

Control Valve

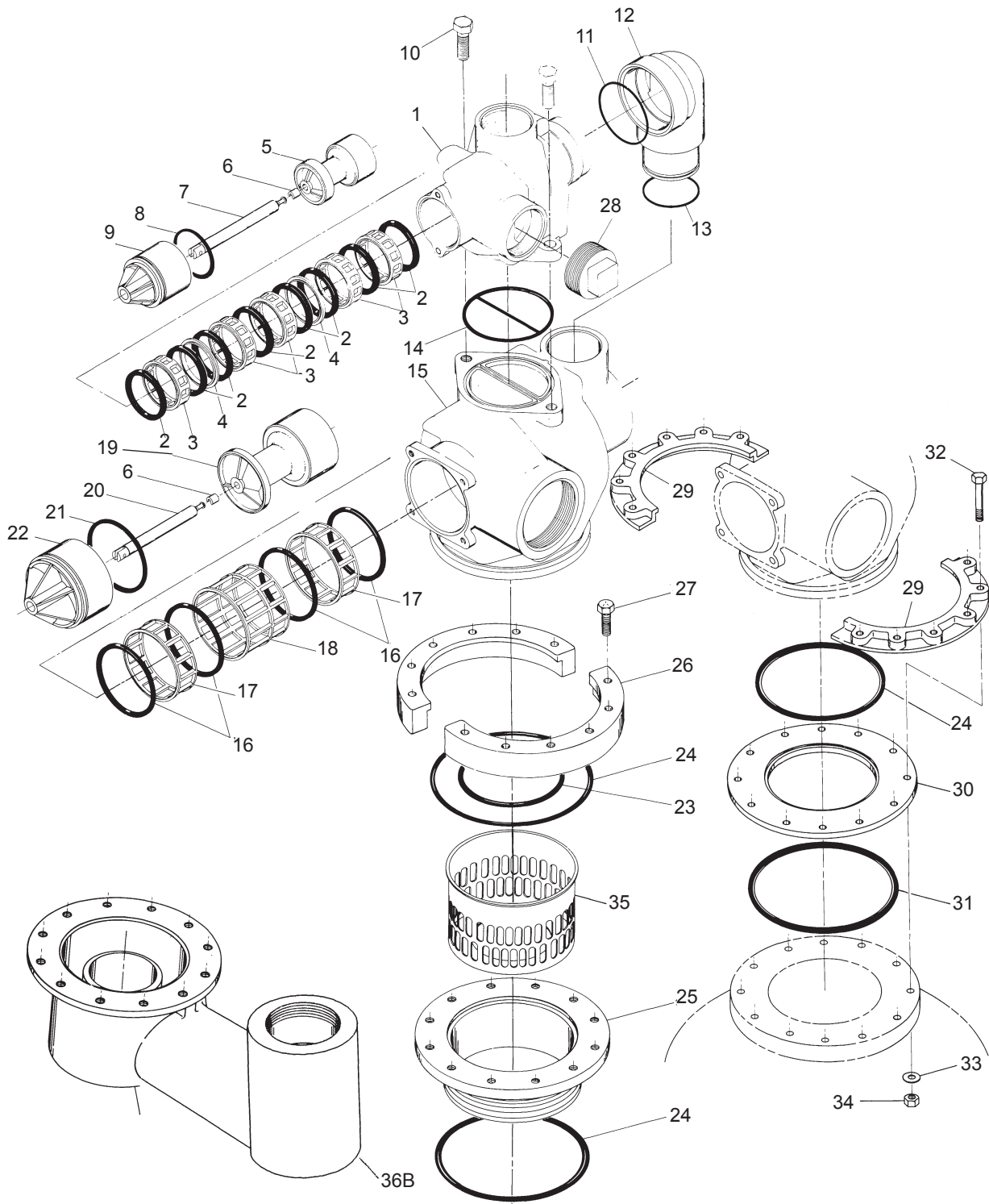

61500-3900

Item No.	Quantity	Part No.	Description
1	1	15114	Valve Body
2	8	11720	Seal
	8	11720-02	Seal, Silicone
3	5	10369	Spacer - Port
4	2	10368	Spacer
5	1	16130	Piston
6	2	14818	Clip - Piston Rod
7	1	15125	Piston Rod
8	1	14922	O-ring -035
9	1	16398-01	End Plug Assembly
10	2	40118	Screw - Hex Head
11	1	16078	O-ring - 149
12	1	16074	Coupling
13	1	16077	O-ring - 140
14	1	15112	Seal
15	1	16067-02	3" Adapter Body
16	4	16068	Seal
	4	41534	Seal, 3900, 558 BP
17	2	16069	Spacer - Narrow
18	1	16070	Spacer - Wide
19	1	16071	Piston
	1	16082	Piston - No Hard Water Bypass
20	1	16072	Piston Rod
21	1	16076	O-ring - 042
22	1	16399-01	End Plug Assy - White
	1	16399-11	End Plug Assy - Black, NHWB-P
23	1	16800	O-ring - 238
24	2	16345	O-ring - 362
25	1	16255	Tank Adapter - 6" -8
26	2	16257	Flange Segment
27	12	11238	Screw - Hex Head
28	1	16088	Pipe Plug - 2" NPT
35	1	16258	Flow Disperser

Options

29	2	16482	Flange Segment
30	1	16483	Flange Ring
31	1	16484	O-Ring -442
32	12	16517	Screw, Park Tank
	12	19592	Screw, Structural Tank
33	12	18619	Washer
34	12	16346	Nut
35	1	19608-20	Disperser (Upper)
36B	1	18584	Adapter, Side Mount

1800 Brine System

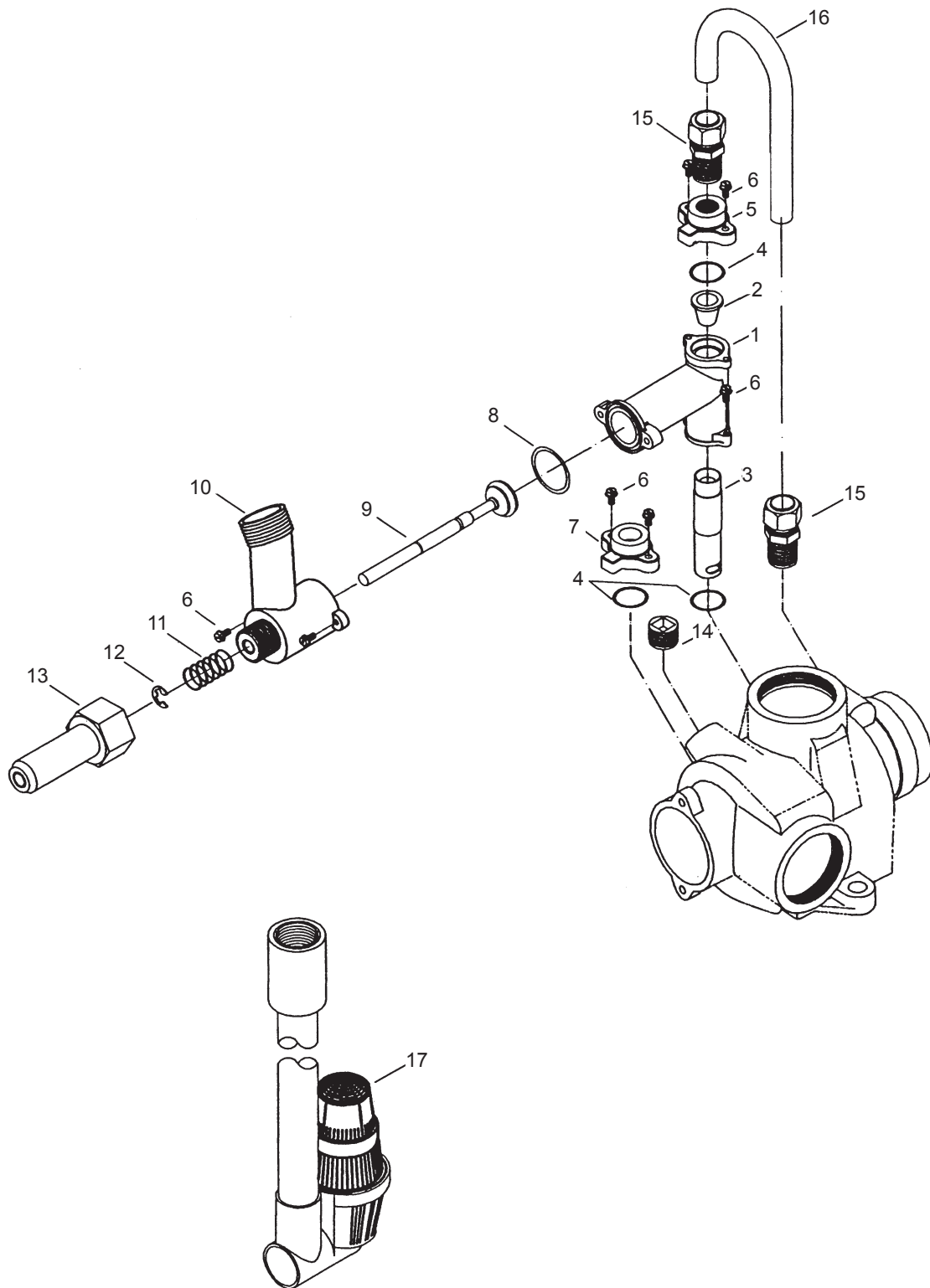

60036-02

1800 Brine System

Item No.	Quantity	Part No.	Description
1	1	16340	Injector Body
2	1	15128-*	Injector Nozzle
3	1	15127-*	Injector Throat
4	3	15246	O-ring - 116
5	1	16341-01	Injector Cover
6	8	12473	Screw - Hex Head
	8	19677	Screw - Hex Head (Metric)
7	1	16341-02	Cover
8	1	19054	O-ring - 124
9	1	16497-01	Brine Stem Assembly
10	1	18713	Brine Valve Body
11	1	11772	Spring
12	1	11774	Retaining Ring
13	1	16498-01	Stem Guide Assembly
14	1	16387	Pipe Plug - 1/2 NPT
15	2	18702	Tube Fitting - Straight
16	1	18703	Brine Tube
17	1	60009	#900 Commercial Air Check
	1	60009-01	#900 Commercial Air Check Hot Water
18	1	Flow Control	- Specify Flow Rate
			- Not Shown See Service Assemblies

*Specific Size

Option Without Brine Valve

1	16605	Retainer Plate
1	16620	Fitting - Brine Tank
1	18879	O-ring, 021

Delete: Items 9 thru 16

Injector Throat

15127-04	#4	Green
15127-05	#5	Red
15127-06	#6	White
15127-07	#7	Blue
15127-08	#8	Yellow
15127-09	#9	Violet
15127-10	#10	Black

Injector Nozzle

	Size	Color
15128-04	#4	Green
15128-05	#5	Red
15128-06	#6	White
15128-07	#7	Blue
15128-08	#8	Yellow
15128-09	#9	Violet
15128-10	#10	Black

3" Meter Assembly

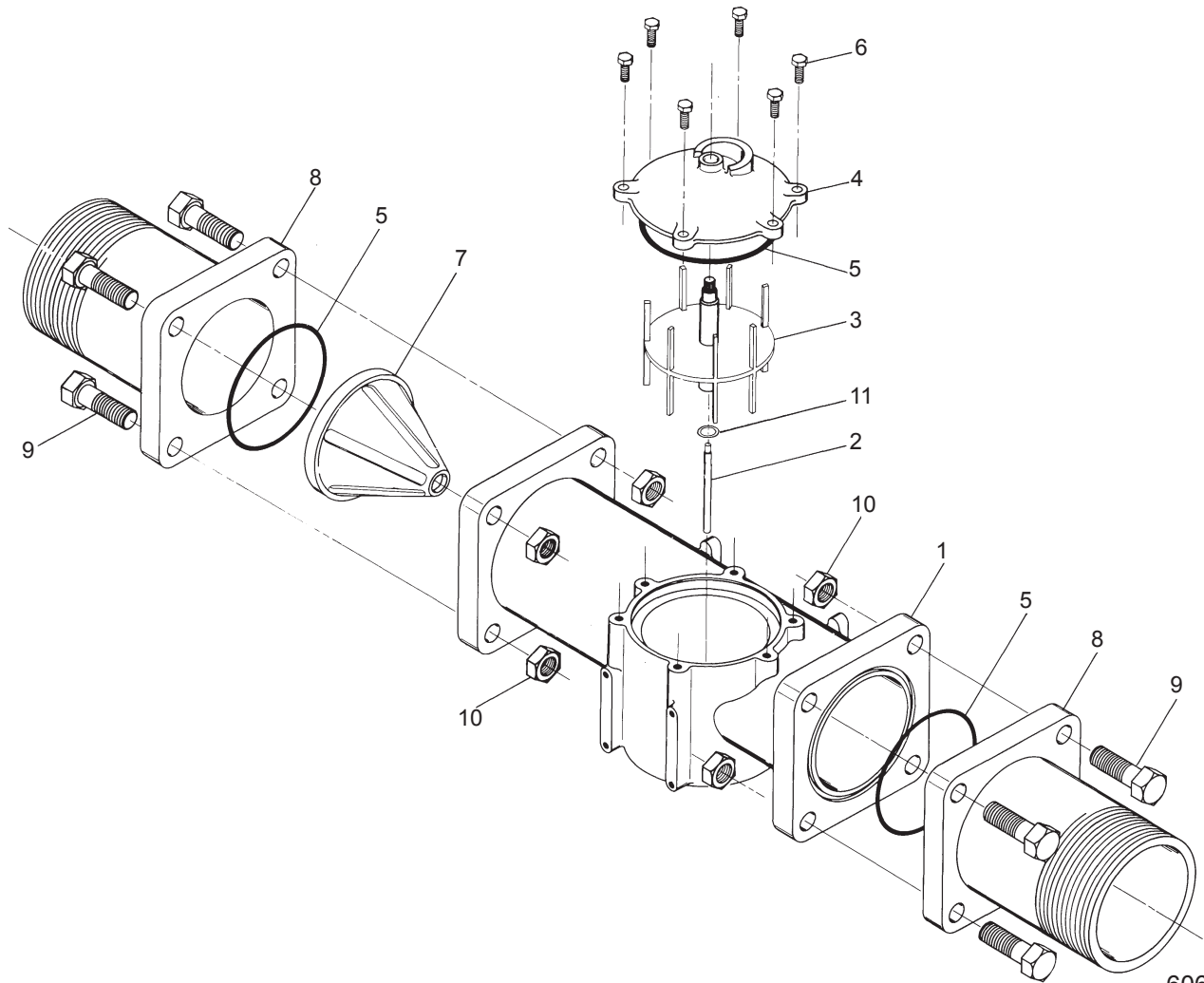

60608

Item No.	Quantity	Part No.	Description
1	1	16254	Meter Body
2	1	16279	Impeller Shaft
3	1	16575	Impeller Assembly
4	1	16400	Meter Cover Assembly - Standard
	1	16401	Meter Cover Assembly - Extension Range
5	3	15707	O-Ring - 236
6	6	12112	Screw - Hex Head
	6	15886	Screw - Hex Head (Metric)
7	1	16280	Flow Straightener
8	2	16328	Connecting Flange
9	8	40118	Screw - Hex Head
	8	17122	Screw - Hex Head (Metric)
10	8	16386	Nut - 1/2-13
11	1	16574	Stainless Steel Washer

2350 Safety Brine Valve Assembly

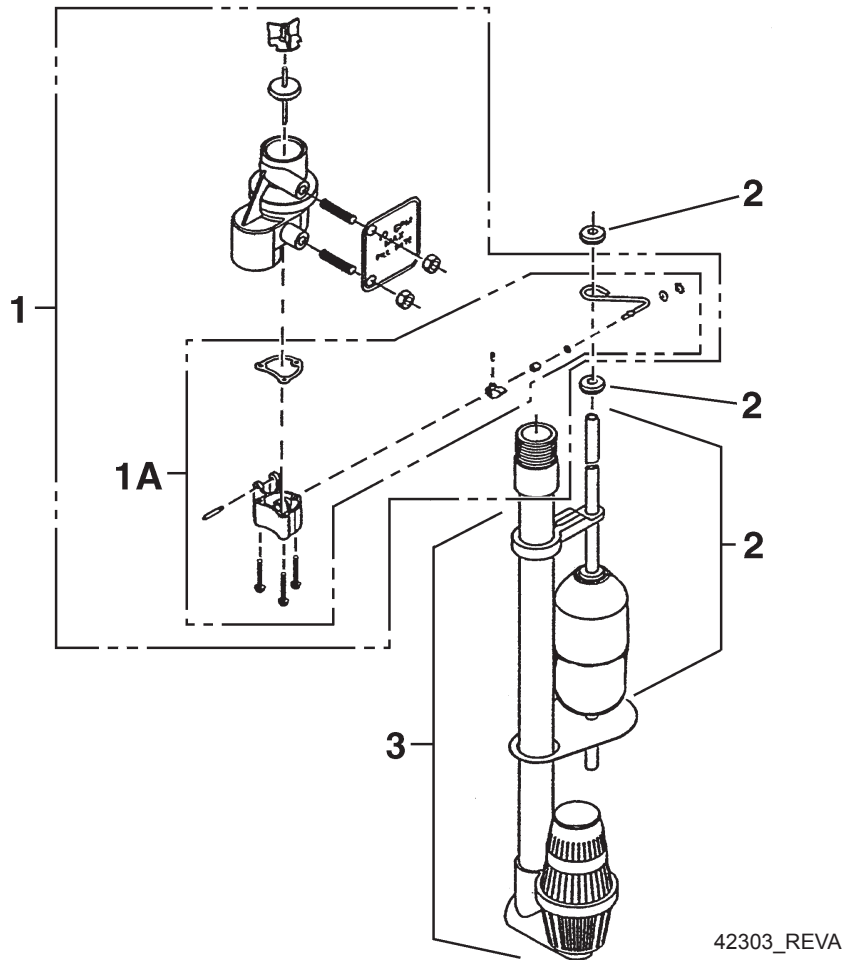

Item No.	Quantity	Part No.	Description
1.....	1	60038	Safety Brine Valve, 2350
1A	1	61024	Actuator Assembly, 2350 Brine
2.....	1	60028-30.....	Float Assembly, 2350, 30" Wht
3.....	1	60009-00.....	Air Check, #900, Commercial Less Fittings

Not Shown:

.....	1	18603	Fitting Assembly, 900 Air Check 2350
.....	1	18602	Fitting Assembly, 900 Air Check

For Service Assembly Numbers, See the Back of this Manual

Troubleshooting

Problem	Cause	Correction
1. Water conditioner fails to regenerate.	A. Electrical service to unit has been interrupted	A. Assure permanent electrical service (check fuse, plug, pull chain, or switch)
	B. Timer is defective.	B. Replace timer.
	C. Power failure.	C. Reset time of day.
2. Hard water.	A. Bypass valve is open.	A. Close by-pass valve.
	B. No salt is in brine tank.	B. Add salt to brine tank and maintain salt level above water level.
	C. Injector screen plugged.	C. Clean injector screen.
	D. Insufficient water flowing into brine tank.	D. Check brine tank fill time and clean brine line flow control if plugged.
	E. Hot water tank hardness.	E. Repeated flushings of the hot water tank is required.
	F. Leak at distributor tube.	F. Make sure distributor tube is not cracked. Check O-ring and tube pilot.
	G. Internal valve leak.	G. Replace seals and spacers and/or piston.
3. Unit used too much salt.	A. Improper salt setting.	A. Check salt usage and salt setting.
	B. Excessive water in brine tank.	B. See problem 7.
4. Loss of water pressure.	A. Iron buildup in line to water conditioner.	A. Clean line to water conditioner.
	B. Iron buildup in water conditioner.	B. Clean control and add mineral cleaner to mineral bed. Increase frequency of regeneration.
	C. Inlet of control plugged due to foreign material broken loose from pipes by recent work done on plumbing system.	C. Remove piston and clean control.
5. Loss of mineral through drain line.	A. Air in water system.	A. Assure that well system has proper air eliminator control. Check for dry well condition.
	B. Improperly sized drain line flow control.	B. Check for proper drain rate.
6. Iron in conditioned water.	A. Fouled mineral bed.	A. Check backwash, brine draw, and brine tank fill. Increase frequency of regeneration. Increase backwash time.
7. Excessive water in brine tank.	A. Plugged drain line flow control.	A. Clean flow control.
	B. Plugged injector system.	B. Clean injector and screen.
	C. Timer not cycling.	C. Replace timer.
	D. Foreign material in brine valve.	D. Replace brine valve seat and clean valve.
	E. Foreign material in brine line flow control.	E. Clean brine line flow control.

Troubleshooting

Problem	Cause	Correction
8. Softener fails to draw brine.	A. Drain line flow control is plugged.	A. Clean drain line flow control.
	B. Injector is plugged.	B. Clean injector
	C. Injector screen plugged.	C. Clean screen.
	D. Line pressure is too low.	D. Increase line pressure to 20 psi.
	E. Internal control leak	E. Change seals, spacers, and piston assembly.
	F. Service adapter did not cycle.	F. Check drive motor and switches.
9. Control cycles continuously.	A. Misadjusted, broken, or shorted switch.	A. Determine if switch or timer is faulty and replace it, or replace complete power head.
10. Drain flows continuously.	A. Valve is not programming correctly.	A. Check timer program and positioning of control. Replace power head assembly if not positioning properly.
	B. Foreign material in control.	B. Remove power head assembly and inspect bore. Remove foreign material and check control in various regeneration positions.
	C. Internal control leak.	C. Replace seals and piston assembly.

General Service Hints For Meter Control

Problem: Softener delivers hard water

Reason: Reserve capacity has been exceeded.

Correction: Check salt dosage requirements and reset program wheel to provide additional reserve.

Reason: Program wheel is not rotating with meter output.

Correction: Pull cable out of meter cover and rotate manually. Program wheel must move without binding and clutch must give positive clicks when program wheel strikes regeneration stop. If it does not, replace timer.

Reason: Meter is not measuring flow.

Correction: Check meter with meter checker.

Water Conditioner Flow Diagrams

1 SERVICE POSITION

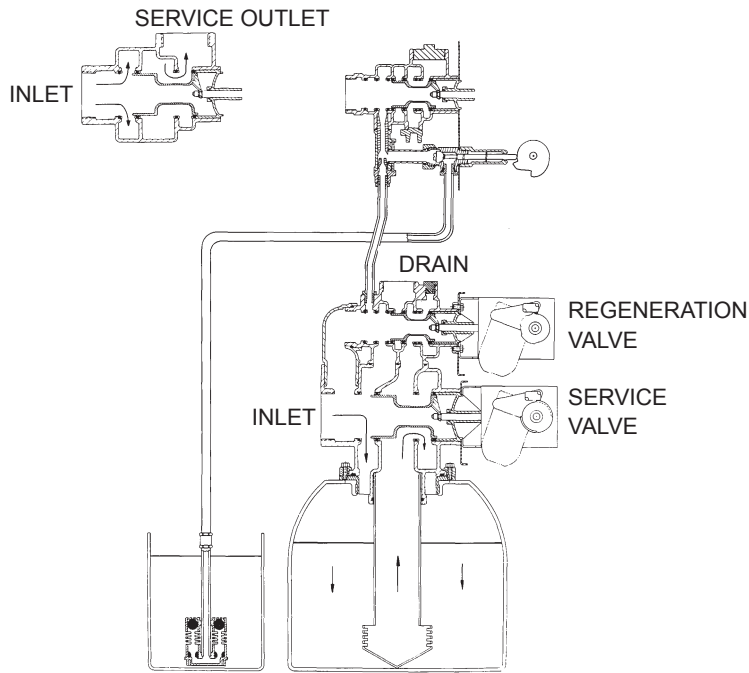

Hard water enters at valve inlet and flows down thru mineral to the bottom distributor. Conditioned water flows up thru the distributor tube, around the piston and out the outlet.

2 BACKWASH POSITION

NO HARD WATER BY-PASS

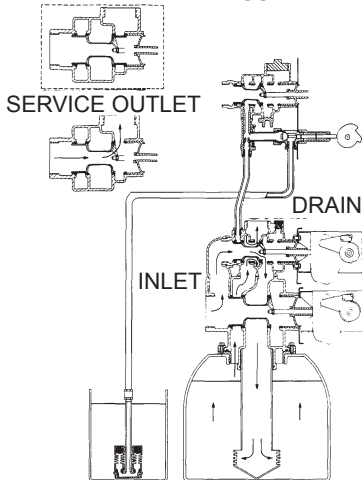

Hard water enters at valve inlet – flows thru service adapter piston for by-pass, and up thru coupling to regeneration valve inlet. Flow continues thru the regeneration valve piston – down the distributor tube – thru the bottom distributor and up thru the mineral – around the piston and out the drain. If optional no hard water by-pass piston is used, water flow to service outlet is prevented by an extension on the service outlet until the end of the rapid rinse cycle or brine tank refill cycle, depending on options chosen.

3 BRINE POSITION

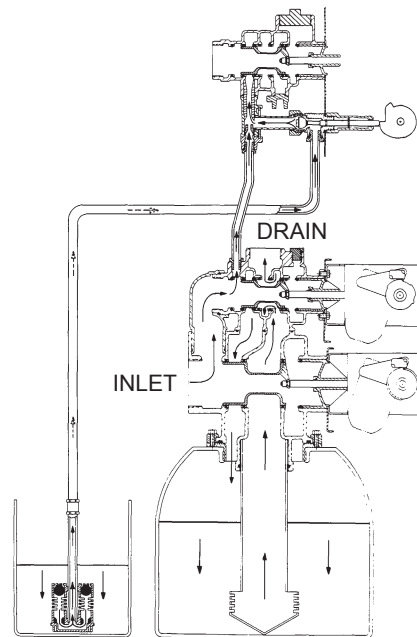

Hard water enters at valve inlet – flows thru injector nozzle and throat to draw brine from the brine tank. Brine flows down thru the mineral – into the bottom distributor – up the distributor tube – around the piston and out the drain.

Water Conditioner Flow Diagrams

4 SLOW RINSE POSITION

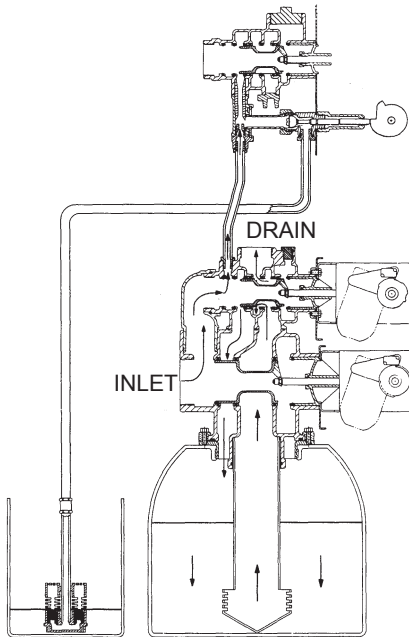

Hard water enters at valve inlet – flows thru injector nozzle and throat – down thru the mineral – into the bottom distributor – up the distributor tube – around the piston and out the drain.

5 RAPID RINSE POSITION

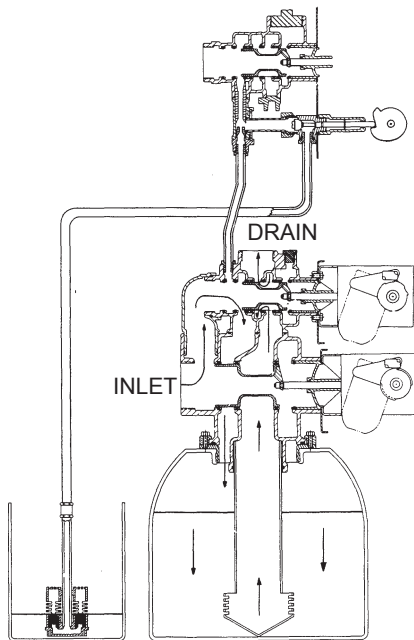

Hard water enters at valve inlet – flows thru the regeneration valve directly down thru the mineral – into the bottom distributor – up the distributor tube – around the piston and out the drain.

6 BRINE TANK REFILL POSITION

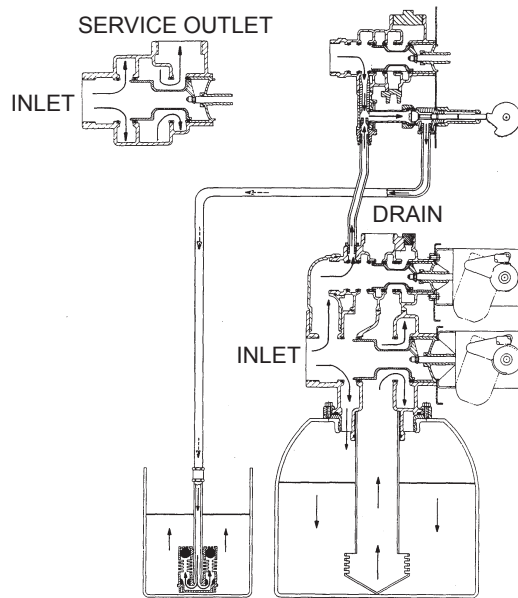

Hard water enters at valve inlet – flows thru nozzle and thru throat to brine valve to refill the brine tank. Inlet flow also continues down thru mineral to the bottom distributor. Conditioned water flows up thru the distributor tube, around the piston and out the outlet. Note: An option is available to keep service valve in by-pass position until the end of brine tank refill cycle.

Flow Data & Injector Draw Rates

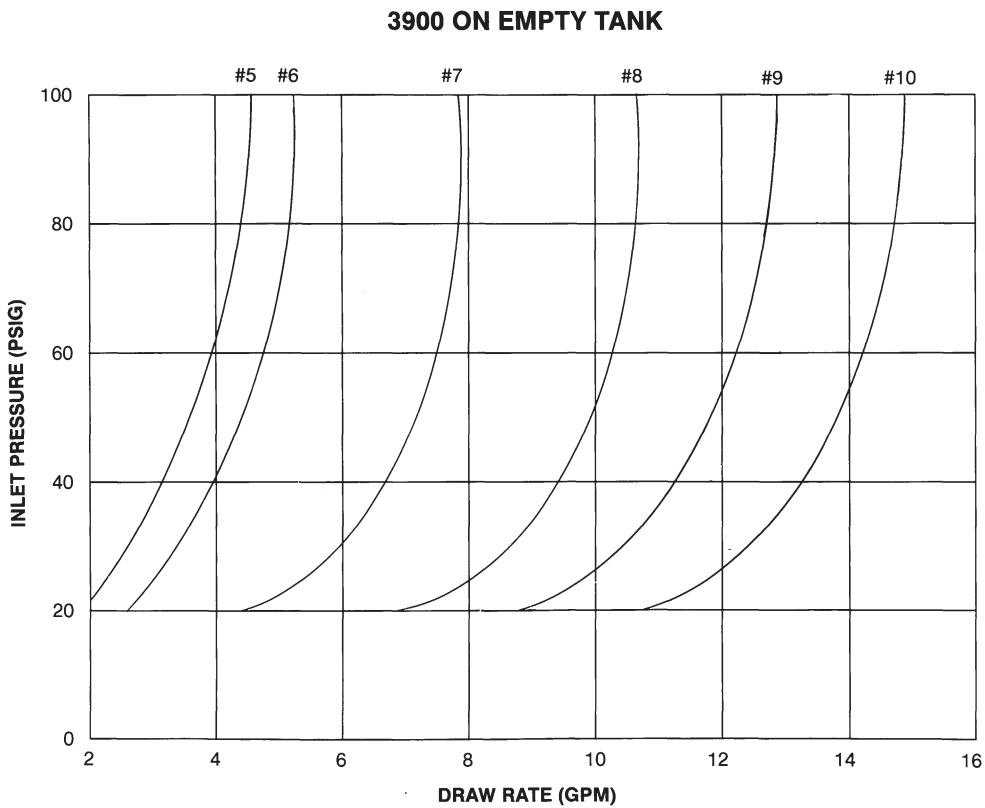
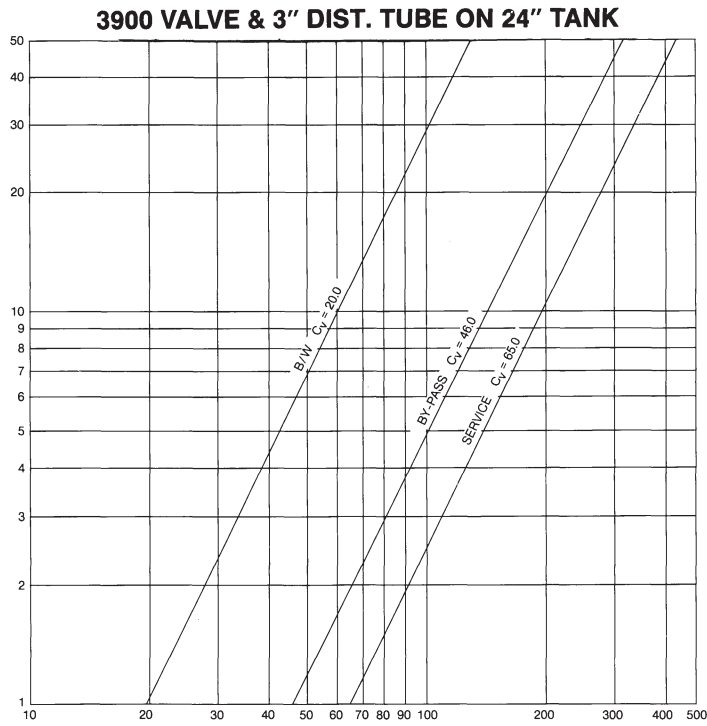

Dimensional Drawing 3900 Top Mount

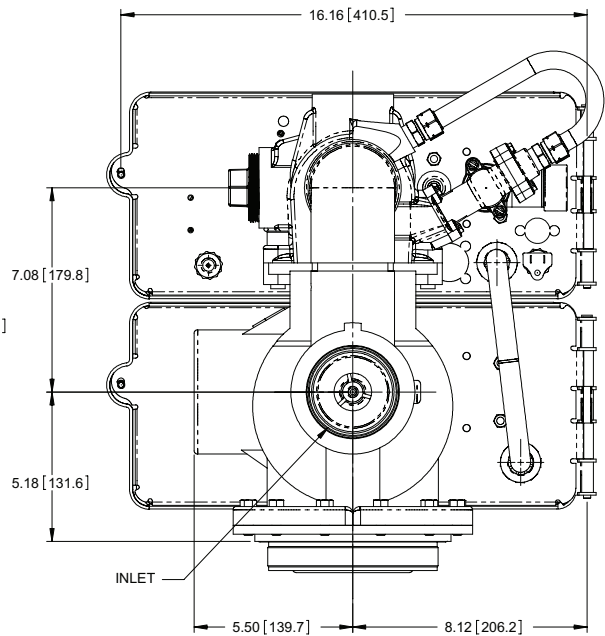
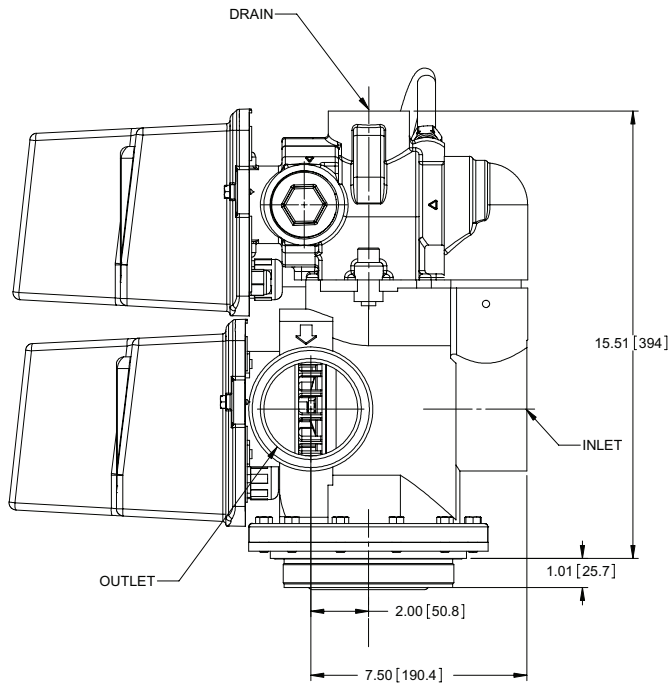
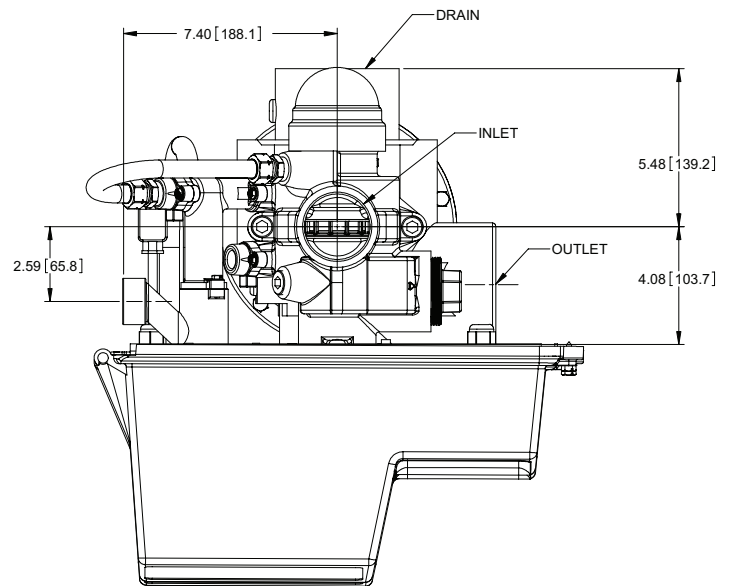
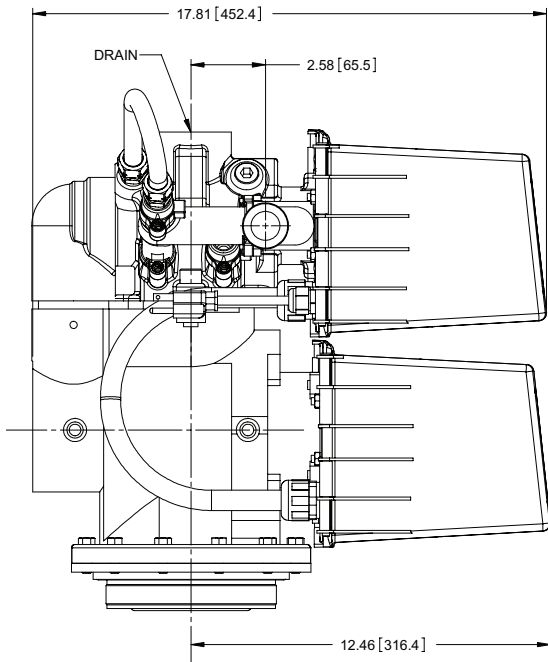

Dimensional Drawing 3900 Side Mount

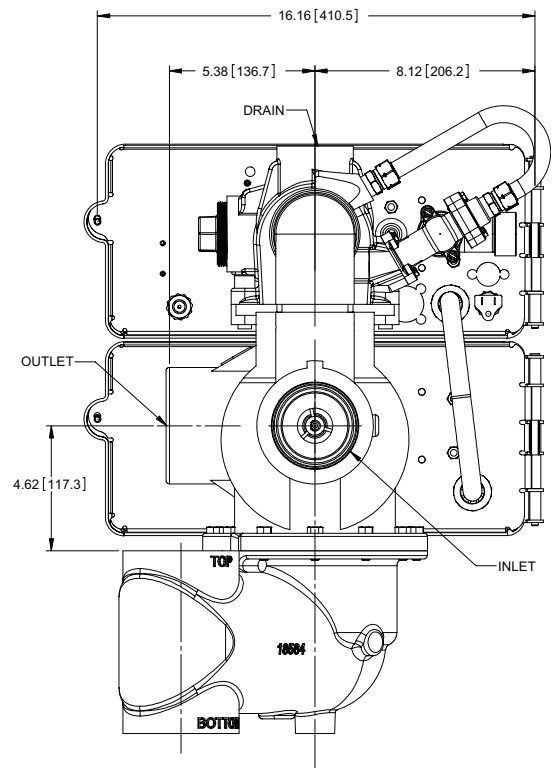
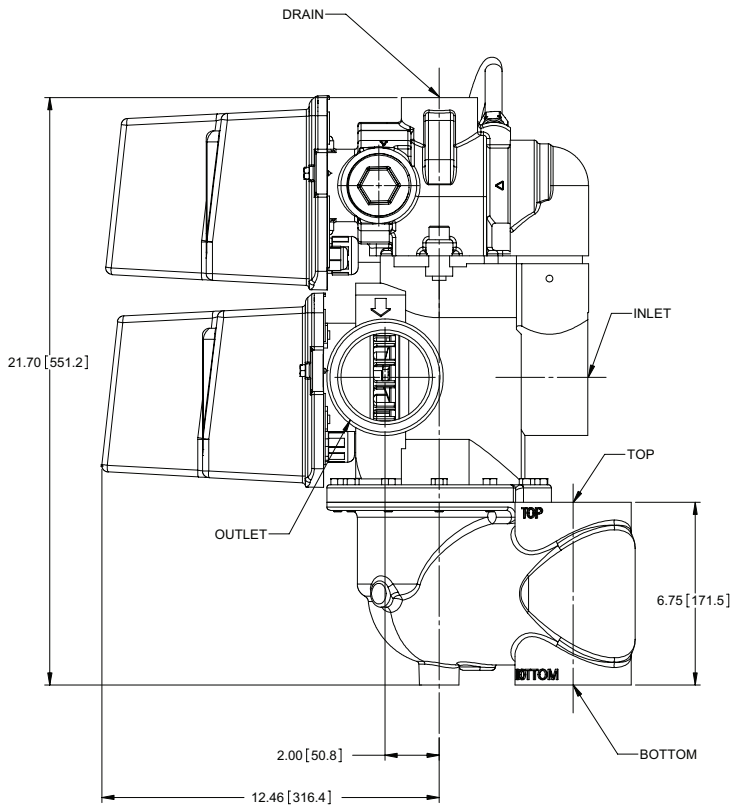
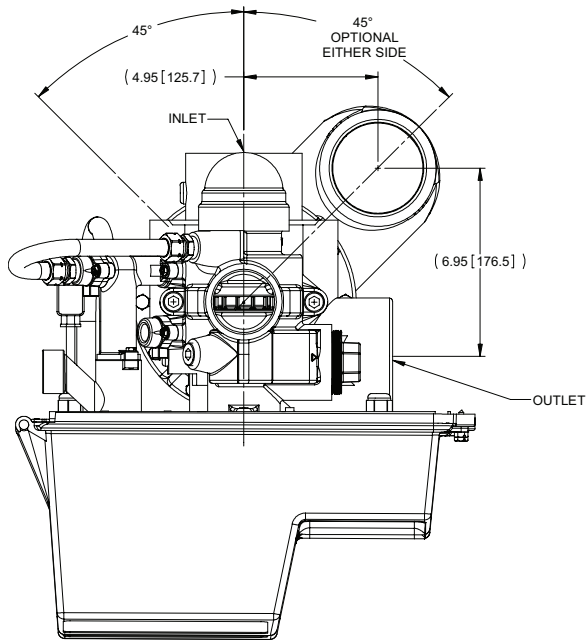

System #4 - Typical Single Tank Installation with Optional Meter

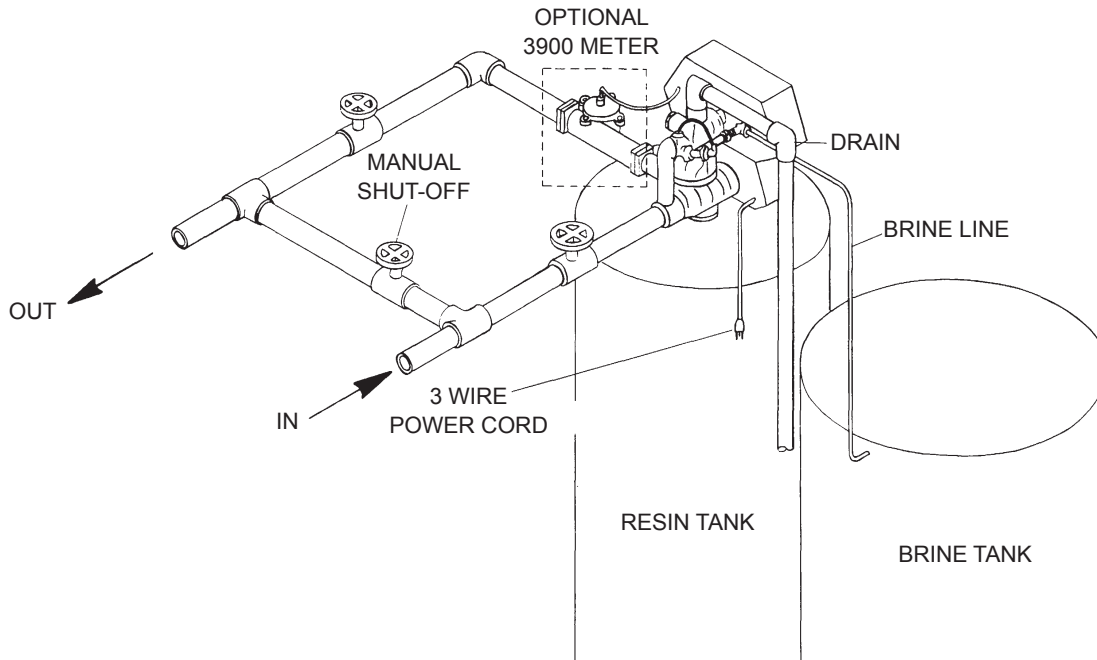

System #5 Interlock - Typical Twin Tank Installation with Optional Meter Interlock and No Hard Water Bypass

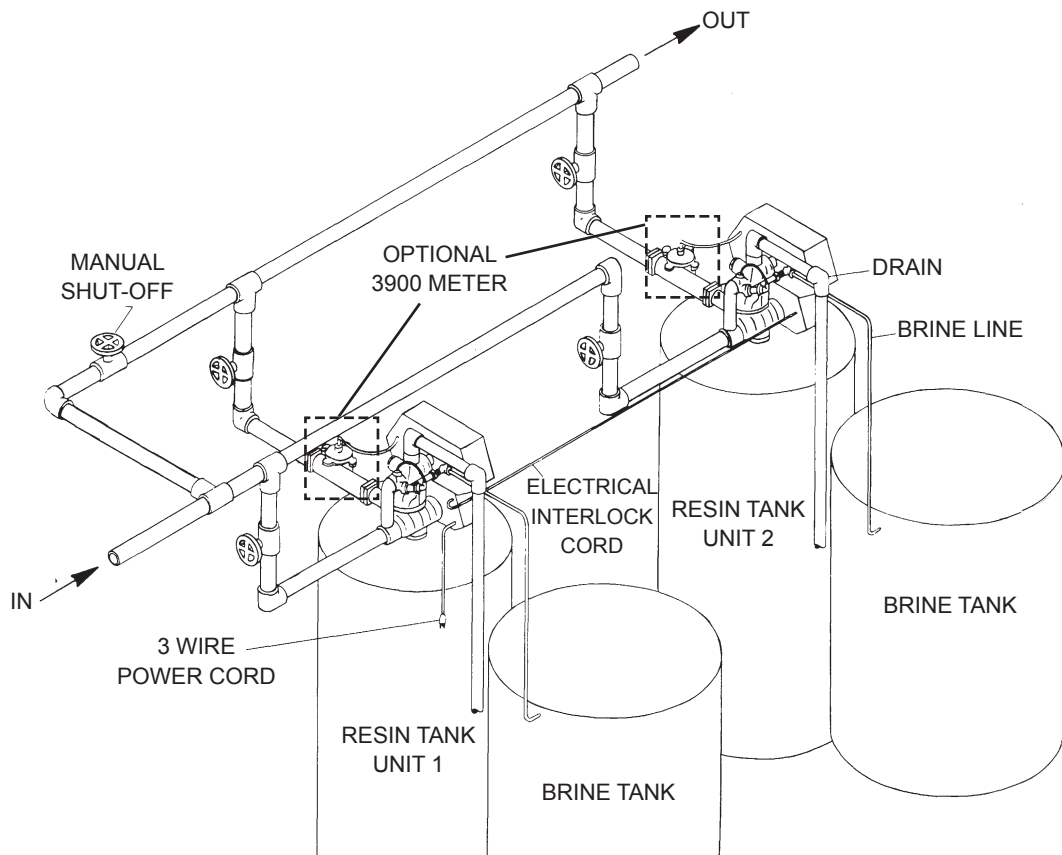

Typical Installations

System #6 Interlock - Typical Twin Tank Installation with Optional Meter Interlock and No Hard Water Bypass

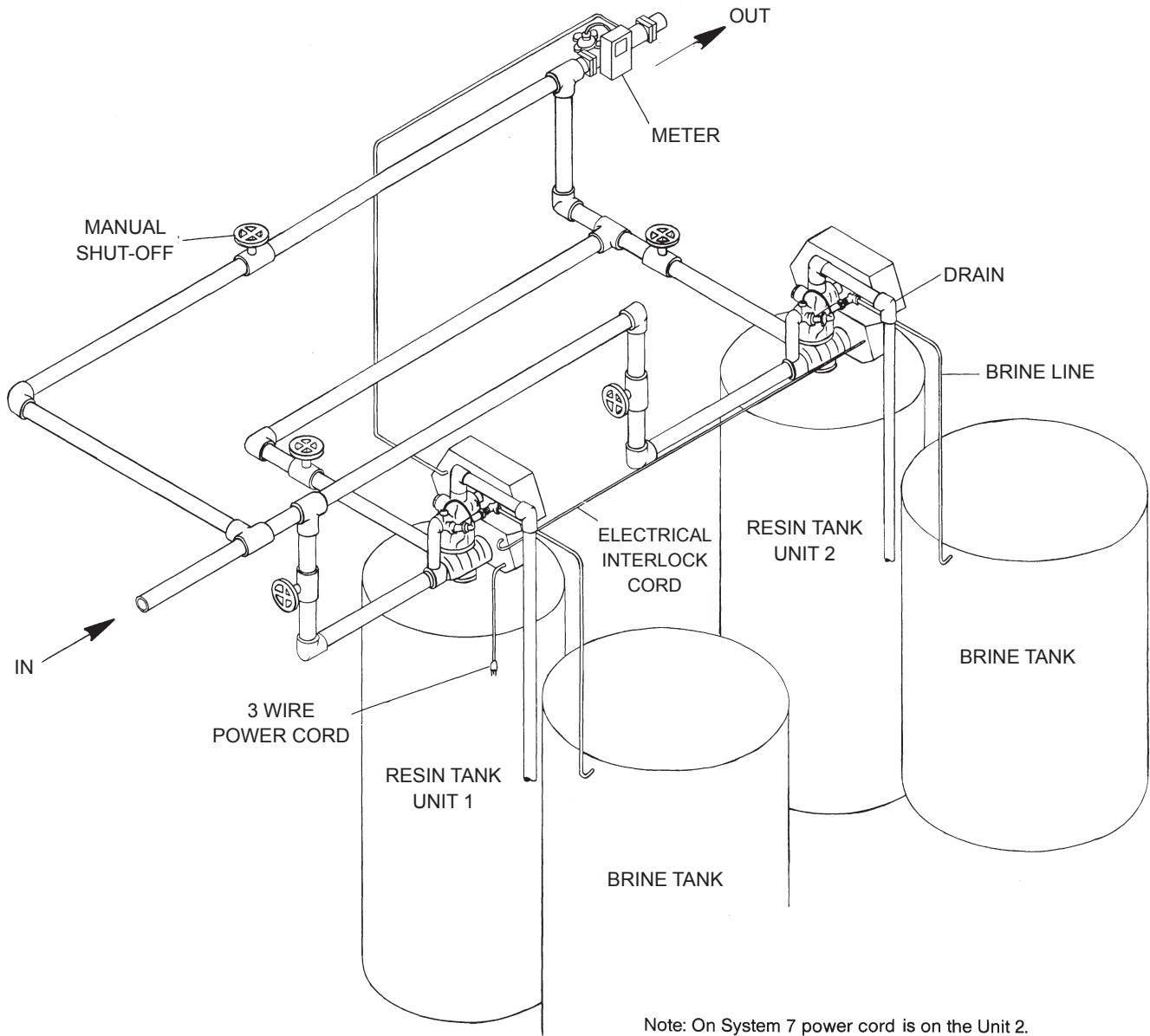

System #4 – Valve Wiring

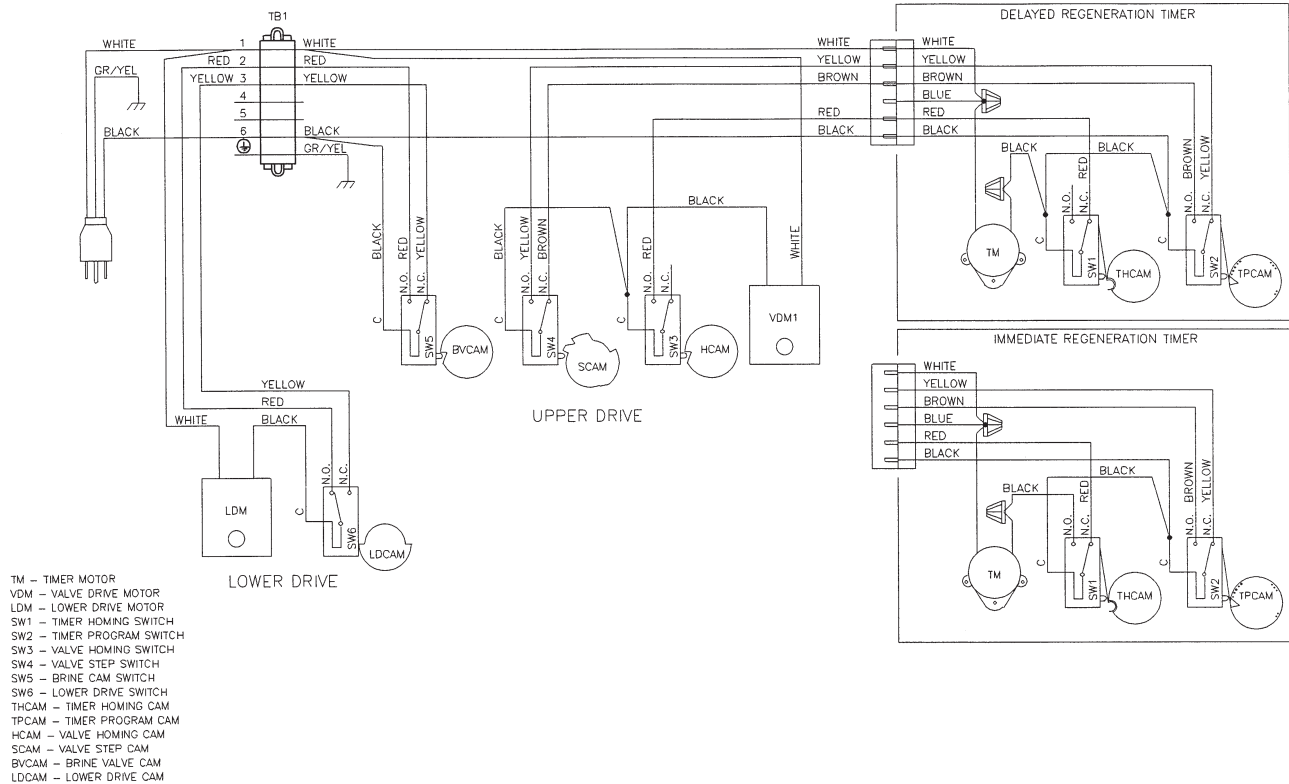

NOTE:
SINGLE TANK TIMECLOCK, METER DELAYED, OR METER IMMEDIATE REGENERATION

System #4 With Remote Meter – Valve Wiring

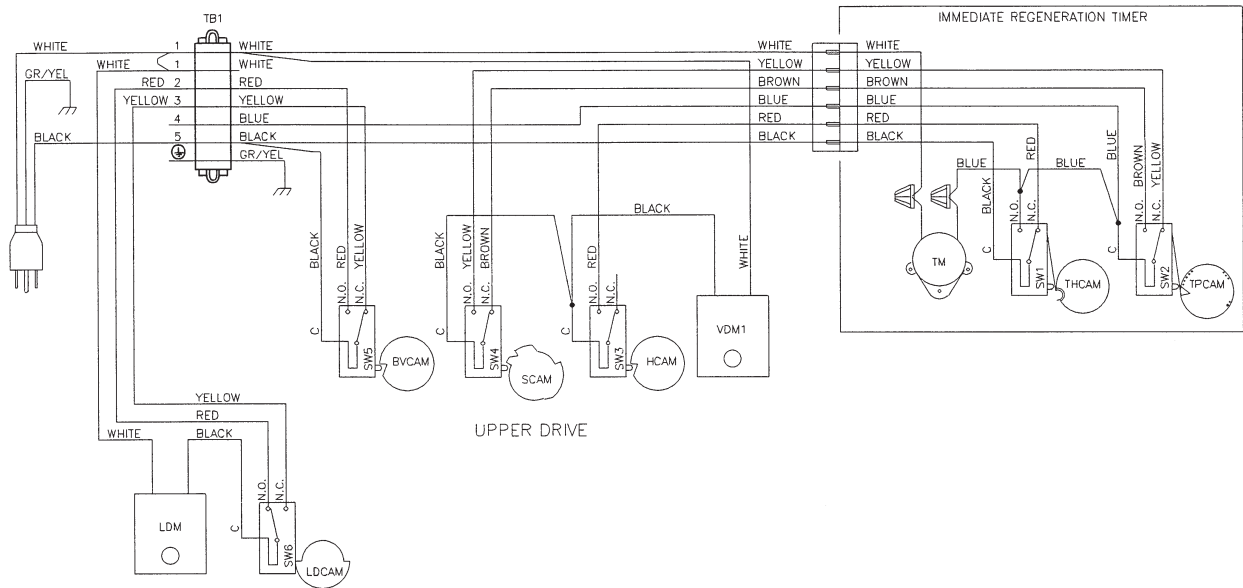

- TM – TIMER MOTOR
- VDM – VALVE DRIVE MOTOR
- LDM – LOWER DRIVE MOTOR
- SW1 – TIMER HOMING SWITCH
- SW2 – TIMER PROGRAM SWITCH
- SW3 – VALVE HOMING SWITCH
- SW4 – VALVE STEP SWITCH
- SW5 – BRINE CAM SWITCH
- SW6 – LOWER DRIVE SWITCH
- THCAM – TIMER HOMING CAM
- TPCAM – TIMER PROGRAM CAM
- HCAM – VALVE HOMING CAM
- SCAM – VALVE STEP CAM
- BVCAM – BRINE VALVE CAM
- LDCAM – LOWER DRIVE CAM

NOTE:
SINGLE TANK REMOTE METER DELAYED, OR IMMEDIATE REGENERATION

REMOTE METER WIRING

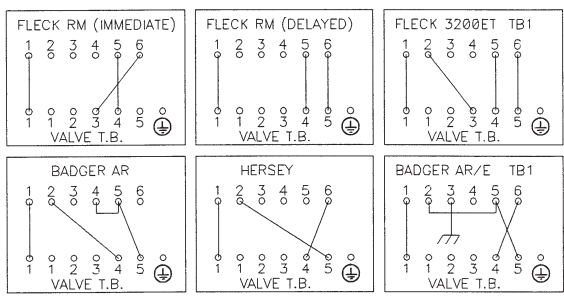

System #5 – Valve Wiring

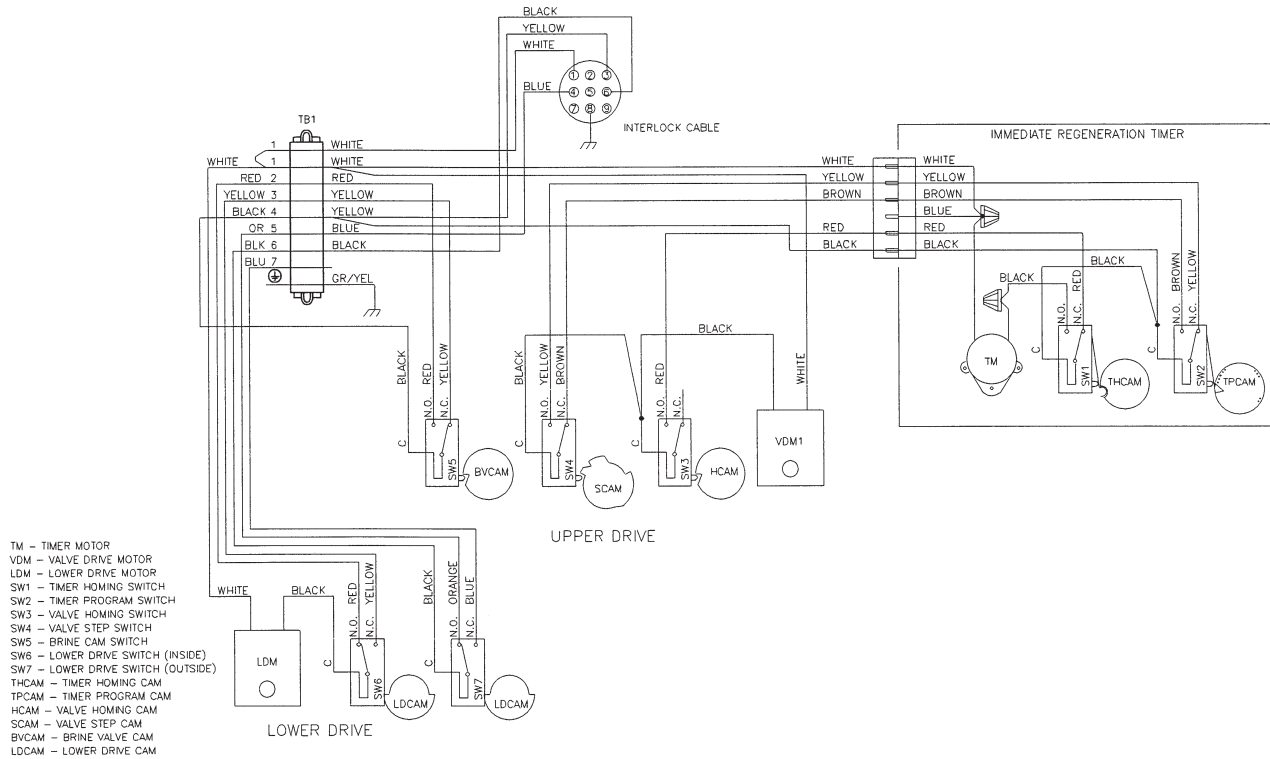
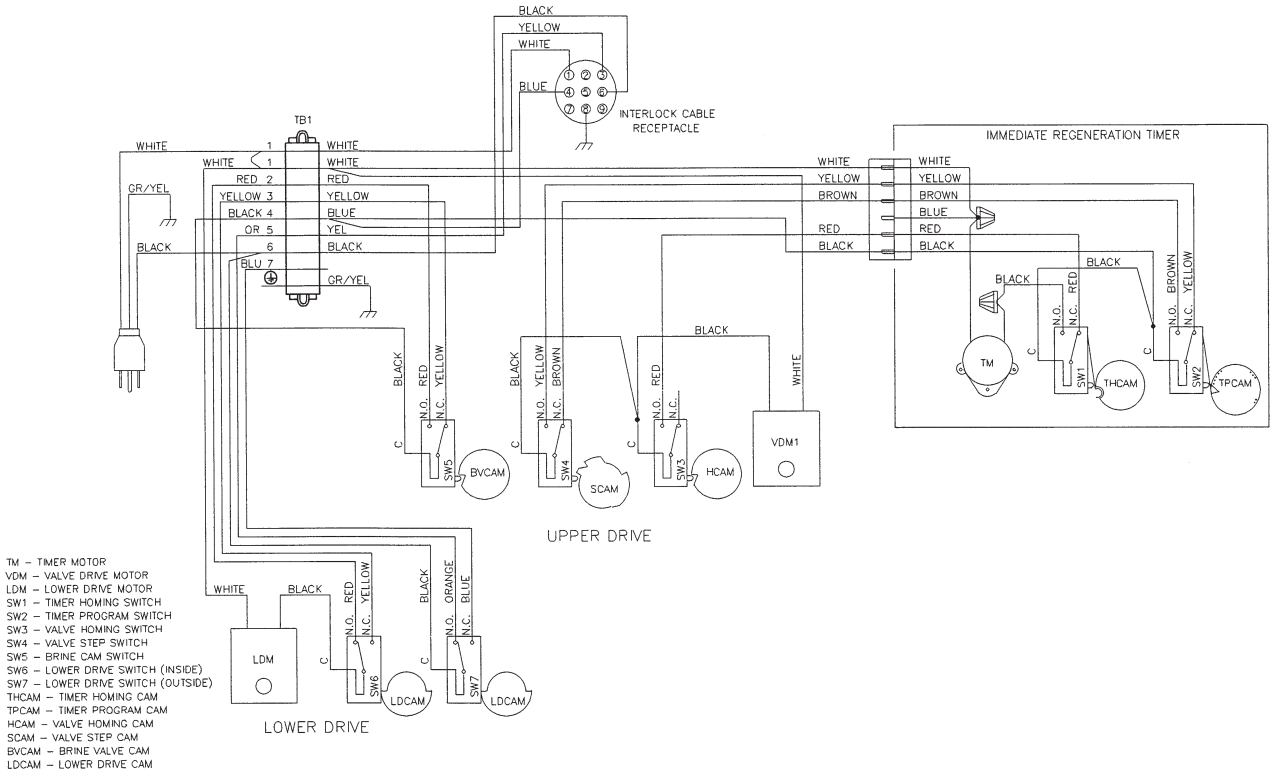

System #6 – Valve Wiring

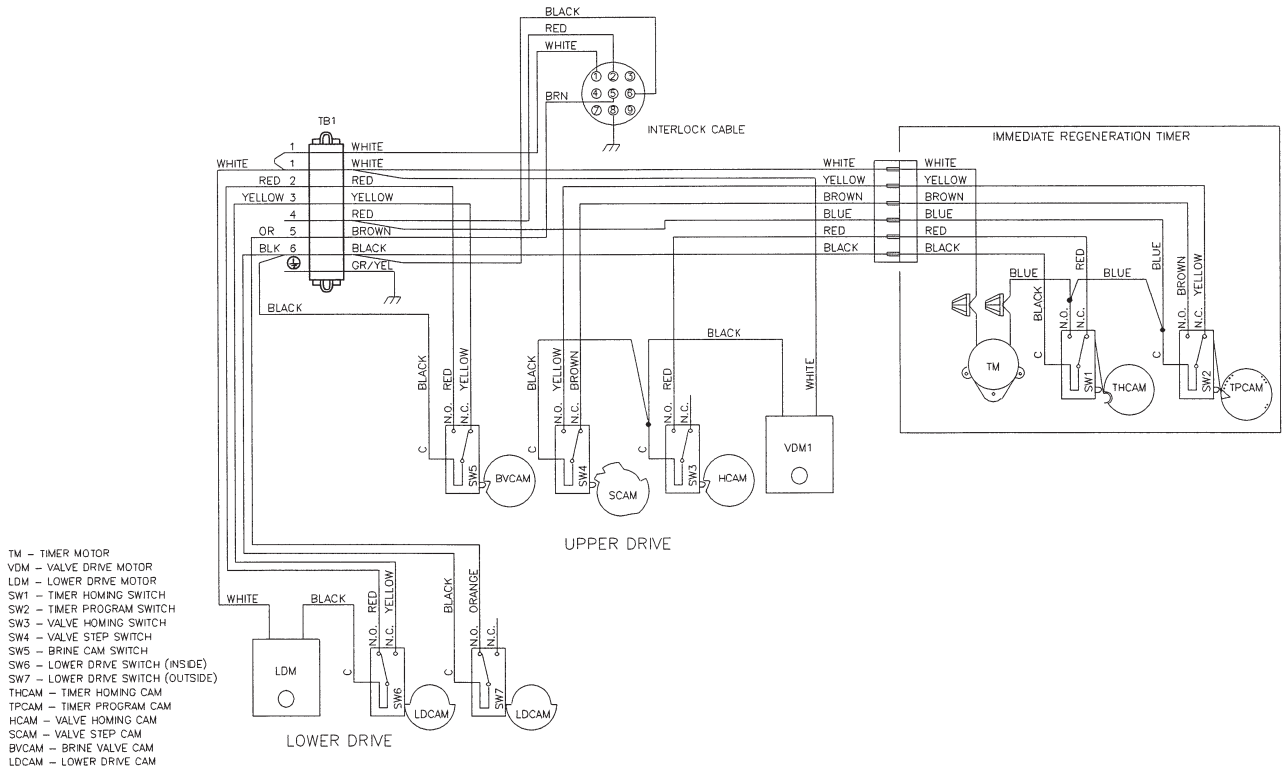
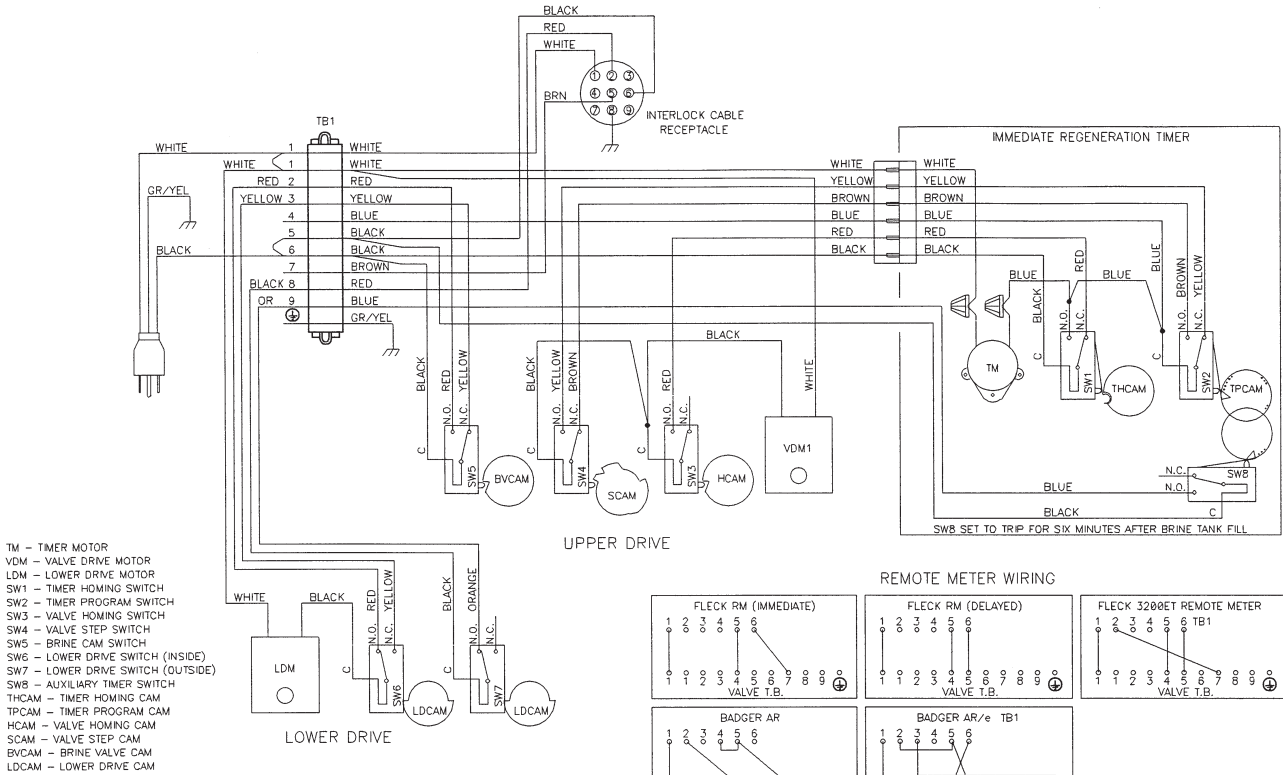

System #7 – Valve Wiring

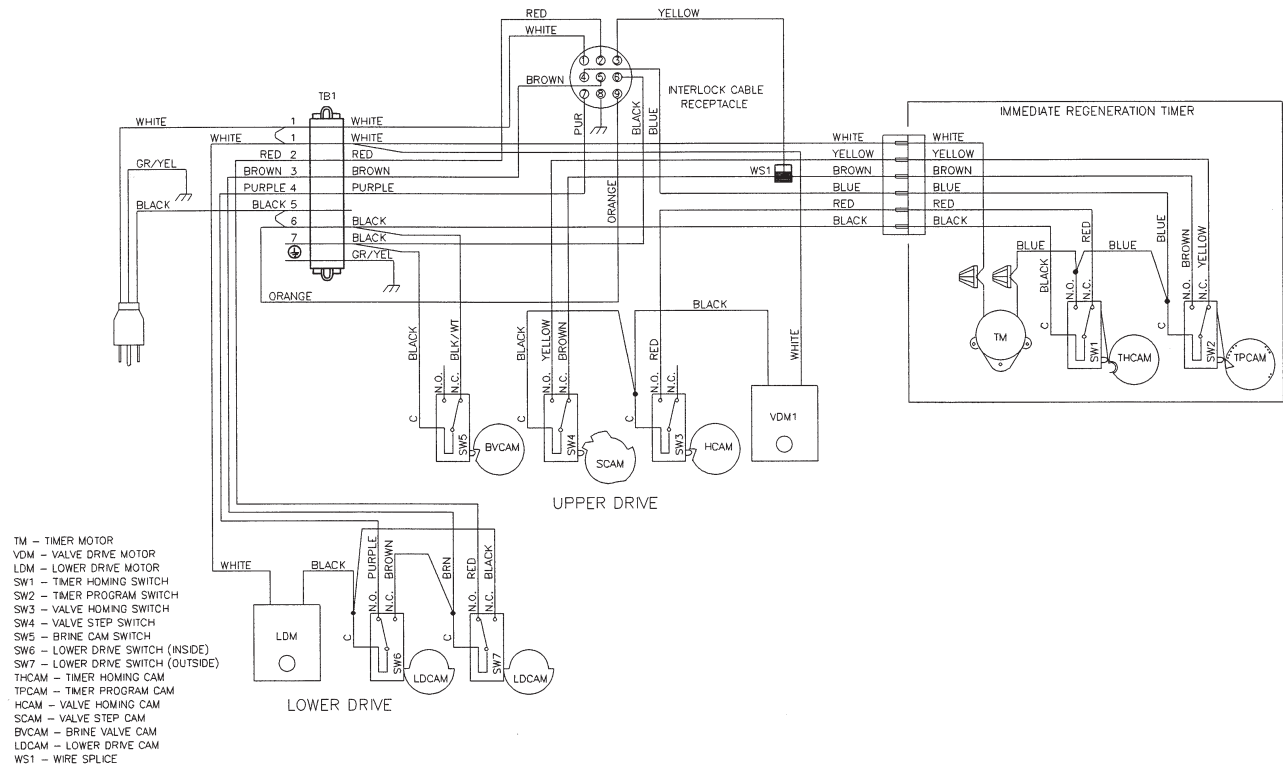
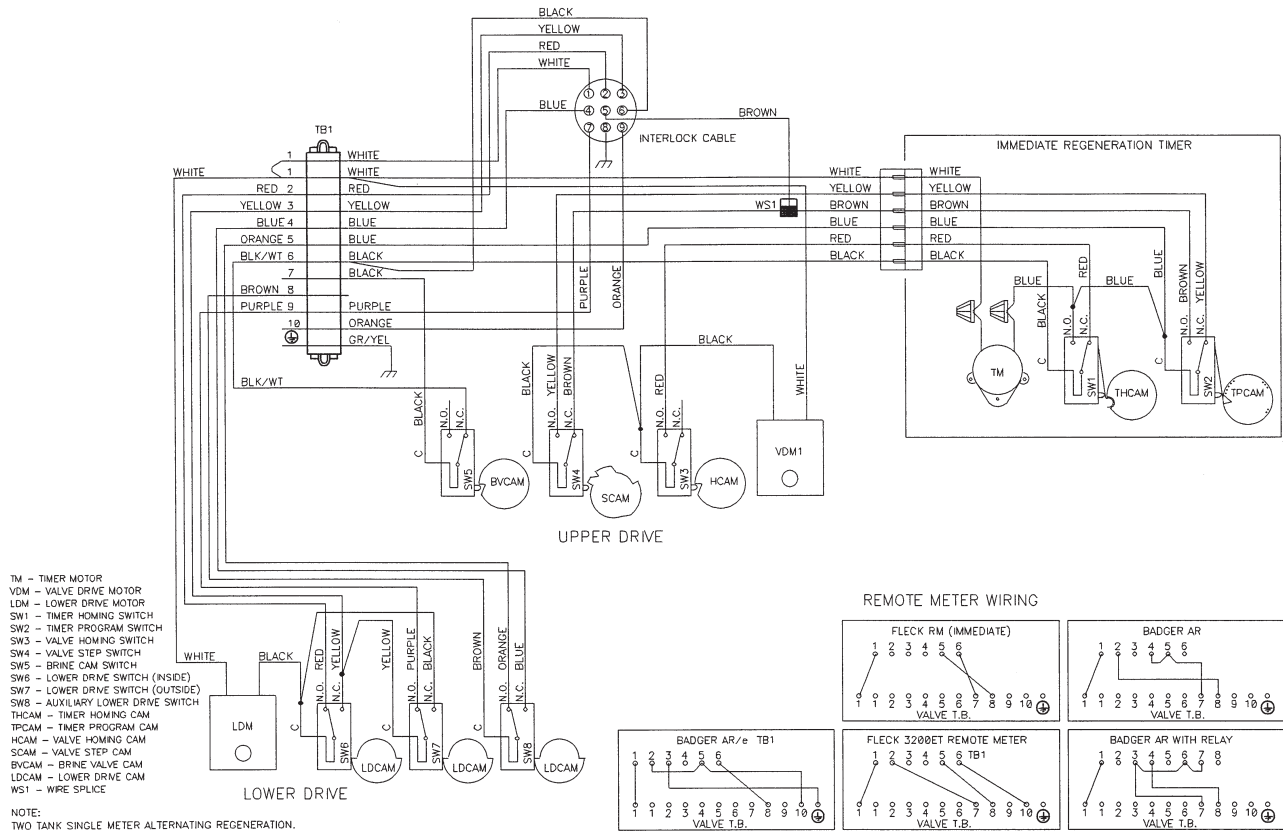

System #7 – Multivalve Valve Wiring

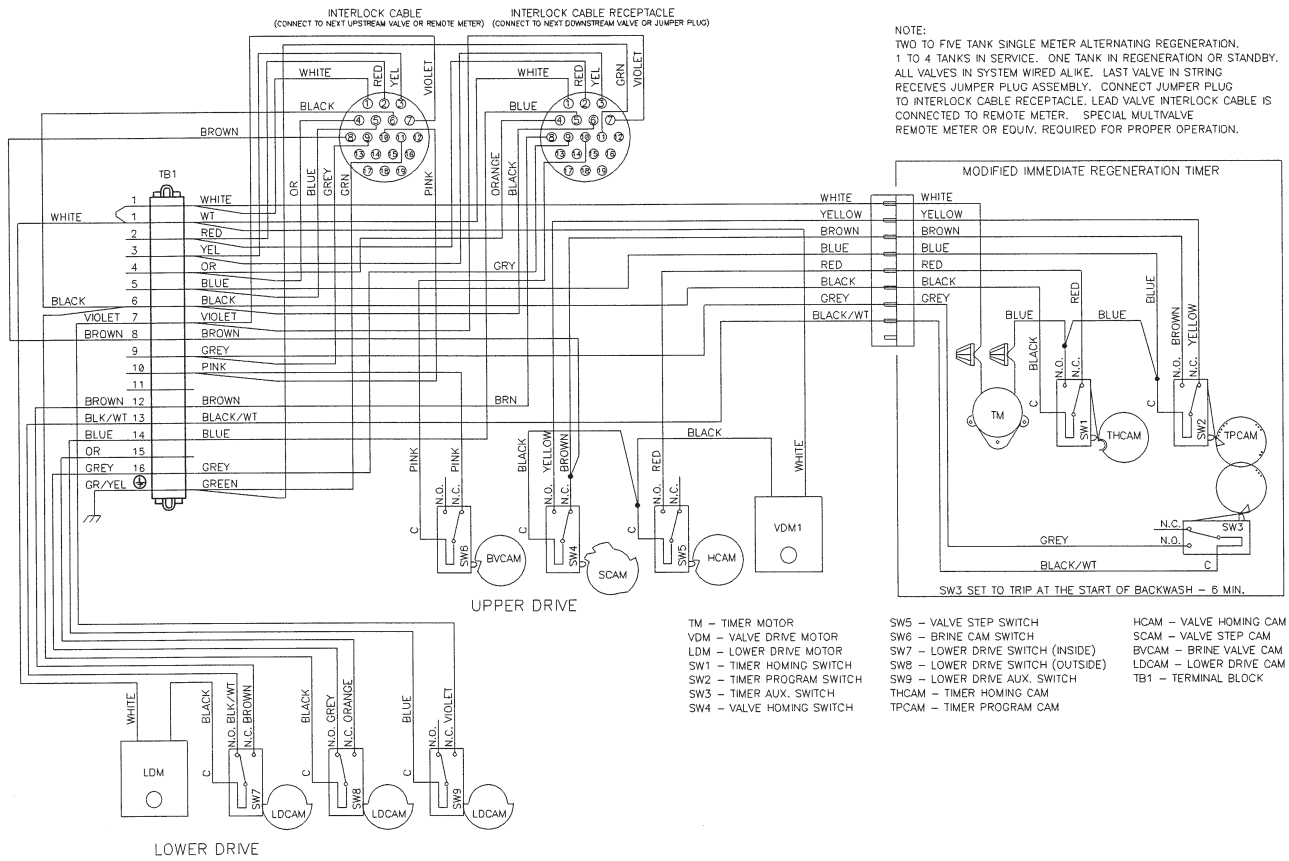

Service Assemblies

60036-02 1800 Brine Valve:

11772..... Spring
11774..... Retaining Ring
18713..... Brine Valve Body
16497-01 Brine Stem Assembly
16498-01 Stem Guide Assembly

60277-xx 1800 Injector Assembly:

12473..... Screw - Hex Head
15127-xx..... Injector Throat
15128-xx..... Injector Nozzle
15246..... O-ring -116
16340..... Injector Body
16341-01 Injector Cover
-xx Specify Size

60160-00 3900 Upper Piston Assembly:

14818..... Clip Piston Rod
14922..... O-ring -035
15125..... Piston Rod
16130..... Piston
16389-0 End Plug Assembly

60107-00 3900 Lower Piston - Hard Water Bypass:

14818..... Clip Piston Rod
16071..... Piston
16072..... Piston Rod
16076..... O-ring -042
16399-01 End Plug Assembly - White

60107-10 3900 Lower Piston - No Hard Water Bypass:

14818..... Clip Piston Rod
16082..... Piston - No Hard Water Bypass
16072..... Piston Rod
16076..... O-ring -042
16399-11 End Plug Assembly - Black

60131..... 3900 Upper Seal Kit:

10368..... Spacer
10369..... Spacer - Port
11720..... Seal

60132..... 3900 Lower Seal Kit:

16068..... Seal
16069..... Spacer - Narrow
16070..... Spacer - Wide

60057-01 3900 Upper Drive Motor Assembly - 115 V.:

10302..... Insulator - Switch
10872..... Screw - Hex Head
11080..... Screw - Flat Head
10218..... Switch
10300..... Screw - Hex Head
15120..... Bracket - Motor Mounting
40392..... Drive Motor - 115 V. 50/60 Hz
16052..... Blushing
17797..... Bracket - Switch Mounting
12624..... Screw - Pan Head

60058-01 3900 Lower Drive Motor Assembly - 115 V. System #4:

10302..... Insulator - Switch
10872..... Screw - Hex Head
11080..... Screw - Flat Head
10218..... Switch
10300..... Screw - Hex Head
11805..... Screw - Pan Head
40392..... Drive Motor - 115V. 50/60 Hz
17797..... Bracket - Switch Mounting
16086..... Bracket - Motor Mounting

60131-10 3900 Upper Seal Kit:

10368..... Spacer
10369..... Spacer
11720-02..... Seal, 1-1/2", Silicone

60132-10 3900 Lower Seal Kit:

41534..... Seal, 3900, 558 Bypass
16069..... Spacer, 3900
16070..... Spacer, 3900

60038..... Safety Brine Valve, 2350:

60028-30 Float Assembly, White
60009-00 #900 Air Check, Less Fittings
18602..... Kit, Fitting, 1700 Brine, 900 Air Check
18603..... Kit, Fitting, 1700 Brine, 2350 Safety

61417..... Adapter Assy, Side Mount, 3900:

18584-02 Adapter, 3900 Side Mount
16257..... Segment, Flange
11238..... Screw, Hex, 5/16-18 x 1, 18-8 Stainless Steel
16345..... O-ring, 362
16800..... O-ring, 238
11533..... Plug, Pipe 1/4"

60150-3150 SVO, Assembly, 3150/3900**Drain Line Flow Controls (DLFC):**

60711-00..... 2" NPT, Less BTTNS, w/2 Holes
60711-000..... 2" NPT, Less BTTNS, w/3 Holes
60711-01..... 2" NPT, Less BTTNS, w/1 Hole
60711-20..... 2" NPT, 20 gpm
60711-25..... 2" NPT, 25 gpm, Brass
60711-30..... 2" NPT, 30 gpm
60711-35..... 2" NPT, 35 gpm
60711-40..... 2" NPT, 40 gpm
60711-45..... 2" NPT, 45 gpm
60711-50..... 2" NPT, 50 gpm
60711-55..... 2" NPT, 55 gpm
60711-60..... 2" NPT, 60 gpm
60711-65..... 2" NPT, 65 gpm
60711-70..... 2" NPT, 70 gpm
60711-75..... 2" NPT, 75 gpm
60711-80..... 2" NPT, 80 gpm
60711-85..... 2" NPT, 85 gpm
60711-90..... 2" NPT, 90 gpm
60711-95..... 2" NPT, 95 gpm
60711-100..... 2" NPT, 100 gpm

60812-30 2" BSP/ Metric, 30 gpm
60812-35 2" BSP/ Metric, 35 gpm
60812-45 2" BSP/ Metric, 45 gpm
60812-50 2" BSP/ Metric, 50 gpm
60812-55 2" BSP/ Metric, 55 gpm
60812-70 2" BSP/ Metric, 70 gpm
60812-75 2" BSP/ Metric, 75 gpm
60812-80 2" BSP/ Metric, 80 gpm
60812-90 2" BSP/ Metric, 90 gpm
60812-95 2" BSP/ Metric, 95 gpm
60812-100 2" BSP/ Metric, 100 gpm

Notes

2009 Pentair Residential Filtration, LLC
P/N 16505 Rev. C MA09

Distributed By Applied Membranes, Inc.
<http://www.appliedmembranes.com>