

Model 9000/9100/9500

Service Manual

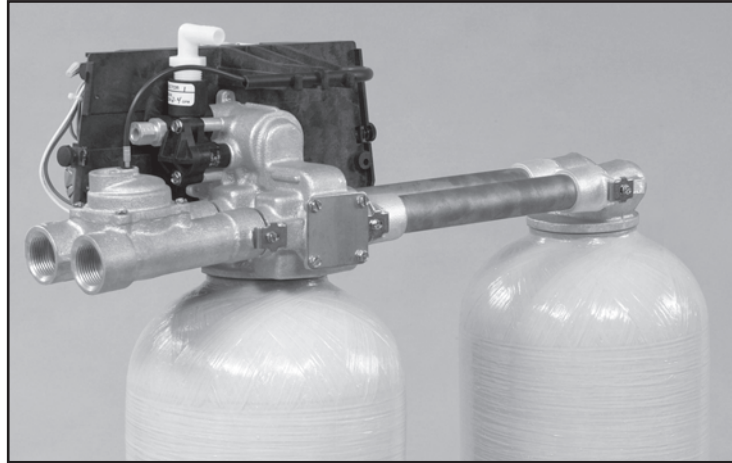

IMPORTANT: Fill in Pertinent Information on Page 3 for Future Reference

Table of Contents

Job Specification Sheet.....	3
Equipment Configuration.....	4
General and Commercial Installation Checklist.....	5
Valve to Tank Installation Instructions.....	7
Regeneration Cycle Program Setting Procedure.....	8
Time Brine Refill and Meter Setting Procedure.....	9
9000/9100/9500 Electro Mechanical Timer Assembly.....	12
Power Head Assembly.....	14
9000 Control Valve Assembly.....	16
9100 Control Valve Assembly.....	18
9500 Control Valve Assembly.....	20
1600 Brine Valve System (for 9500).....	22
1700 Brine Valve System (for 9500).....	23
9000 Second Tank Assembly.....	24
9100 Second Tank Assembly.....	25
9500 Second Tank Assembly.....	26
3/4" Meter Assembly.....	27
1" Meter Assembly.....	28
1 1/2" Meter Assembly.....	29
9000/9100 Bypass Valve Assembly.....	30
Bypass Valve Assembly.....	31
1710 Brine Valve System (for 9500).....	32
2300 Safety Brine Valve.....	33
2310 Safety Brine Valve.....	34
2350 Safety Brine Valve.....	35
Troubleshooting.....	36
General Hints for Meter Control.....	37
9000/9100/9500 Meter Flow Data.....	38
9000/9100 Injector Flow Data (1600 Series Injectors).....	39
9500 Injector Flow Data (1600 & 1700 Series Injectors).....	40
9000 Control Dimensions.....	41
9100 Control Dimensions.....	42
9500 Control Dimensions.....	43
Water Conditioner Flow Diagram.....	44
9000/9500 Wiring Diagram.....	46
Service Assemblies.....	47



IMPORTANT PLEASE READ:

- The information, specifications and illustrations in this manual are based on the latest information available at the time of printing. The manufacturer reserves the right to make changes at any time without notice.
- This manual is intended as a guide for service of the valve only. System installation requires information from a number of suppliers not known at the time of manufacture. This product should be installed by a plumbing professional.
- This unit is designed to be installed on potable water systems only.
- This product must be installed in compliance with all state and municipal plumbing and electrical codes. Permits may be required at the time of installation.
- If daytime operating pressure exceeds 80 psi, nighttime pressures may exceed pressure limits. A pressure reducing valve must be installed.
- Do not install the unit where temperatures may drop below 32°F (0°C) or above 125°F (52°C).
- Do not place the unit in direct sunlight. Black units will absorb radiant heat increasing internal temperatures.
- Do not strike the valve or any of the components.
- Warranty of this product extends to manufacturing defects. Misapplication of this product may result in failure to properly condition water, or damage to product.
- A prefilter should be used on installations in which free solids are present.
- In some applications local municipalities treat water with Chloramines. High Chloramine levels may damage valve components.
- Correct and constant voltage must be supplied to the control valve to maintain proper function.

Job Specification Sheet

Job Number: _____

Model Number: _____

Water Test: _____

Capacity Per Unit: _____

Mineral Tank Size: _____ Diameter: _____ Height: _____

Brine Tank Size & Salt Setting per Regeneration: _____

9000/9100/9500 Control Valve Specifications:

1. **Type of Timer:**

- A. 82 minute available regeneration time, 1/15 RPM
- B. 164 minute available regeneration time, 1/30 RPM

2. **Type of Meter:**

Mechanical Valves (Gallon Settings)

Meter	Standard Range	Extended Range
3/4"	125 - 2,125	625 - 10,625
1"	310 - 5,270	1,150 - 26,350
1-1/2"	625 - 10,625	3,125 - 53,125

3. Timer Gallon Setting: _____ Gallons

4. Regeneration Program Setting:

A. Backwash: _____ Minutes

B. Brine and Slow Rinse: _____ Minutes

C. Rapid Rinse: _____ Minutes

D. Brine Tank Refill: _____ Minutes

5. Drain Line Flow Control: _____ gpm

6. Brine Refill Rate: _____ gpm

7. Injector Size: _____

Equipment Configuration

9000/9100 Equipment Configuration

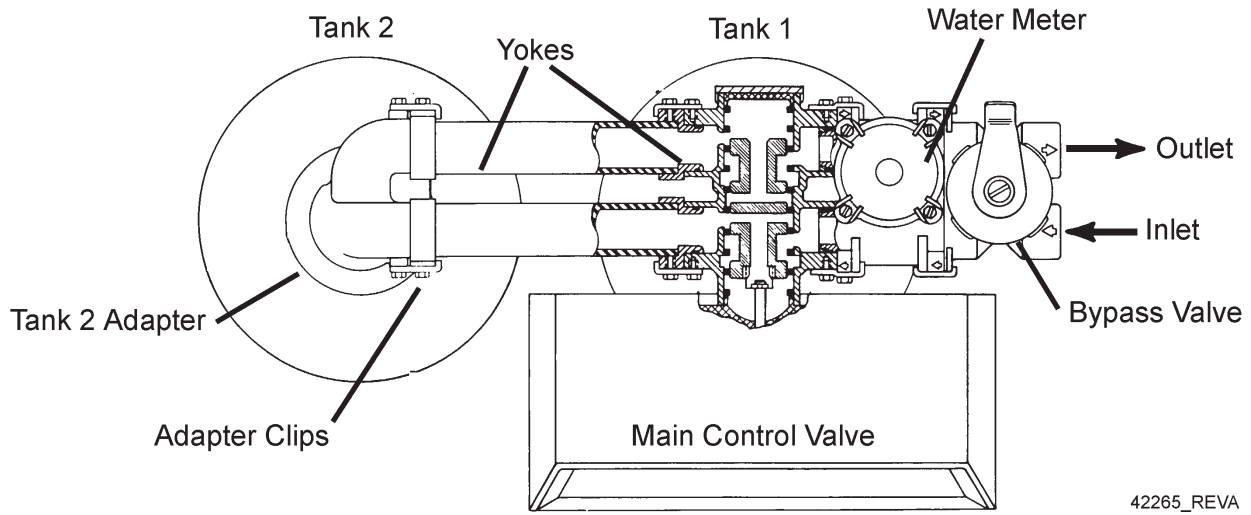

9500 Equipment Configuration

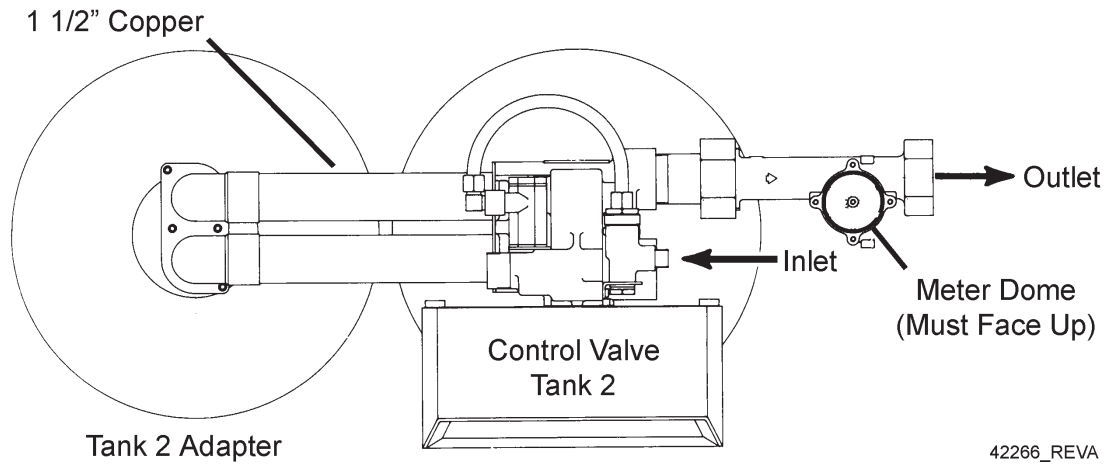

General and Commercial Installation Checklist

1. Place the softener tank where you want to install the unit.
NOTE: Be sure the tank is level and on a firm base.
2. During cold weather it is recommended that the installer warm the valve to room temperature before operating.
3. Perform all plumbing according to local plumbing codes.
 - Use a 1/2" minimum pipe size for the drain.
 - Use a 3/4" drain line for backwash flow rates that exceed 7 gpm or length that exceeds 20' (6 m).
4. Both tanks must be the same height and diameter and filled with equal amounts of media.
5. The distributor tube must be flush with the top of each tank. Cut if necessary. Use only non-aerosol silicone lubricant.
6. Lubricate the distributor o-ring seal and tank o-ring seal. Place the main control valve on one tank and the tank adapter on the second tank.
NOTE: If required, solder copper tubing for tank interconnection before assembling on the main control valve and tank adapter. Maintain a minimum of 1" distance between tanks on final assembly.
7. Solder joints near the drain must be done before connecting the Drain Line Flow Control fitting (DLFC). Leave at least 6" (152 mm) between the DLFC and solder joints when soldering pipes that are connected on the DLFC. Failure to do this could cause interior damage to DLFC.
8. Use only Teflon tape on the drain fitting.
9. Be sure the floor under the salt storage tank is clean and level.
10. Place approximately 1" (25 mm) of water above the grid plate. If a grid is not utilized, fill to the top of the air check in the salt tank. Do not add salt to the brine tank at this time.
11. On units with a bypass, place in Bypass position.
 - Turn on the main water supply.
 - Open a cold soft water tap nearby and let water run a few minutes or until the system is free of foreign material (usually solder) resulting from the installation. Close the water tap when water runs clean.
12. Place the bypass In Service position and let water flow into the mineral tank. When water flow stops, slowly open a cold water tap nearby and let water run until air is purged from the unit. Then close tap.

Electrical

13. Make all electrical connections according to codes. Plug the valve into an approved power source. Do not insert meter cable into the meter yet.
14. Tank one has control valve and tank two has adapter.
15. Look on the right side of the control valve, it has indicators showing which position the control valve is in during Regeneration and which tank is In Service.

NOTE: Make sure the meter cable is not inserted in the meter dome. Swing the timer out to expose the program wheel (to swing timer out) grab onto the lower right corner of timer face and pull outward.

General and Commercial Installation Checklist

Control Valve Position Indicators

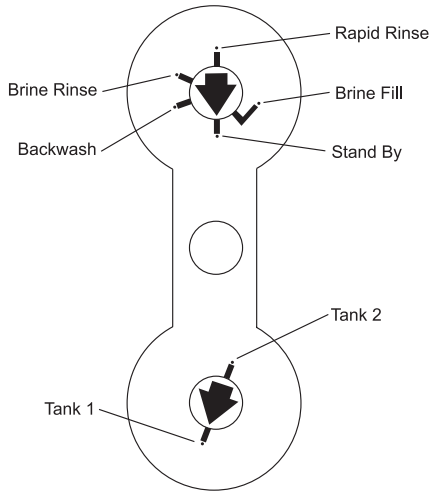

Timer

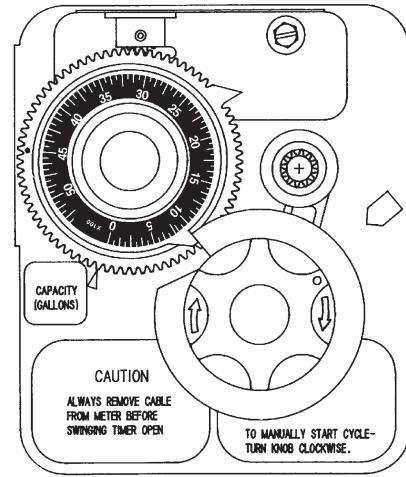

Program Wheel

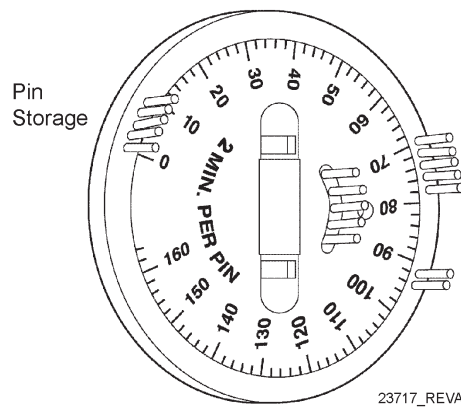

16. Cycle timer into backwash position. Turn manual knob so that the micro switch rides on the first set of pins.
 - In this position the tanks switch (lower piston) and the control valve moves to the backwash position (upper piston).
 - Wait until the positioning of upper and lower pistons stops before advancing the timer further. If advanced too fast the control will not home into the In Service position (it will not advance to any other position). To correct this, rotate the manual knob back to In Service and start again into backwash.
- NOTE:** Once valve positions itself into the backwash cycle, the homing circuit locks in.
17. With all the air backwashed, slowly cycle the timer to the brine position; rapid rinse; and brine tank refill. Wait for the control drive motor to position itself in each cycle and stop, before advancing on to the next position.
18. Once back in the In Service position, cycle the control valve again into the backwash position. The tanks switch again, and air head backwashes out of the other tank. Cycle the control back to the In Service position. Leave the timer in the open position. **DO NOT** insert meter cable yet.

NOTE: Two motors are available.
1/15 RPM has 82 minute regeneration time.
1/30 RPM has 164 minute regeneration time.

General and Commercial Installation Checklist

WATER PRESSURE: A minimum of 25 pounds of water pressure is required for regeneration valve to operate effectively.

ELECTRICAL FACILITIES: A continuous 115 volt, 60 Hertz current supply is required. Make certain the current supply is always hot and cannot be turned off with another switch.

EXISTING PLUMBING: Condition of existing plumbing should be free from lime and iron buildup. Piping that is built up heavily with lime and/or iron should be replaced. If piping is clogged with iron, a separate iron filter unit should be installed ahead of the water softener.

LOCATION OF SOFTENER AND DRAIN: The softener should be located close to a drain.

BY-PASS VALVES: Always provide for the installation of a by-pass valve.

Valve to Tank Installation Instructions

1. Spin the valve onto the tank, ensuring the threads are not cross-threaded.
NOTE: All Fleck® valves are right-hand threads, or clockwise, to install
2. Rotate the valve freely without using force until it comes to a stop (this position is considered zero).
3. Rotate the valve clockwise from zero, between ¼ turn and ½ turn (see the diagram below).

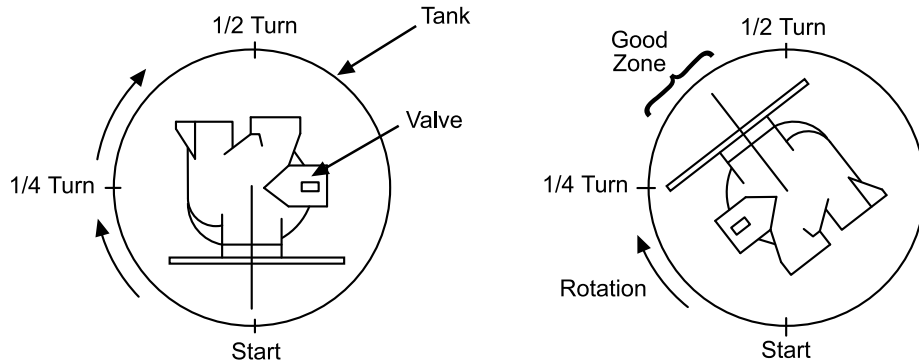

NOTE: If lubricant is required, a silicone compound is strongly recommended. Dow Corning® Silicone Compound (available from Fleck®), is recommended for best possible results. Dow Corning® 7 Release Compound is used in the manufacture of Fleck® control valves. The use of other types of lubricants may attack the control's plastic or rubber components. Petroleum-based lubricants can cause swelling in rubber parts, including o-rings and seals.

Part No.	Description
16174	Silicone, 2 oz Tube
16586-8	Silicone, Dow #7 8 LB

	<p>CAUTION</p> <ul style="list-style-type: none">• Do Not Exceed Water Pressure of 125 psi.• Do Not Exceed 110° F.• Do Not Subject Unit to Freezing Conditions.
--	--

Regeneration Cycle Program Setting Procedure

Setting the Regeneration Cycle Program

The Regeneration cycle program on the water conditioner is preset at the factory. However, portions of the cycle or program time may be lengthened or shortened for local conditions or system design.

1. Expose cycle program wheel by grasping timer in lower right hand corner and pulling. This releases snap retainer and swings timer to the left
NOTE: Meter cable must be removed from meter dome before opening timer.
2. Remove the program wheel by grasping program wheel and squeezing protruding lugs towards center. Lift program wheel off timer.
 - Switch arms may require movement to facilitate removal.
3. Return timer to closed position by engaging snap retainer in back plate.
 - Make certain all electrical wires locate above snap retainer post.

Changing Length of the Backwash Time

Looking at the numbered side of the program wheel, the group of pins starting at zero determines the length of time the unit backwashes.

Example: If there are six pins in this section, the time of backwash is 12 minutes (2 minutes per pin). To change the length of backwash time, add or remove pins as required.

- The number of pins multiplied by two equals minutes of backwash.

Changing Length of Brine and Rinse Time

The group of holes between the last pin in the backwash section and the second group of pins determines the length of time that a unit will brine and rinse (2 minutes per hole).

To change the length of brine and rinse time, add or remove pins in the rapid rinse group of pins to increase or decrease the number of holes in the brine and rinse section.

- The number of holes multiplied by two equals minutes of brine and rinse.

Changing Length Of Rapid Rinse

The second group of pins on the program wheel determines the length of time the water conditioner rapid rinses (2 minutes per pin). To change the length of rapid rinse time, add or remove pins at the higher numbered end of this section as required.

- The number of pins multiplied by two equals minutes of rapid rinse.

NOTE: Program wheels with 0–82 minute cycle times, use one minute per pin or hole to set Regeneration times. The layout of pins and holes on the program wheel follow the same procedure as on this page.

Changing Length of Brine Tank Refill Time

The second group of holes on the program wheel determines the length of time the water conditioner refills the brine tank (2 minutes per hole).

To change the length of refill time, move the two pins at the end of the second group of holes as required.

The Regeneration cycle is complete when the two pin set at end of the brine tank refill section trips the outer micro-switch. The program wheel, however, continues to rotate until the inner micro-switch drops into the notch on the program wheel.

Programming

1. The control valve is set at the factory for backwash; brine and slow rinse; rapid rinse and brine tank fill times. Change any of these times by repositioning the pins and holes or adding more pins.

NOTE: Two speed timer motors are available

1/15 RPM has 82 minute Regeneration Time and each pin or hole equals one minute.

1/30 RPM has 164 minute Regeneration Time and each pin or hole equals two minutes.

Time Brine Refill and Meter Setting Procedure

2. The control valve has a separate brine tank fill cycle.
- Calculate the desired salt setting using the brine line flow control rate of refill (in gpm) multiplied by the timer setting. Then, using one gallon of fresh water dissolving approximately 3 lbs salt, calculate the refill time.

Example: A desired 30 lbs salt setting:

The unit has a 1.0 gpm refill rate so a 10 gallon fill is required.

$$10 \text{ gallons} \times 3 \text{ lbs/gals} = 30 \text{ lbs salt}$$

Set the timer refill section at 10 minutes.

$$10 \text{ minutes} \times 1.0 \text{ gpm} = 10 \text{ gallon fill}$$

NOTE: There must always be two pins at the end of a refill time to stop the fill cycle. With the Regeneration times set, place timer back to its original position, making sure the lower right hand corner snaps back into the backplate and the meter cable slides through the backplate and does not bind.

3. Setting the gallon wheel.

Knowing the amount of resin in each tank and the salt setting per Regeneration, calculate the gallons available, using the following capacities as a guide:

$$\frac{(\text{capacity per ft}^3 \times \text{ft}^3 \text{ of resin per tank})}{\text{compensated hardness of H}_2\text{O}} = \text{gallons available}$$

NOTE: Based on tank size:

More resin increases capacity, less resin decreases capacity.

More salt increases capacity, less salt decreases capacity.

Example:

Tank Diameter	=	16"
Compensated Hardness	=	35 grains per gallon (tested sample)
ft ³ Resin (based on flow rate)	=	4
lbs of Salt	=	8
Capacity per ft ³	=	24,000

$$\frac{(24,000 \times 4 \text{ ft}^3 \text{ of resin per tank})}{35 \text{ grains}} = 2,740 \text{ gallons available before regeneration}$$

DO NOT SET THIS FIGURE - GO TO STEP 4

- Because the control valve regenerates with soft water from the other tank, subtract the water used for regeneration. Take each regeneration cycle and calculate the water used.

Example: Unit is set for a 16" diameter tank with 4 ft³ of resin and salted at 8 lbs. per ft³, 7 gpm backwash, #3 injector, 1.0 gpm brine refill, and 60 psi and timer set for 10 min. backwash, 60 min. brine and rinse, 10 min. rapid rinse, 10 min. brine tank fill.

Backwash	10 minutes x 7.0 gpm =	70.0 gallons
Brine and Rinse	60 minutes x 1.0 gpm =	60.0 gallons
Rapid Rinse	10 minutes x 7.0 gpm =	70.0 gallons
Brine Tank Fill	10 minutes x 1.0 gpm =	10.0 gallons
Total Regeneration Water =		210.0 gallons

With the 2740 gallons available calculated in Step 3, subtract the Regeneration water used from the total water available.

2740 gallons available - 210 gallons used = 2530 gallons
(in Regeneration, Step 4)

Time Brine Refill and Meter Setting Procedure

4. Set meter wheel at approximately 2530 gallons. Lift the inner dial of the meter program wheel so that you can rotate it freely. Position the white dot opposite the 2530 gallon setting.

NOTE: There is a slight delay between the time the meter zeros out and the cycle starts. Units using the:
1/15 RPM motor, 82 minute Regeneration Time has a 9 minute delay
1/30 RPM motor, 180 minute Regeneration Time has an 18 minute delay.

NOTE: This delay period is not critical on residential equipment. However, take this factor into consideration for commercial applications by subtracting continuous flows for 9 minutes or 18 minutes from water available.

5. Insert meter cable into meter.
6. Check bypass.
7. Plug in unit.

9000/9100/9500 (3200 Series)

Electro Mechanical Timer Assembly

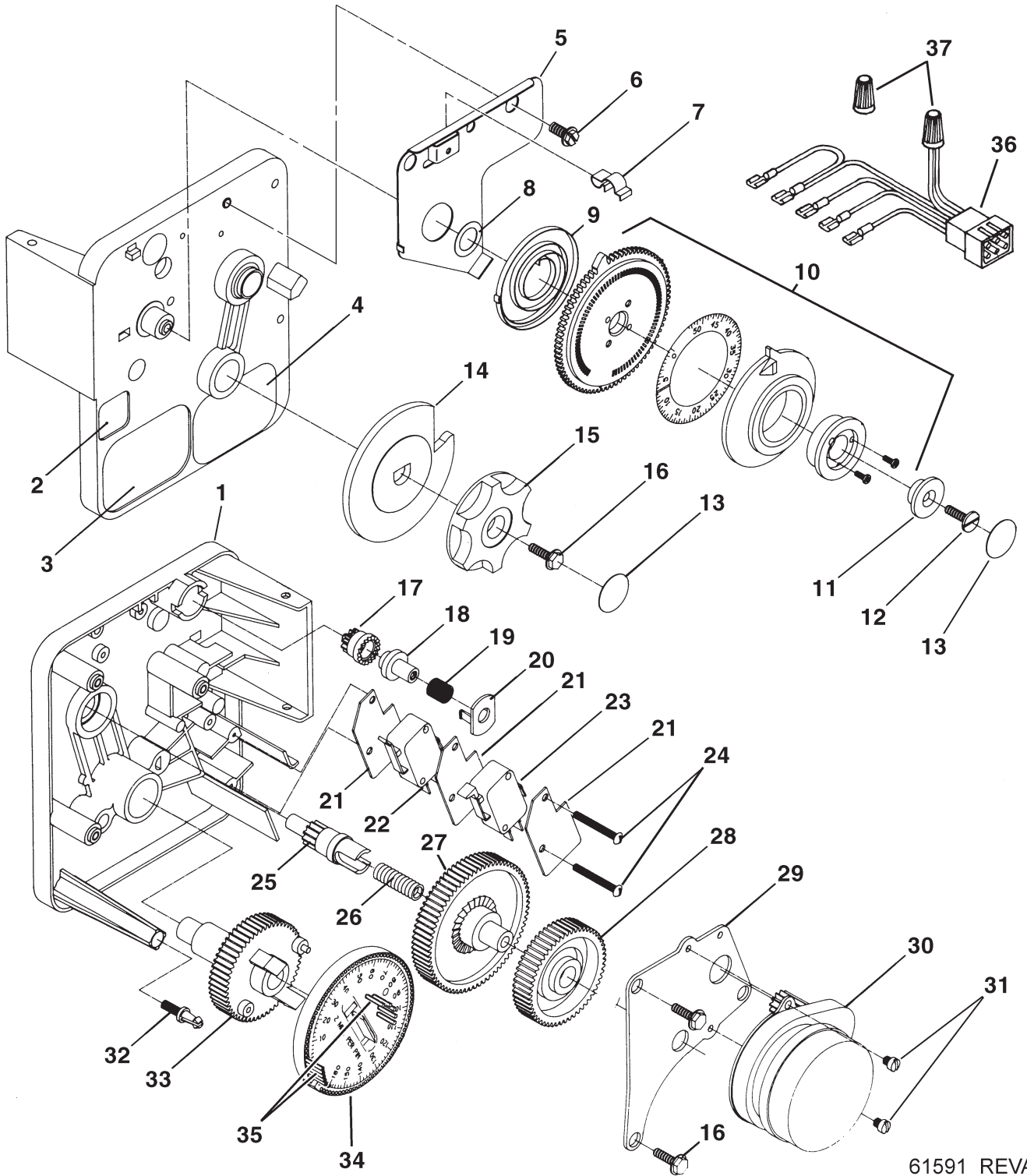

61591_REVA

For Service Assembly Numbers, See the Back of this Manual

9000/9100/9500 (3200 Series)

Electro Mechanical Timer Assembly

Item No.	Quantity	Part No.	Description
1.....	1.....	13870-03.....	Housing, Timer, 9000
2.....	1.....	17870.....	Label, Indicator, 9000 Timer
3.....	1.....	15465.....	Label, Caution
4.....	1.....	16930.....	Label, Instruction
5.....	1.....	15227.....	Plate, Clutch, Actuator
6.....	1.....	10300.....	Screw, Slot Hex Wsh, 18-8 x 3/8
7.....	1.....	17513.....	Clip, Spring
8.....	1.....	15407.....	Washer, Plain, #4
9.....	1.....	15228.....	Spring, Return
10.....	1.....	16270-10.....	Program Wheel Assy, 9000 3/4
		16270-50.....	Program Wheel Assy, 9000/9500
		16270-30.....	Program Wheel Assy, 9000, 1" Std
		16270-40.....	Program Wheel Assy, 9000, 1" Ext
		16270-50.....	Program Wheel Assy, 9000/9500
		16270-60.....	Program Wheel Assy, 9500
11.....	1.....	13806.....	Retainer, Program Wheel
12.....	1.....	13748.....	Screw, Flt Hd St, 6-20 x 1/2
13.....	2.....	11999.....	Label, Button
14.....	1.....	15223.....	Actuator, Cycle
15.....	1.....	13886.....	Know, 3200
16.....	4.....	13296.....	Screw, Hex Wsh, 6-20 x 1/2
17.....	1.....	17724.....	Program Wheel, Pinion Drive
18.....	1.....	17723.....	Clutch, Drive Pinion
19.....	1.....	14276.....	Spring, Meter Clutch
20.....	1.....	14253.....	Retainer, Clutch Spring
21.....	3.....	14087.....	Insulator
22.....	1.....	15314.....	Switch, Micro, Modified
23.....	1.....	15320.....	Switch, Micro, Timer
24.....	2.....	11413.....	Screw, Pan Hd Mach, 4-40 x 1 1/8
25.....	1.....	13018.....	Pinion, Idler
26.....	1.....	18563.....	Spring, Idler Shaft
27.....	1.....	13017.....	Gear, Idler
28.....	1.....	13164.....	Gear, Drive
29.....	1.....	13887.....	Plate, Motor Mounting
30.....	1.....	18743.....	Motor, 120V, 60 Hz 1/30 RPM, 5600
		18824-1.....	Motor, 230V, 50 Hz 1/30 RPM
		19170.....	Motor, 120V 60 Hz 1/15 RPM
		18825.....	Motor, 230V, 50 Hz 1/15 RPM Mallory
31.....	2.....	13278.....	Screw, Phil Hd Mach, 6-32 x 1/8 Steel Zinc
32.....	1.....	14265.....	Clip, Spring
33.....	1.....	15055.....	Timer, Main Drive Gear
34.....	1.....	19210-02.....	Program Wheel Assy, 9000 1/15
		19210-05.....	Program Wheel Assy, 9000/3230
35.....	23.....	15493.....	Pin, Spring, 1/16 x 5/8 SS
36.....	1.....	15203.....	Harness, 9000/9500, Timer
37.....	2.....	40422.....	Nut, Wire, Tan
Not Shown ...	1.....	60320-02.....	Switch Kit, 3200/9000 Timer Auxiliary

For Service Assembly Numbers, See the Back of this Manual

Power Head Assembly

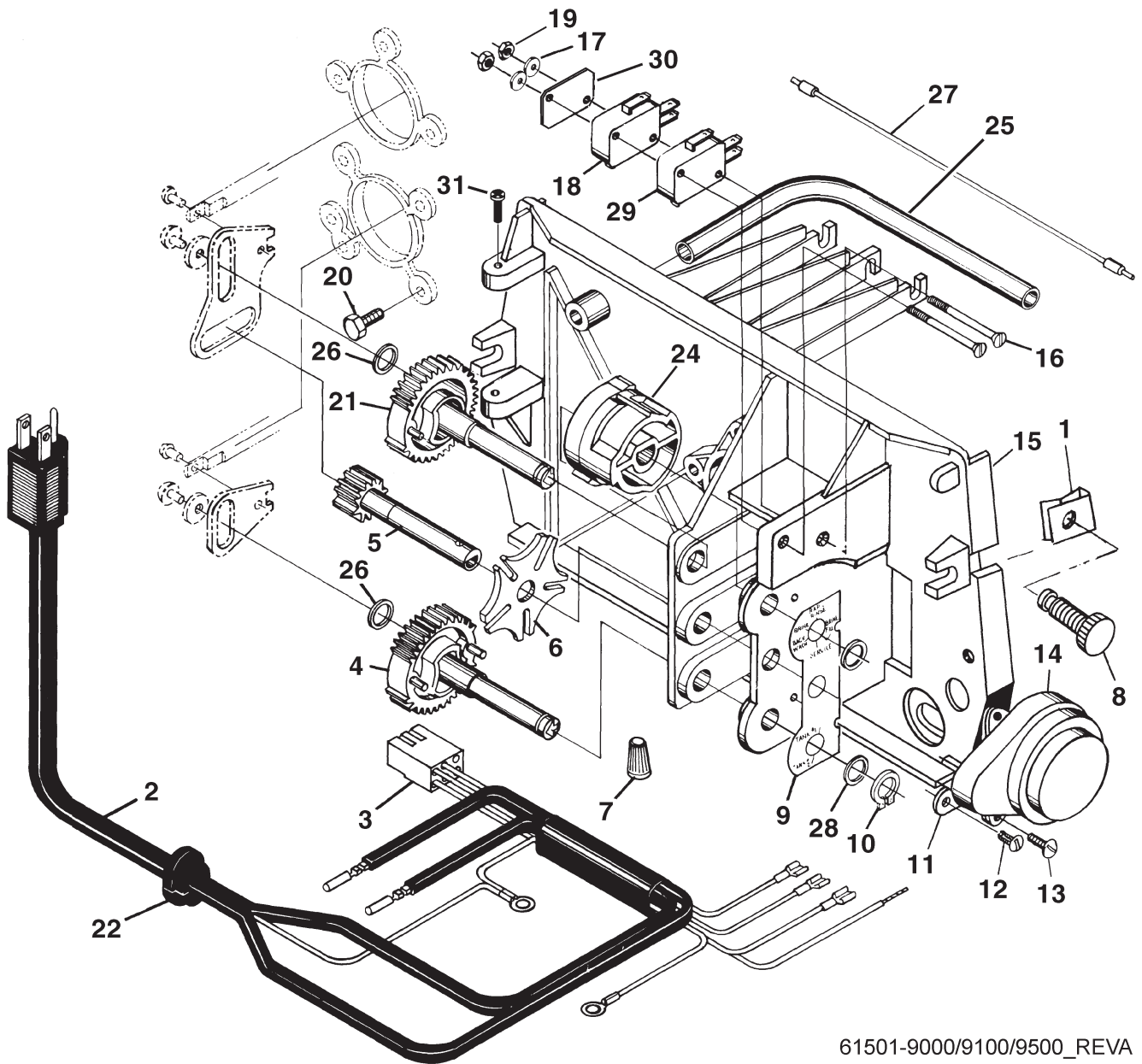

61501-9000/9100/9500_REVA

For Service Assembly Numbers, See the Back of this Manual

Power Head Assembly

Item No.	Quantity	Part No.	Description
1	2	18728	Nut, Tinnerman, U Type, 8-32
2	1	11838	Power Cord, 6' Fleck
		11839	Power Cord, 12' Fleck
		40084-12	Power Cord, 12' U.S., Round, 120V Sys 5, 6, 7 & 2900/3150/3900 #4
		11545-01	Power Cord Assy, 4' Black, Euro w/Terminals
		14678	Power Cord, U.S., 220/60
		19303-01	Power Cord Assy, Australian w/Terminals
		40085-12	Power Cord, 12' US, Round, 240V
		19674	Transformer, 24V, 9.6VA Residential Valves
		41475	Transformer, 24V, 9.6VA, European
3	1	15202	Harness, 9000/9500, Drive
		14822	Harness, 2900
		40041-06	Harness, Low V, 9000/9500
4	1	15134	Gear Assy, Drive, 1/2" Stroke 9000/9500
5	1	15135	Gear, Drive, 9000
6	1	14896	Wheel, Geneva
7	2	40422	Nut, Wire, Tan
8	2	19367	Screw, Designer Cover, Thumb 8-32 Blank UV Stable Material
9	1	15175	Label, Shaft Position
10	2	14917	Ring, Retaining
11	1	15199	Plate, Ground, 9000/9500
12	1	14430	Screw, Hex Wsh St, 6 x 1/4 Type "B"
13	2	19160	Screw, Phil Pan, Thread 6-32 x 3/8 Type 23 Zinc
14	1	18737	Motor, 24V, 50/60 Hz, 1 RPM
		18738	Motor, 120V, 50/60 Hz 1 RPM
		18739	Motor, 220V, 50/60 Hz 1 RPM
15	1	15131	Backplate, 9000
		17784-05	Panel, Control, 9000/9500 ET
16	2	15172	Screw, Flt Hd Mach, 4-40 x 1 3/8 Steel Zinc Plate
17	2	10340	Washer, Lock #4, Zinc
18		10218	Switch, Micro
19	1	10339	Nut, Hex, 4-40 Zinc Plated
20	1	15331	Screw, Hex Wsh Mach, 10-24 x 3/4 410 S.S.
21	2	15133	Gear Assy, Drive, 3/4" Stroke
22	1	13547	Strain Relief, Flat Cord Heyco #30-1
23	1	15810	Ring, Retaining
24	1	15132	Cam, Triple
		17331	Cam, 9500
		17765	Cam Assy, Aux Switch, 9500
25	1	15368	Tube, Cable Guide, 2-Tank
		17337	Tube, Cable Guide, 9500
26	2	15372	Washer, Thrust, 3/8
27	1	15216	Meter Cable Assy, 15.25"
		15425	Meter Cable, 13.25"
		17744	Meter Cable Assy, 20.75" 1 1/2" Std
		19121-01	Meter Cable Assy, SE, Paddle 6600/6700
		19121-05	Meter Cable Assy, ET, 28" 2750/3150 Systemax 4-6
		19791-01	Meter Cable Assy, Turbine/SE
28	2	15692	Washer, Plain, 3/8"
29	1	16433	Switch, Miniature
30	1	10302	Insulator, Limit Switch
31	2	15173	Screw, Slot Rd Hd Mach, 5-20 x 3/8
		Not Shown	
	1	60232-110	Cover, Designer, 1 Pc Black
	1	60232-112	Cover, Designer, 1 Pc Black w/Left Window
	1	60320-09	Switch Assy, 9000, Drive Cam
	1	60320-10	Switch Assy, 9500, Drive Cam

For Service Assembly Numbers, See the Back of this Manual

9000 Control Valve Assembly

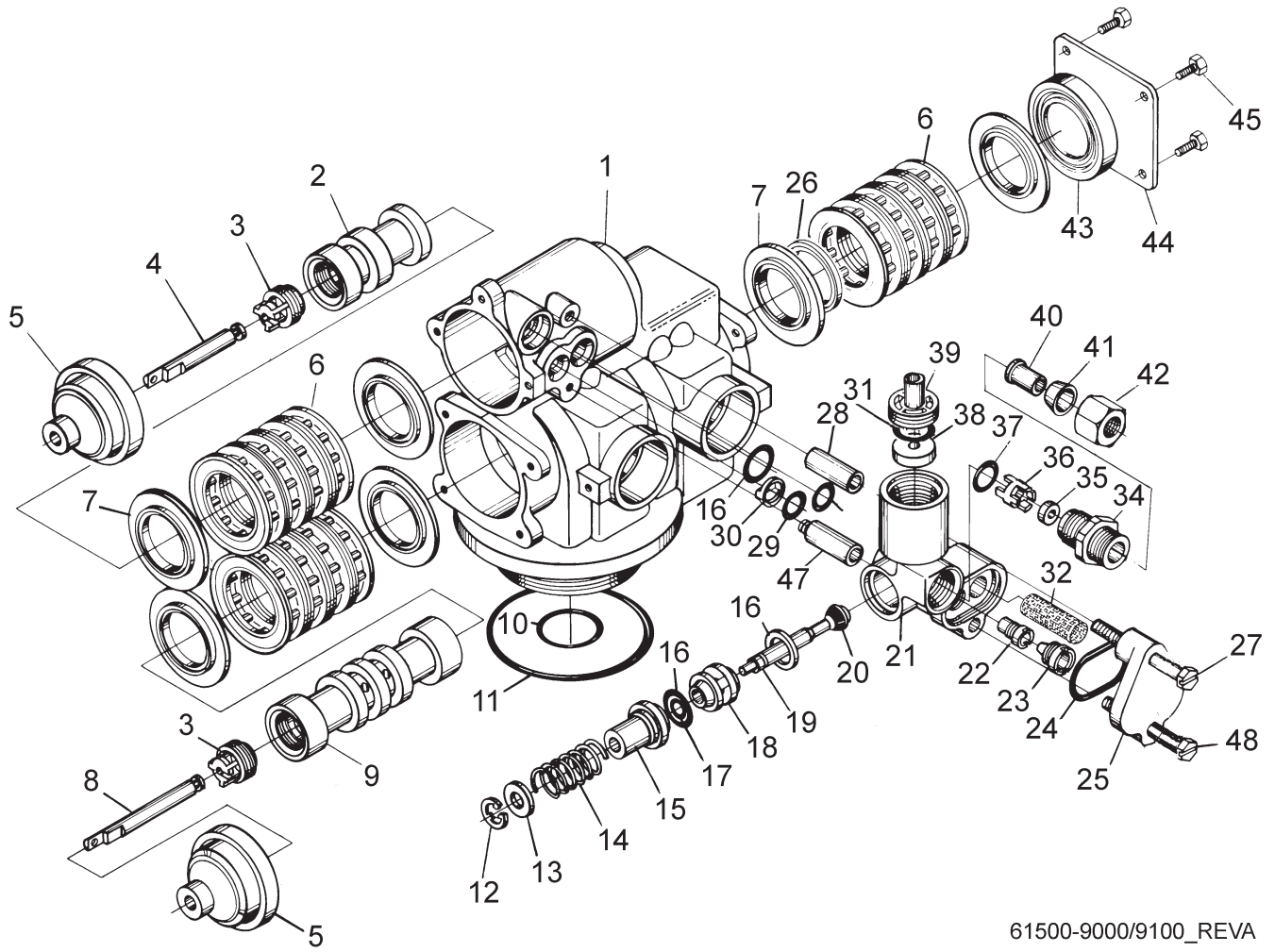

61500-9000/9100_REVA

For Service Assembly Numbers, See the Back of this Manual

9000 Control Valve Assembly

Item No.	Quantity	Part No.	Description
1	1	14861-01	Valve Body, 9000, Machined w/O-ring
		40688	Valve Body, 9100
2	1	14914	Piston, 9000, Upper
3	2	14309	Retainer, Piston Rod
		16590	Retainer, Piston Rod
4	1	14919	Rod, Piston, Upper
5	2	13446	End Plug Assy, White
		13446-01	End Plug Assy, White, HW
6	12	14241	Spacer, 5600
		14241-01	Spacer, Hot Water
7	16	13242	Seal, 5600
		18759	Seal, 5600 Low Drive Force
8	1	14920	Rod, Piston, Lower, 9000
9	1	14905	Piston, 9000
10	1	11710	O-ring, -215
11	1	12281	O-ring, -338
12	1	11981-01	Ring, Retaining
13	1	16098	Washer, Nylon Brine
14	1	11973	Spring, Brine Valve
15	1	13165	Cap, Brine Valve
16	3	13302	O-ring, -014
17	1	12550	Quad Ring, -009
18	1	13167	Spacer, Brine Valve
19	1	14925	Brine Valve Stem, 9000
20	1	12626	Seat, Brine Valve
21	1	15215	Body, Injector, 9000
22	1	10914-X	Injector Throat - Specify Size
23	1	10913-X	Injector Nozzle - Specify Size
		10225-X	Injector Nozzle, SS
24	1	13303	O-ring, -021
25	1	13166	Cap, Injector, 5600
26	1	16595	Spacer, 9000
27	1	13387	Screw, Hex Hd Mach, 10-24 x 1 3/4
28	1	13361	Spacer, 4650/9000
29	2	13301	O-ring, -011, Injector
30	1	13497	Disperser, Air, 5600
31	1	15348	O-ring, -563
32	1	10227	Screen, Injector
34	1	13244	Adapter, BLFC
35	1		Button, BLFC - Specify Size
36	1	13245	Retainer, BLFC
		12977	O-ring, -015
38	1		Button, DLFC - Specify Size
39	1	13173	Retainer, DLFC Button
40	1	10332	Fitting, Insert, 3/8
		15415*	Fitting, Insert, 1/2" Tube
41	1	10330	Fitting, Sleeve, 3/8 Celcon
		16124*	Fitting, Sleeve, Delrin
42	1	10329	Fitting, Tube, 3/8 Nut, Brass
		16123*	Nut, Brass
43	1	14928	Plug, End Stub, 9000
44	1	14906	Plate, End, 9000
45	4	15137	Screw, Hex Wsh Mach 10-24 x 3/8
47	1	13387	Screw, Hex Hd Mach, 10-24 x 1 3/4
		13361	Spacer, 4650/9000
48	1	13315	Screw, Hex Wsh Hd, 10-24 x 1 3/16
Not Shown	1	16140	Fitting, 1/2T x 1/4 NPT

NOTE: For Hot Water delete items 41 & 42 and use 18698 (Nut, 3/8 Tube, w/Sleeve) and 15414 (Nut, 2900, w/Sleeve)

*These parts are used with #4 injector and 2 GPM or larger BLFC (Items 34, 35, and 36 are not used).

For Service Assembly Numbers, See the Back of this Manual

9100 Control Valve Assembly

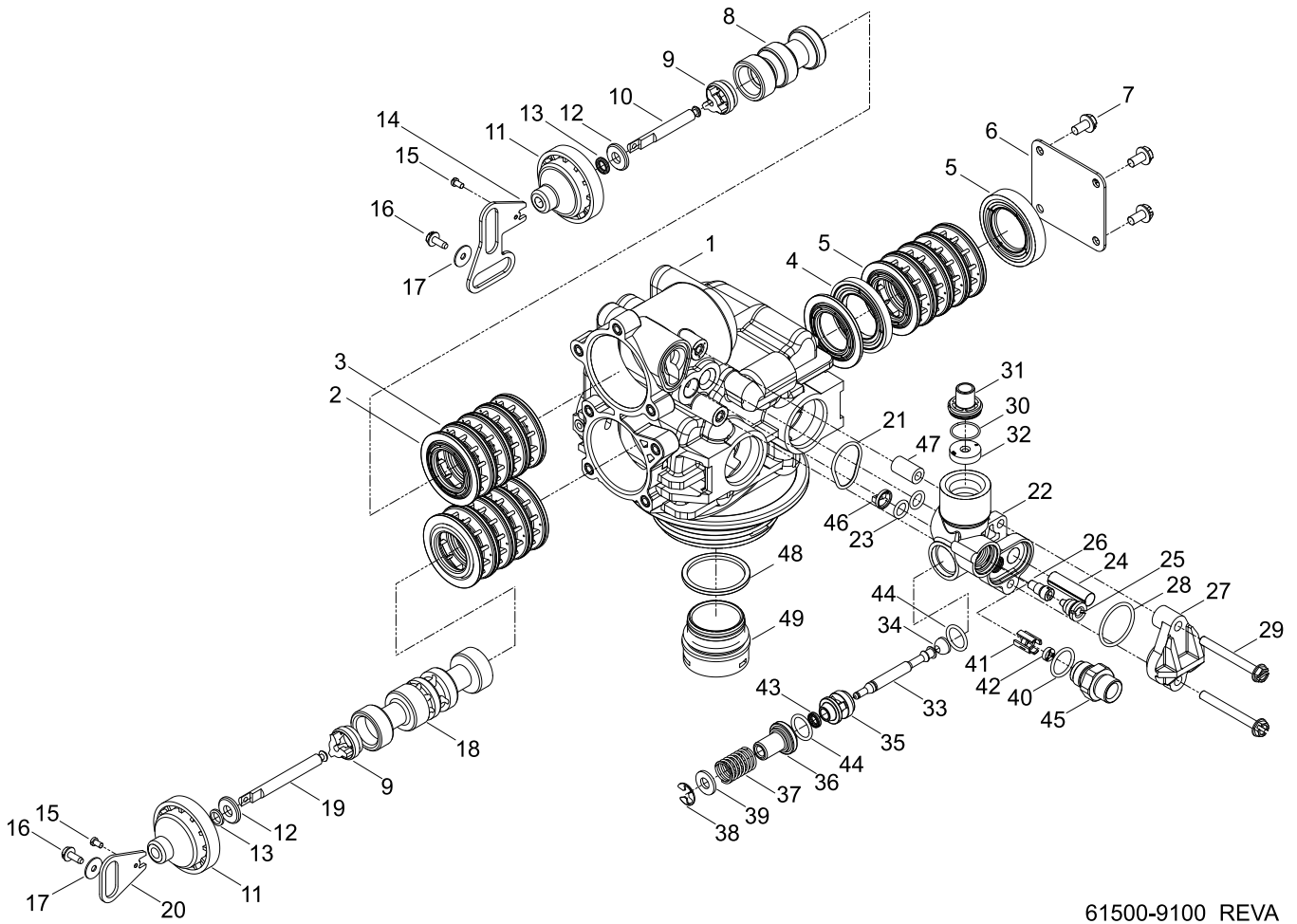

61500-9100_REVA

For Service Assembly Numbers, See the Back of this Manual

9100 Control Valve Assembly

Item No.	Quantity	Part No.	Description
1.....	1.....	40688.....	Valve Body Assy, 9100
2.....	16.....	13242.....	Seal, 5600
3.....	12.....	14241.....	Spacer, 5600
4.....	1.....	16595.....	Spacer, 9000
5.....	1.....	14928.....	Plug, End Stub, 9000
6.....	1.....	14906.....	Plate, End, 9000
7.....	4.....	15137.....	Screw, Hex Wsh Mach, 10-24 x 3/8
8.....	1.....	14914.....	Piston, 9000, Upper
9.....	2.....	14309.....	Retainer, Piston Rod
10.....	1.....	14919.....	Rod, Piston, Upper
11.....	2.....	13243.....	Plug, End, 5600
12.....	2.....	13008.....	Retainer, End Plug Seal
13.....	2.....	10209.....	Quad Ring, -010
14.....	1.....	14921.....	Link, Piston Rod
15.....	2.....	11335.....	Screw, Slot Phil Hd, 4-40 x 3/16
16.....	2.....	17020.....	Screw, Slot Ind Hex, 6-20 x 3/8
17.....	2.....	13363.....	Washer, Plain, .145 ID SS
18.....	1.....	14905.....	Piston, 9000
19.....	1.....	14920.....	Rod, Piston, Lower, 9000
20.....	1.....	15019.....	Link, Piston Rod, 9000/9500
21.....	1.....	41500.....	O-ring, Drain, 9100
22.....	1.....	15215.....	Body, Injector, 9000
23.....	2.....	13301.....	O-ring, -011, Injector
24.....	1.....	10227.....	Screen, Injector
25.....	1.....	10913-1.....	Nozzle, Injector, #1, White
26.....	1.....	10914-1.....	Throat, Injector, #1, White
27.....	1.....	13166.....	Cap, Injector, 5600
28.....	1.....	13303.....	O-ring, -021
29.....	2.....	13387.....	Screw, Hex Hd Wash, 10-24 x 1 3/4
30.....	1.....	15348.....	O-ring, -563
31.....	1.....	13173.....	Retainer, DLFC Button
32.....	1.....	12085.....	Washer, Flow, 1.2 GPM
33.....	1.....	14925.....	Brine Valve Stem, 9000
34.....	1.....	12626.....	Seat, Brine Valve
35.....	1.....	13167.....	Spacer, Brine Valve
36.....	1.....	13165.....	Cap, Brine Valve
37.....	1.....	11973.....	Spring, Brine Valve
38.....	1.....	11981-01.....	Ring, Retaining
39.....	1.....	16098.....	Washer, Nylon Brine
40.....	1.....	12977.....	O-ring, -015
41.....	1.....	13245.....	Retainer, BLFC
42.....	1.....	129095.....	Washer, Flow, .50 GPM
43.....	1.....	12550.....	Quad Ring, -009
44.....	2.....	13302.....	O-ring, -014
45.....	1.....	13244.....	Adapter, BLFC
46.....	1.....	13497.....	Disperser, Air, 5600
47.....	1.....	13361.....	Spacer, 4650/9000/WCC
48.....	1.....	40538.....	Retainer, 32mm, O-ring Dist, 7000
49.....	1.....	61419.....	Kit, 1.05" Distributor, Adapter
Not Shown.....	1.....	13333.....	Label, Injector, Blank
Not Shown.....	1.....	10759.....	Label, .5 GPM, 1.5 LBS Salt/Min

For Service Assembly Numbers, See the Back of this Manual

9500 Control Valve Assembly

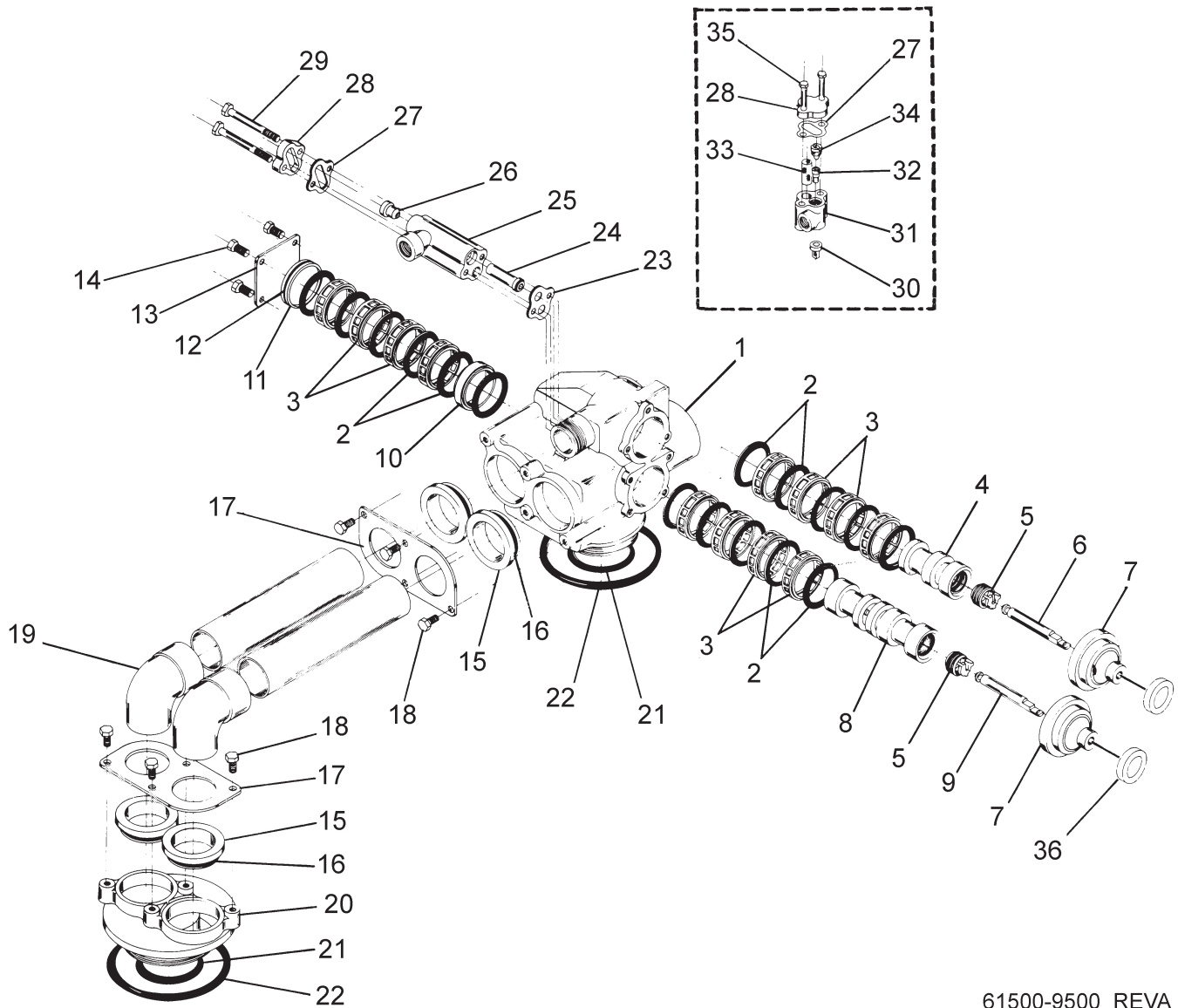

61500-9500_REVA

For Service Assembly Numbers, See the Back of this Manual

9500 Control Valve Assembly

Item No.	Quantity	Part No.	Description
1.....	1.....	16919-01.....	Valve Body, 9500 Machd
2.....	16.....	16101.....	Seal, 2850
3.....	12.....	16638.....	Spacer, 9500/2850
4.....	1.....	17110.....	Piston, 9500, Upper
5.....	2.....	14309.....	Retainer, Piston Rod
6.....	1.....	16957.....	Rod, Piston, 9500
7.....	2.....	17212.....	End Plug Assy, White
		17212-01.....	End Plug Assy, White, HW, 560CD
8.....	1.....	17111.....	Piston, 9500, Lower
9.....	1.....	16956.....	Rod, Piston, Lower
10.....	1.....	17092.....	Spacer, Disc, 9500
11.....	1.....	16955.....	Plug, End, 9500
12.....	3.....	16394.....	O-Ring -029
13.....	1.....	14906.....	Plate, End, 9000
14.....	4.....	41875.....	Screw, Phil Oval HD, #10-24 x 3/8 Mchd
		41876.....	Screw, Phil Oval HD, Mchd M5 x 0.8 x 10MM
15.....	4.....	17052.....	Fitting, Pipe, Coupling
16.....	4.....	17224.....	O-Ring -224
17.....	1.....	17061.....	Retainer, Coupling
18.....	8.....	10231.....	Screw, Slot Hex, 1/4 - 20 x 1/2
		17659.....	Screw, Hex Hd Mach, M6 x 12
19.....	2.....	17353.....	Fitting, Elbow, 1 1/2 x .065
20.....	1.....	16916-01.....	Adapter, 9500, 2nd Tan, Machd w/O-rings
21.....	2.....	13577.....	O-ring -226
22.....	2.....	16455.....	O-ring -347
23.....	1.....	14805.....	Gasket, Injector Body, 1600/1700
24.....	1.....	*14802.....	Throat, Injector
25.....	1.....	17777.....	Body, Injector, 1700
26.....	1.....	*14801.....	Nozzle, Injector
27.....	1.....	10229.....	Gasket, Injector Cap, 1600
28.....	1.....	11893.....	Cap, Injector, SS
29.....	2.....	14804.....	Screw, Hex Hd Mach, 10-24 x 2 3/4
		17655.....	Screw, Hex Hd, M5 x 70
30.....	1.....	16221.....	Dispenser, Air
31.....	1.....	17776.....	Injector, 1600
32.....	1.....	10914-3.....	Throat, Injector, #3, Yellow
33.....	1.....	10227.....	Screen, Injector
34.....	1.....	10913-3.....	Nozzle, Injector, #3, Yellow
35.....	2.....	10692.....	Slot Hex Hd, 10-24 x
		17656.....	Screw, Hex Hd, M5 x 40
36.....	2.....	17558.....	Disc, Spacer, End Plug
Not Shown.....	2.....	19608-15.....	Dispenser, Commercial 1 1/2"
Not Shown.....	1.....	11248.....	Pin, Roll 5/32 x 7/8
Not Shown.....	1.....	60366-XX.....	D.L.F.C. NPT - Specify Size

*Injector Throat	Injector Nozzle	Size	Color
14802-03.....	14801-03.....	#3C.....	Yellow
14802-04.....	14801-04.....	#4C.....	Green
14802-05.....	14801-05.....	#5C.....	White
14802-06.....	14801-06.....	#6C.....	Red

For Service Assembly Numbers, See the Back of this Manual

1600 Brine Valve System (for 9500)

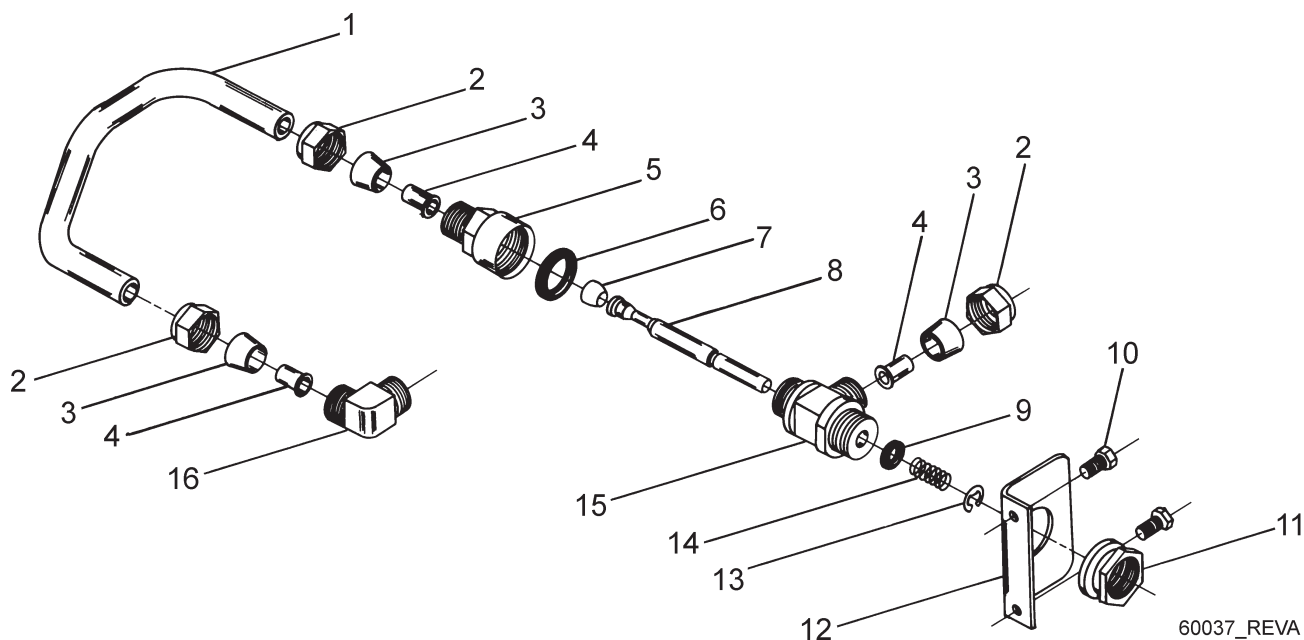

60037_REVA

Item No.	Quantity	Part No.	Description
1.....	1.....	16960.....	Tube, Brine Valve
2.....	1.....	10329.....	Fitting, Tube, 3/8 Nut, Brass
3.....	1.....	10330.....	Fitting, Sleeve, 3/8 Celcon
4.....	1.....	10332.....	Fitting, Insert, 3/8
5.....	1.....	12747.....	Fitting, Flow Control
6.....	1.....	12550.....	Quad Ring, -009
7.....	1.....	12626.....	Seat, Brine Valve
8.....	1.....	16958.....	Brine Valve Stem, 1600 Coated
9.....	1.....	11982.....	O-ring, -016
10.....	3.....	15137.....	Screw, Hex Wsh Mach, 10-24 x 3/8
11.....	3.....	10269.....	Nut, Jam, 3/84 - 16
12.....	3.....	16922.....	Bracket, Brine Valve Mounting
13.....	1.....	10250.....	Ring, Retaining
14.....	1.....	10249.....	Spring, Brine Valve
15.....	1.....	12748-01.....	Brine Valve Body, 1600
16.....	2.....	10328.....	Fitting, Elbow, 90 Deg.

For Service Assembly Numbers, See the Back of this Manual

1700 Brine Valve System (for 9500)

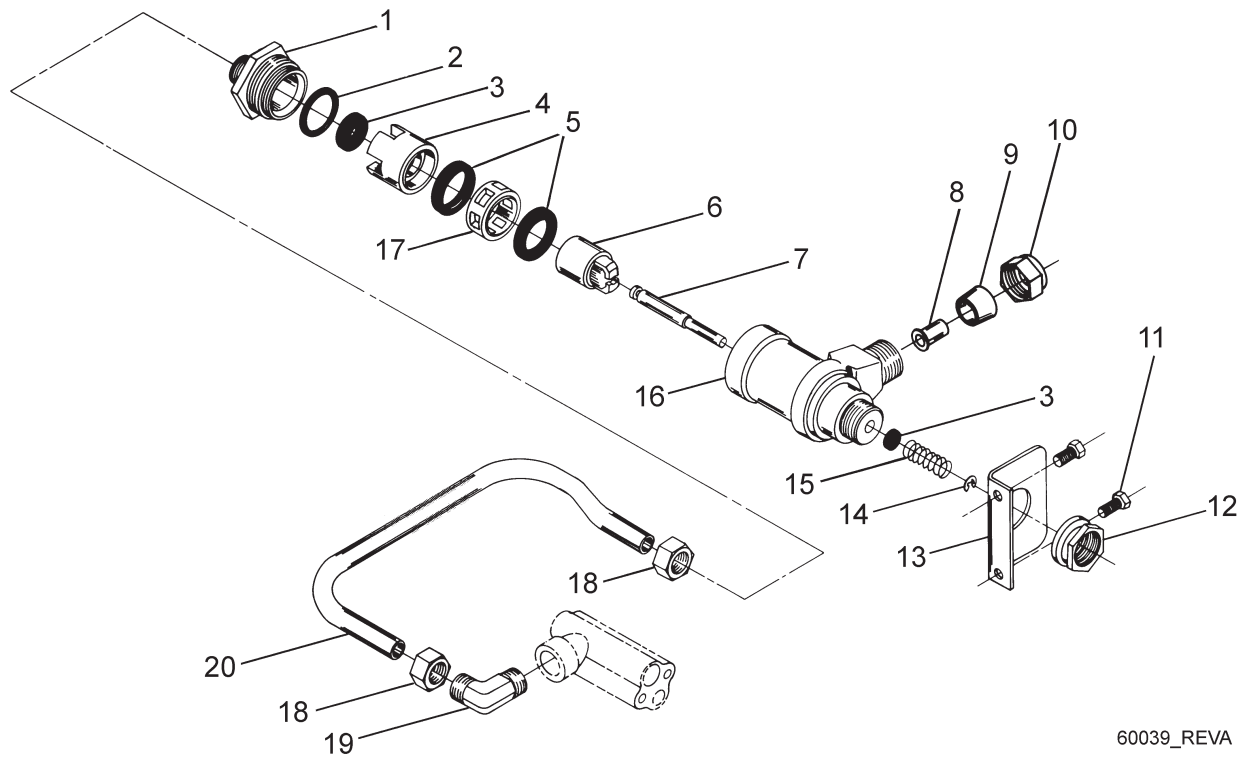

60039_REVA

Item No.	Quantity	Part No.	Description
1.....	1.....	14792.....	Plug, End, Brine Valve
2.....	1.....	13201.....	Quad Ring, -020
3.....	1.....	12550.....	Quad Ring, -009
4.....	1.....	14785-01.....	Retainer, Flow Control
5.....	2.....	14811.....	O-ring, -210, 560CD, Brine
6.....	1.....	14795.....	Piston, Brine Valve
7.....	1.....	16929.....	Brine Valve Stem, Coated
8.....	1.....	15415.....	Fitting, Insert, 1/2" Tube
9.....	1.....	16124.....	Fitting, Sleeve, Delrin
10.....	1.....	16123.....	Nut, Brass
11.....	1.....	15137.....	Screw, Hex Wsh Mach, 10-24 x 3/8
12.....	1.....	10269.....	Nut, Jam, 3/4 - 16
13.....	1.....	16922.....	Bracket, Brine Valve Mounting
14.....	2.....	10250.....	Ring, Retaining
15.....	1.....	15310.....	Spring, Brine Valve
16.....	2.....	14790.....	Brine Valve Body
17.....	1.....	14798.....	Spacer, 1700, Brine
18.....	1.....	15414.....	Nut, 2900, w/Sleeve
19.....	1.....	15413.....	Fitting, Elbow, Male, 1/2T x 3/8 NPT
20.....	1.....	16959.....	Tube, Brine 9500/1710, 10.6"

For Service Assembly Numbers, See the Back of this Manual

9000 Second Tank Assembly

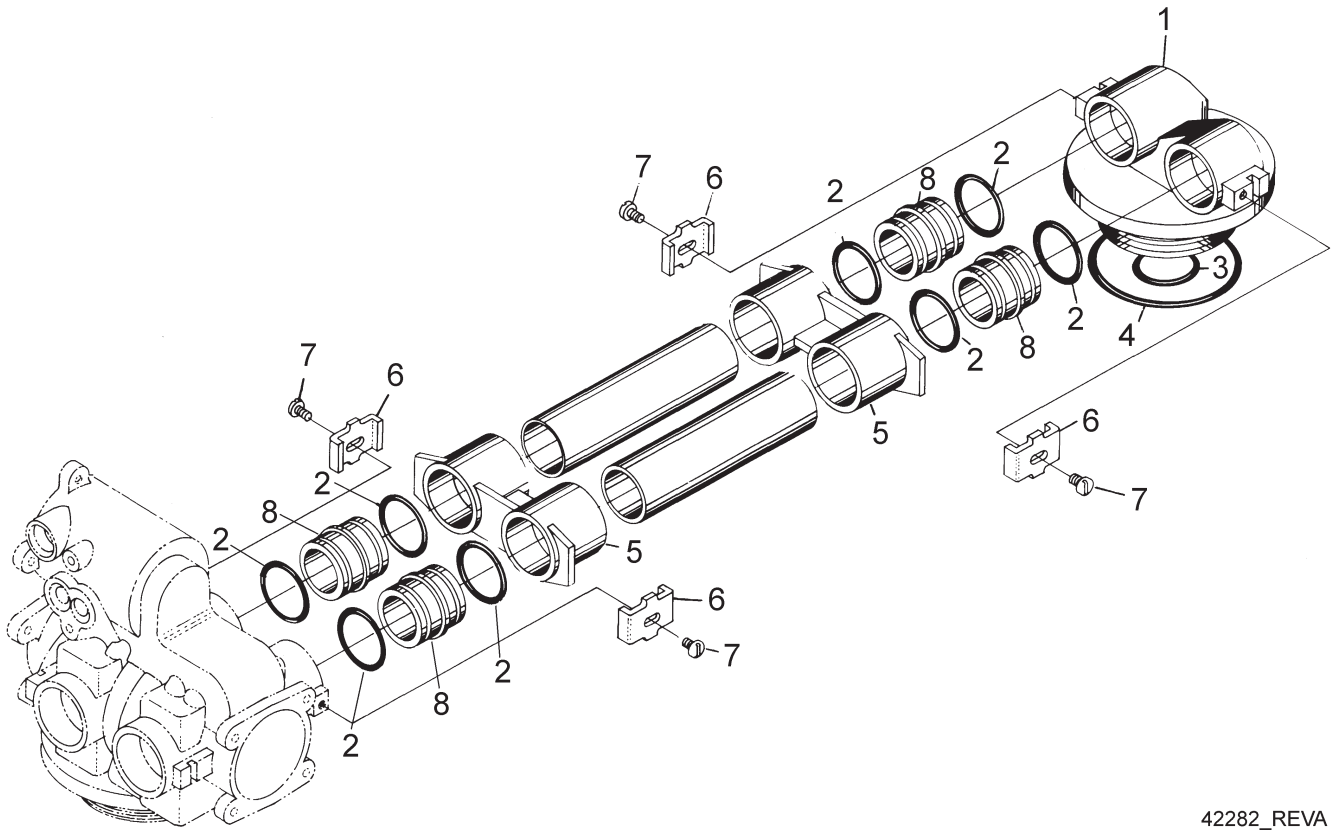

42282_REVA

Item No.	Quantity	Part No.	Description
1.....	1	14864-01	Adapter, 9000, 2nd Tank, Machd w/O-rings
2.....	8	13305	O-ring, -119
3.....	1	11710	O-ring, -215
4.....	1	12281	O-ring, -338
5.....	2	13708-40.....	Yoke, 1" Sweat
.....	1	15823-XX.....	Yoke Assy. Specify Tank Size
6.....	4	13255	Clip, Mounting
7.....	4	14202-01	Screw, Hex Wsh Mach, 8-32 x 5/16
8.....	4	15078	Adapter, 1" Coupling

For Service Assembly Numbers, See the Back of this Manual

9100 Second Tank Assembly

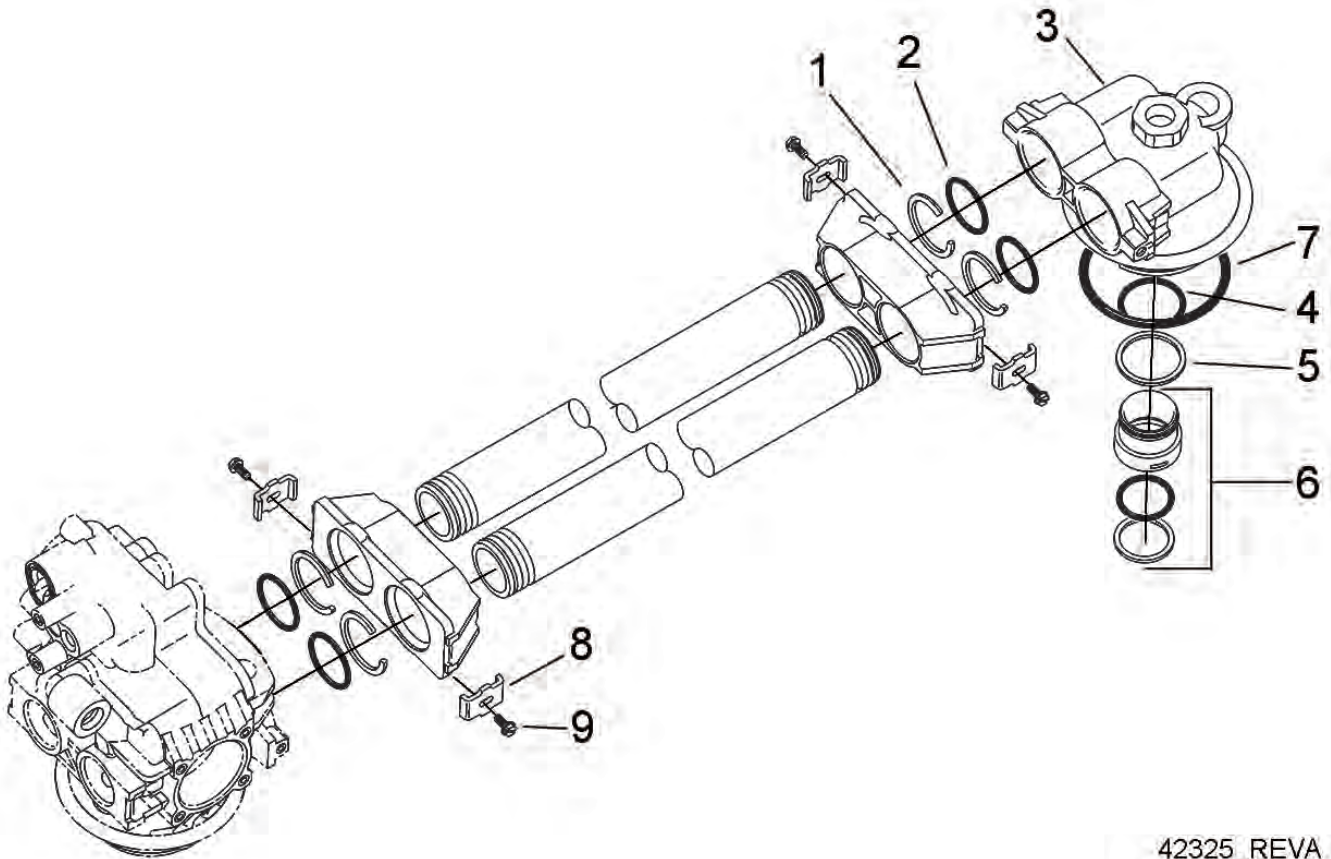

42325_REVA

Item No.	Quantity	Part No.	Description
1	4	40678	Ring, 9100, Yoke Retainer
2	4	13287	O-ring, -123
3	1	14865	Adapter Assy, 2nd Tank, 9100
4	1	19054	O-ring, -124
5	1	40538	Retainer, 32mm, O-ring Dist, 7000
6	1	61419	Kit, 1.05" Distributor, Adapter
7	1	18303	O-ring, -336
8	4	13255	Clip, Mounting
9	4	14202-01	Screw, Hex Wsh Mach, 8-32 x 5/16

For Service Assembly Numbers, See the Back of this Manual

9500 Second Tank Assembly

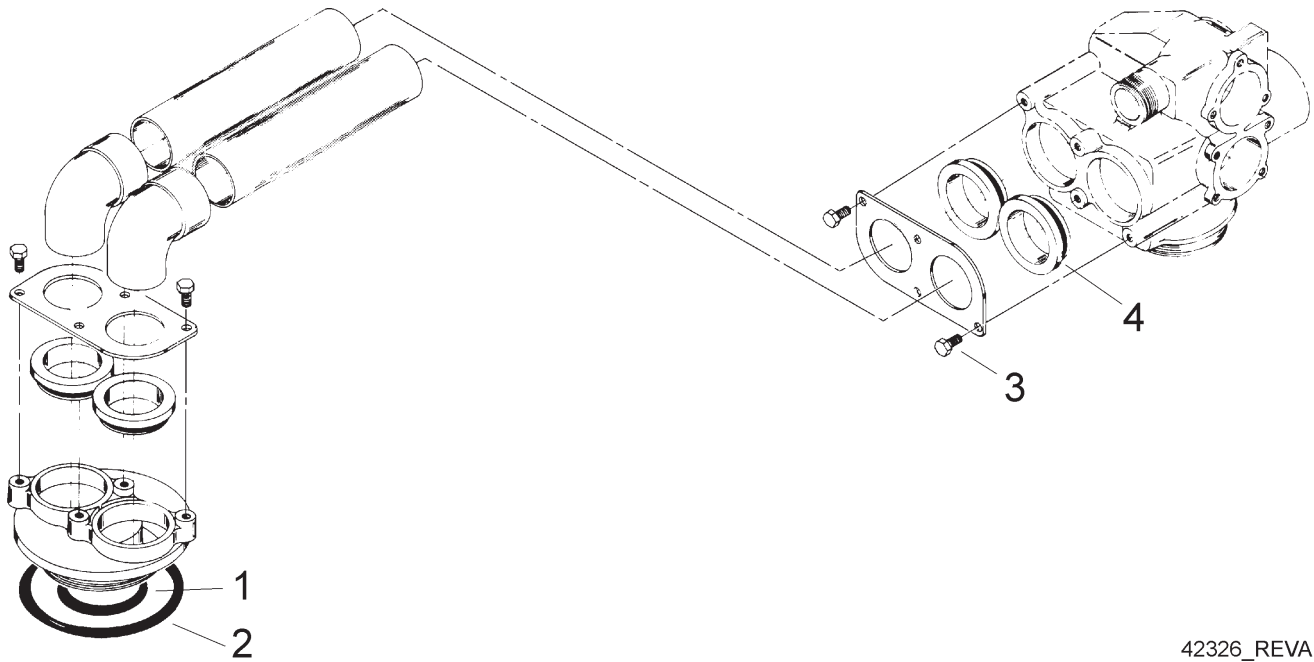

42326_REVA

Item No.	Quantity	Part No.	Description
1.....	1	13577	O-ring, -226
2.....	1	16455	O-ring, -347
3.....	8	10231	Screw, Slot Hex, 1/4 - 20 x 1/2
4.....	4	17224	O-ring, -224

For Service Assembly Numbers, See the Back of this Manual

3/4" Meter Assembly

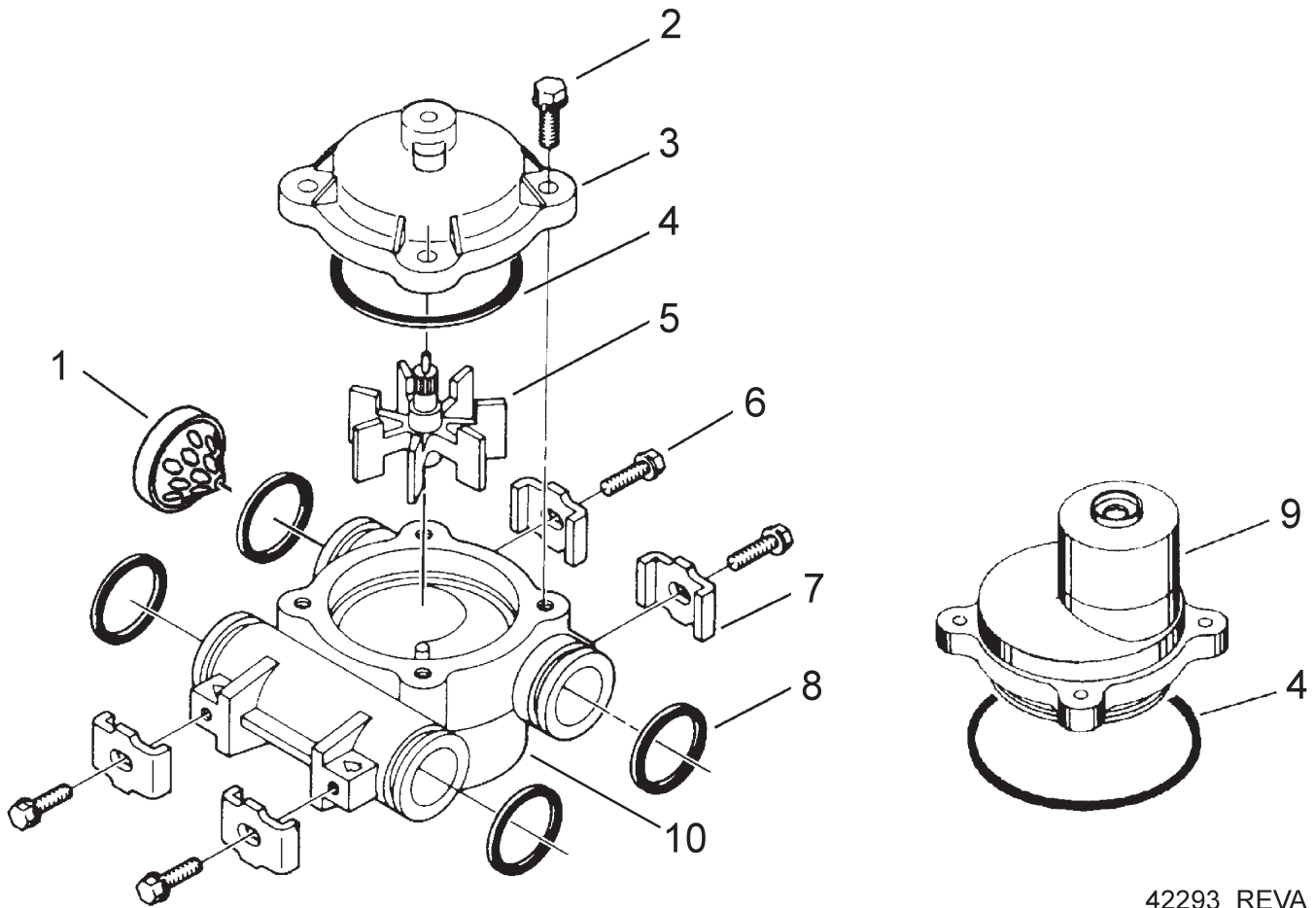

42293_REVA

Item No.	Quantity	Part No.	Description
1.....	1	14613	Flow Straightener
2.....	4	12473	Screw, Hex Wsh, 10-24 x 5/8
3.....	1	14038	Meter Cap Assy
4.....	1	13847	O-ring, -137, Std/560CD, Meter
5.....	1	13509	Impeller, Meter
6.....	4	13314	Screw, Slot Ind Hex, 8-18 x .60
7.....	4	13255	Clip, Mounting
8.....	4	13305	O-ring, -119
9.....	1	15150	Meter Cap Assy, Ext
		15237	Meter Cap Assy, Ext
10.....	1	13821	Body, Meter, 5600

For Service Assembly Numbers, See the Back of this Manual

1" Meter Assembly

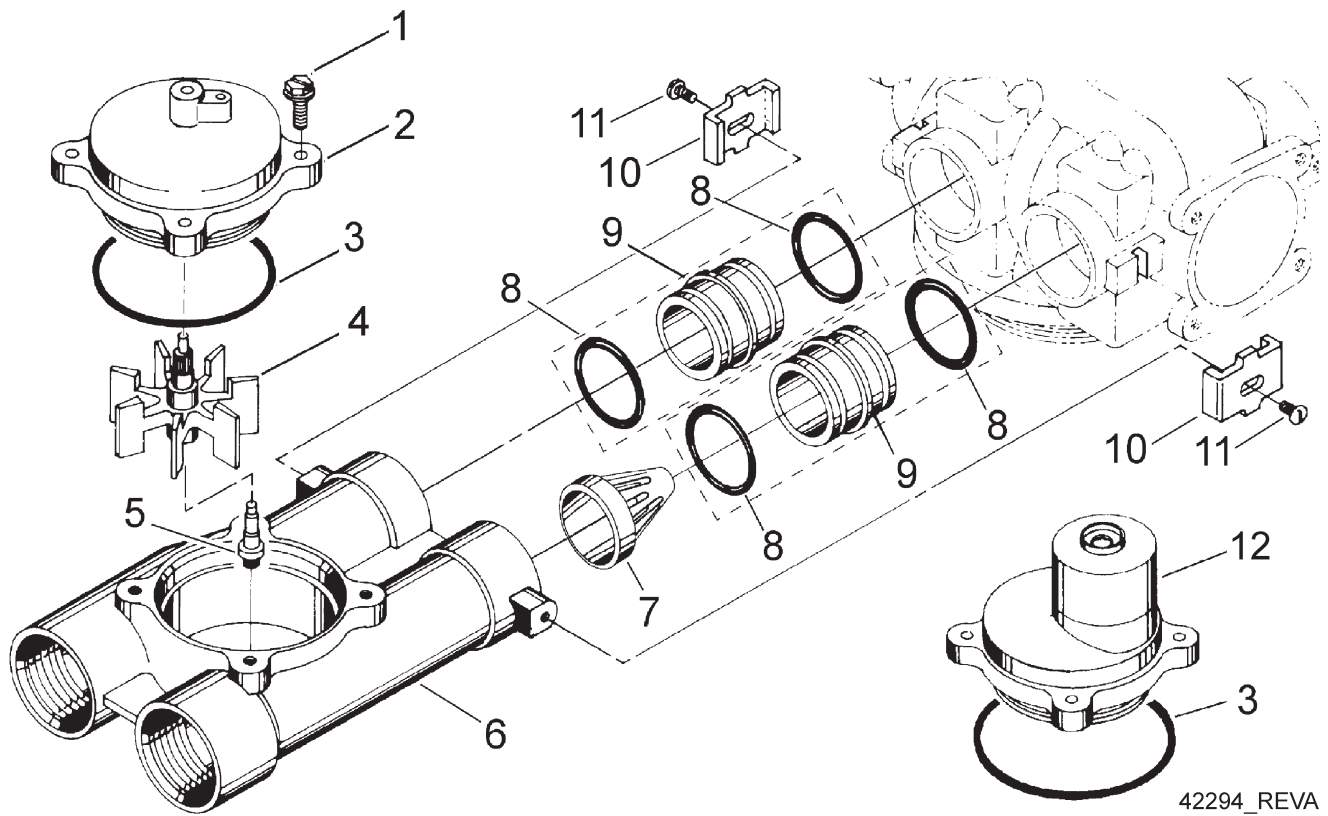

42294_REVA

Item No.	Quantity	Part No.	Description
1.....	4.....	12112.....	Screw, Hex Hd Mach 10-24 x 1/2
2.....	1.....	15218.....	Meter Cap Assy
		15237.....	Meter Cap Assy, EXT
3.....	1.....	13847.....	O-Ring, -137, STD/560CD, Meter
4.....	1.....	13509.....	Impeller, Meter
		13509-01.....	Impeller, Celcon
5.....	1.....	13882.....	Post, Meter Impeller
6.....	1.....	15043.....	Body, Meter, 9000 1"
7.....	1.....	14960.....	Flow Straightener, 1"
8.....	4.....	13305.....	O-Ring, -119
9.....	2.....	15078.....	Adapter, 1" Coupling
10.....	2.....	13255.....	Clip, Mounting
11.....	2.....	14202-01.....	Screw, Hex Wsh Mach, 8-32 x 5/16
12.....	1.....	15150.....	Meter Cap Assy, Ext
		15237.....	Meter Cap Assy, Ext

For Service Assembly Numbers, See the Back of this Manual

1 1/2" Meter Assembly

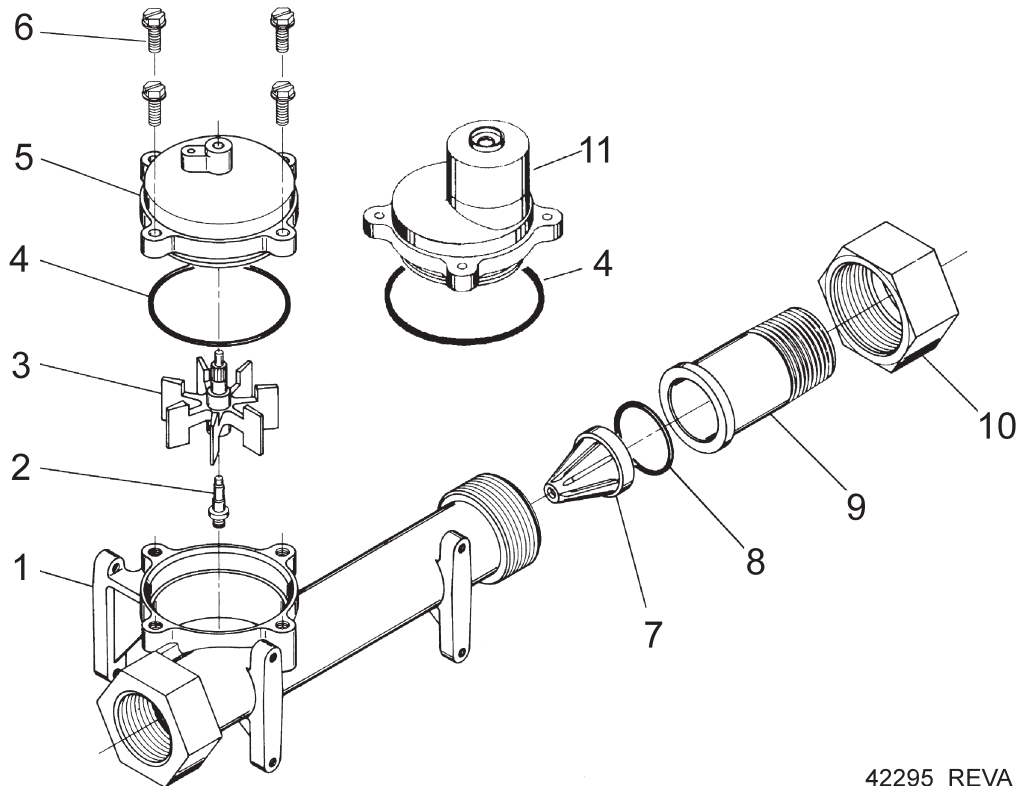

42295_REVA

Item No.	Quantity	Part No.	Description
1	1	17569	Body, Meter, 2850/9500
2	1	13882	Post, Meter Impeller
3	1	13509	Impeller, Meter
4	1	13847	O-Ring, -137, Std/560CD, Meter
5	1	15218	Meter Cap Assy
6	4	12112	Screw, Hex Hd Mach, 10-24 x 1/2 18-8 S.S.
7	1	17542	Flow Straightener, 1 1/2"
8	1	12733	O-Ring, -132
9	1	17544	Fitting, 1 1/2" Quick Connector
10	1	17543	Nut, 1 1/2", Q/C
11	1	15150	Meter Cap Assy, Ext
		15237	Meter Cap Assy, Ext
Not Shown ...	1	17790	Sleeve, Meter, 1 1/2" x 1"

For Service Assembly Numbers, See the Back of this Manual

9000/9100 Bypass Valve Assembly

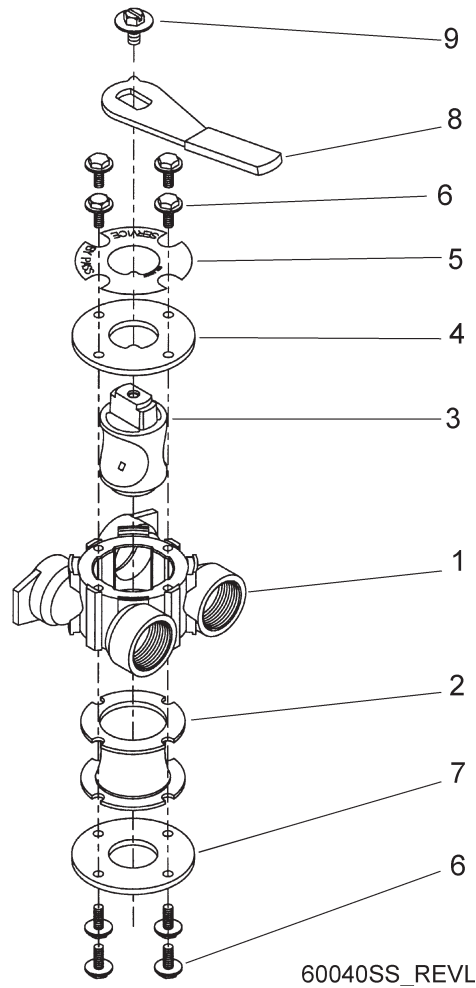

Item No.	Quantity	Part No.	Description
1.....	1	17290	By-Pass Body, 3/4"
		17290NP	By-Pass Body, 3/4" NP, 5600
		13399	By-Pass Body, 1"
		13399NP	By-Pass Body, 1" NP
2.....	1	14105	Seal, By-Pass, 560CD
3.....	1	11972	Plug, By-Pass, w/Wax
4.....	1	11978	Plate, By-Pass, Top
5.....	1	13604-01	Label, By-Pass, Standard Mount
6.....	8	15727	Screw, Hex Wsh Hd, 10-24 x 1/2
7.....	1	11986	Plate, By-Pass, Bottom
8.....	1	11979	Lever, By-Pass
9.....	1	11989	Screw, Sltd Ident, 1/4 - 14 x 1 1/2

For Service Assembly Numbers, See the Back of this Manual

Bypass Valve Assembly

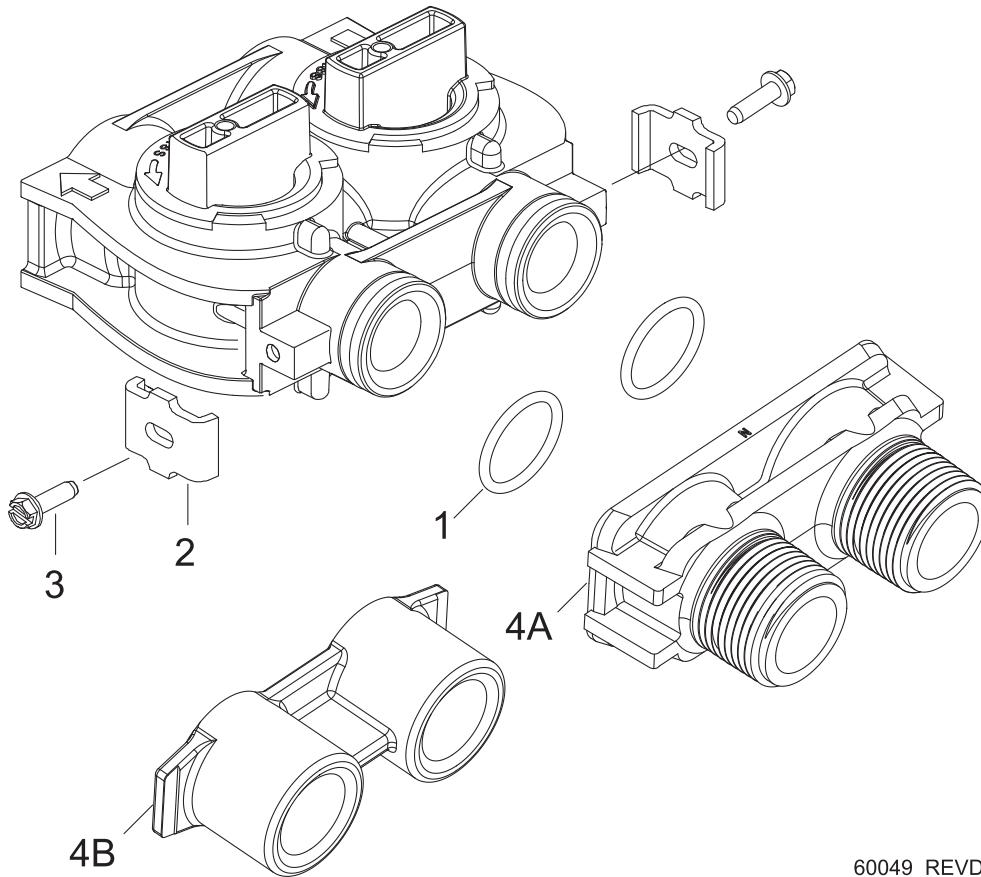

60049_REVD

Item No.	Quantity	Part No.	Description
1.....	2	13305	O-ring, -119
2.....	2	13255	Clip, Mounting
3.....	2	13314	Screw, Slot Ind Hex, 8-18 x .60
4A	1	18706	Yoke, 1", NPT, Plastic
		18706-02	Yoke, 3/4", NPT, Plastic
4B	1	41027-01	Yoke, 3/4", NPT, Cast, Machd
		41026-01	Yoke, 1", NPT, Cast, Machd, SS

For Service Assembly Numbers, See the Back of this Manual

1710 Brine Valve System (for 9500)

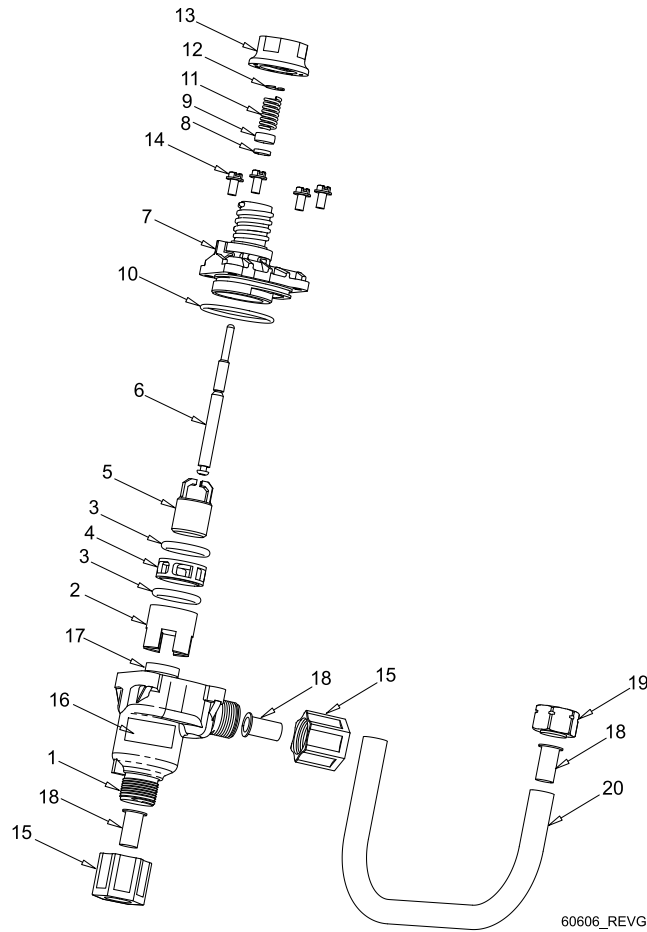

Item No.	Quantity	Part No.	Description
1.....	1.....	41202.....	Brine Valve, 1700, Plastic, Top
2.....	1.....	14785-01.....	Retainer, Flow Control
3.....	2.....	14811.....	O-ring, -210, 560CD, Brine
4.....	1.....	14798.....	Spacer, 1700, Brine
5.....	1.....	14795.....	Piston, Brine Valve
6.....	1.....	41429.....	Stem, Brine, 1710, Plastic, 9500
7.....	1.....	41201.....	Brine Valve, 1700, Plastic, Bottm
8.....	1.....	12550.....	Ring, Quad, -009
9.....	1.....	17908.....	Sleeve, Brine Valve Stem
10.....	1.....	41547.....	O-ring, 2mm x 35mm
11.....	1.....	15310.....	Spring, Brine Valve
12.....	1.....	10250.....	Ring, Retaining
13.....	1.....	17906-01.....	Guide, Brine Valve Stem
14.....	4.....	14202-01.....	Screw, Hex Wsh, Mach, 8-32 x 5/16"
15.....	2.....	41056.....	Nut Assy, 1/2" Plastic
16.....	1.....	41493-XX.....	Label, BLFC, 1710 (Specify GPM)
17.....	1.....		Washer, Flow (Specify GPM)
18.....	3.....	15415.....	Fitting, Insert, 1/2", Tube
19.....	1.....	15414.....	Nut, 2900, w/Sleeve
20.....	1.....	16959.....	Tube, Brine 9500/1700, 10.6"

For Service Assembly Numbers, See the Back of this Manual

2300 Safety Brine Valve

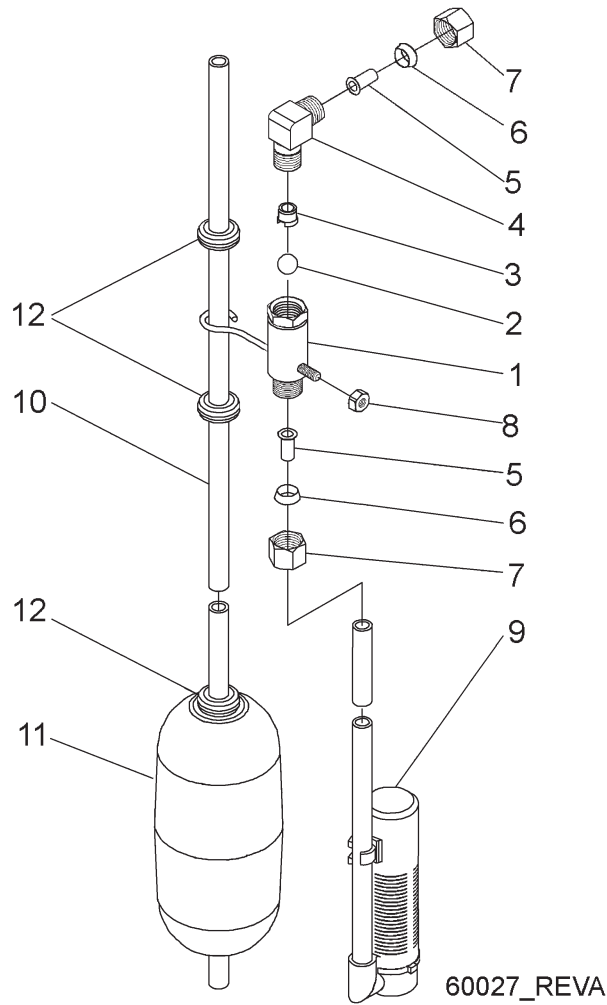

Item No.	Quantity	Part No.	Description
1.....	1.....	60027-00.....	Safety Brine Valve, 2300, Less Elbow
2.....	1.....	10138.....	Ball, 3/8", Brass
3.....	1.....	11566.....	Ball Stop, Slow Fill
4.....	1.....	10328.....	Fitting, Elbow, 90 Deg. 1/4 NPT x 3/8T
5.....	1.....	10332.....	Fitting, Insert, 3/8
6.....	1.....	10330.....	Fitting, Sleeve, 3/8 Celcon
7.....	1.....	10329.....	Fitting, Tube, 3/8 Nut, Brass
8.....	1.....	10186.....	Nut, Hex, 10-32
9.....	1.....	60002.....	Air Check, #500
10.....	1.....	10149.....	Rod, Float
11.....	1.....	10700.....	Float Assy, Blue/White
12.....	3.....	10150.....	Grommet, .30 Dia

For Service Assembly Numbers, See the Back of this Manual

2310 Safety Brine Valve

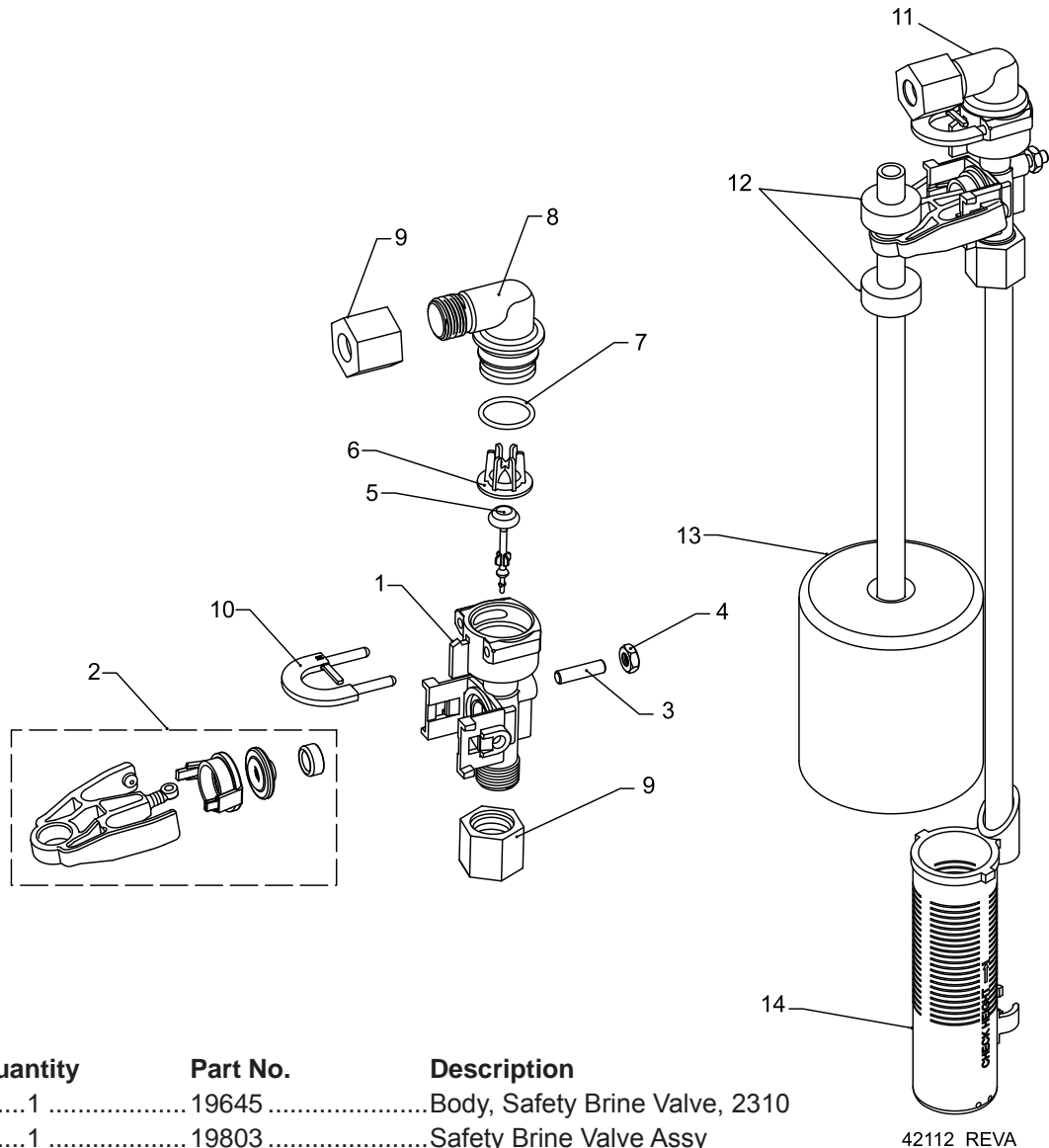

Item No.	Quantity	Part No.	Description
1.....	1	19645	Body, Safety Brine Valve, 2310
2.....	1	19803	Safety Brine Valve Assy
3.....	1	19804	Screw, Sckt Hd, Set, 10-24 x .75
4.....	1	19805	Nut, Hex, 10-24, Nylon Black
5.....	1	19652-01	Poppet Assy, SBV w/O-Ring
6.....	1	19649	Flow Dispenser
7.....	1	11183	O-Ring, -.017
8.....	1	19647	Elbow, Safety Brine Valve
9.....	2	19625	Nut Assy, 3/8" Plastic
10.....	1	18312	Retainer, Drain
11.....	1	60014	Safety Brine Valve Assy, 2310
12.....	2	10150	Grommet, .30 Dia
13.....	1	60068	Float Assy, 2310, w/30" Rod
14.....	1	60002	Air Check, #500

For Service Assembly Numbers, See the Back of this Manual

2350 Safety Brine Valve

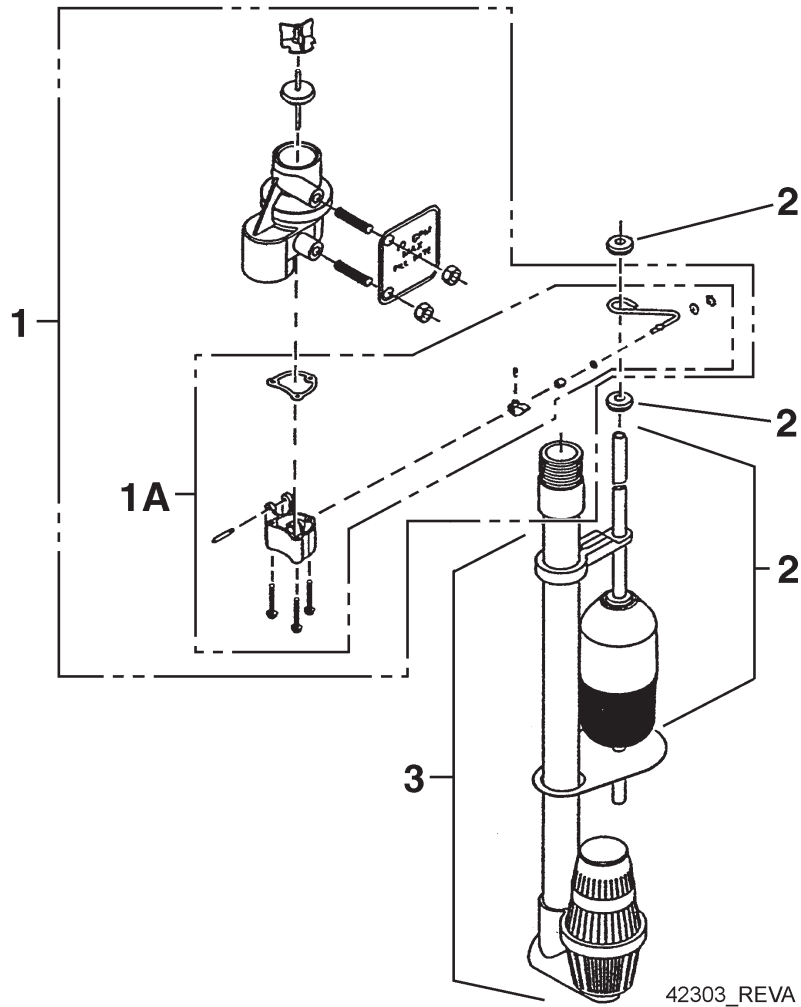

Item No.	Quantity	Part No.	Description
1.....	1	60038	Safety Brine Valve, 2350
1A	1	61024	Actuator Assy, 2350 Brine
2.....	1	60026-30.....	Float Assy, 400A/2350, 30" Red/Wht
3.....	1	60009-00.....	Air Check, #900, Commercial Less Fittings
		60009-01.....	Air Check, #900, Commercial, HW Less Fittings
Not Shown:			
	1	18603	Fitting Assy, 900 Air Check 2350

For Service Assembly Numbers, See the Back of this Manual

Troubleshooting

Problem	Cause	Correction
1. Water conditioner fails to regenerate.	A. Electrical service to unit has been interrupted	A. Assure permanent electrical service (check fuse, plug, pull chain, or switch)
	B. Timer is defective.	B. Replace timer.
	C. Power failure.	C. Reset time of day.
2. Hard water.	A. By-pass valve is open.	A. Close by-pass valve.
	B. No salt is in brine tank.	B. Add salt to brine tank and maintain salt level above water level.
	C. Injector screen plugged.	C. Clean injector screen.
	D. Insufficient water flowing into brine tank.	D. Check brine tank fill time and clean brine line flow control if plugged.
	E. Hot water tank hardness.	E. Repeated flushings of the hot water tank is required.
	F. Leak at distributor tube.	F. Make sure distributor tube is not cracked. Check O-ring and tube pilot.
	G. Internal valve leak.	G. Replace seals and spacers and/or piston.
3. Unit used too much salt.	A. Improper salt setting.	A. Check salt usage and salt setting.
	B. Excessive water in brine tank.	B. See problem 7.
4. Loss of water pressure.	A. Iron buildup in line to water conditioner.	A. Clean line to water conditioner.
	B. Iron buildup in water conditioner.	B. Clean control and add mineral cleaner to mineral bed. Increase frequency of regeneration.
	C. Inlet of control plugged due to foreign material broken loose from pipes by recent work done on plumbing system.	C. Remove piston and clean control.
5. Loss of mineral through drain line.	A. Air in water system.	A. Assure that well system has proper air eliminator control. Check for dry well condition.
	B. Improperly sized drain line flow control.	B. Check for proper drain rate.
6. Iron in conditioned water.	A. Fouled mineral bed.	A. Check backwash, brine draw, and brine tank fill. Increase frequency of regeneration. Increase backwash time.
7. Excessive water in brine tank.	A. Plugged drain line flow control.	A. Clean flow control.
	B. Plugged injector system.	B. Clean injector and screen.
	C. Timer not cycling.	C. Replace timer.
	D. Foreign material in brine valve.	D. Replace brine valve seat and clean valve.
	E. Foreign material in brine line flow control.	E. Clean brine line flow control.

Problem	Cause	Correction
8. Softener fails to draw brine.	A. Drain line flow control is plugged.	A. Clean drain line flow control.
	B. Injector is plugged.	B. Clean injector
	C. Injector screen plugged.	C. Clean screen.
	D. Line pressure is too low.	D. Increase line pressure to 20 P.S.I.
	E. Internal control leak	E. Change seals, spacers, and piston assembly.
	F. Service adapter did not cycle.	F. Check drive motor and switches.
9. Control cycles continuously.	A. Misadjusted, broken, or shorted switch.	A. Determine if switch or timer is faulty and replace it, or replace complete power head.
10. Drain flows continuously.	A. Valve is not programming correctly.	A. Check timer program and positioning of control. Replace power head assembly if not positioning properly.
	B. Foreign material in control.	B. Remove power head assembly and inspect bore. Remove foreign material and check control in various regeneration positions.
	C. Internal control leak.	C. Replace seals and piston assembly.

General Service Hints For Meter Control

Problem: Softener delivers hard water

Reason: Reserve capacity has been exceeded.

Correction: Check salt dosage requirements and reset program wheel to provide additional reserve.

Reason: Program wheel is not rotating with meter output.

Correction: Pull cable out of meter cover and rotate manually. Program wheel must move without binding and clutch must give positive clicks when program wheel strikes regeneration stop. If it does not, replace timer.

Reason: Meter is not measuring flow.

Correction: Check meter with meter checker.

9000/9100/9500 Meter Flow Data

9000 Meter Flow Data

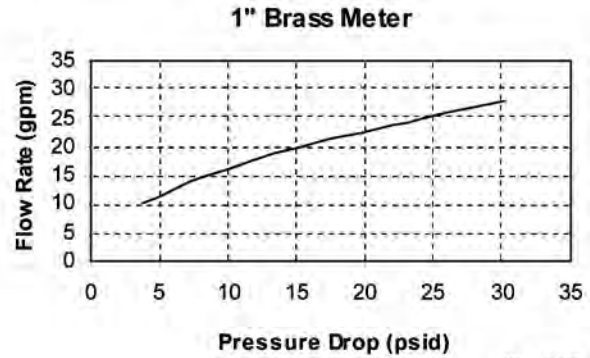
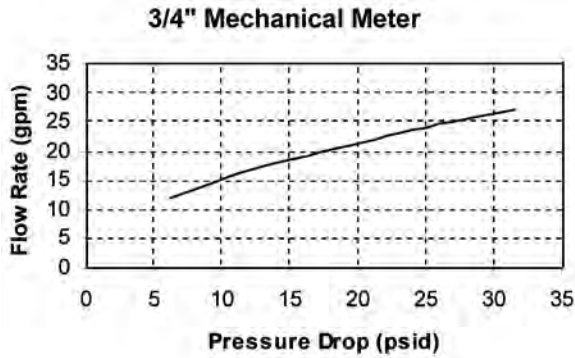

TR: 18467
41092

9100 Meter Flow Data

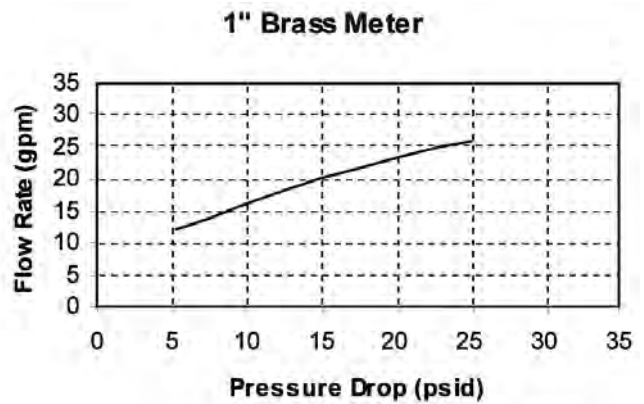
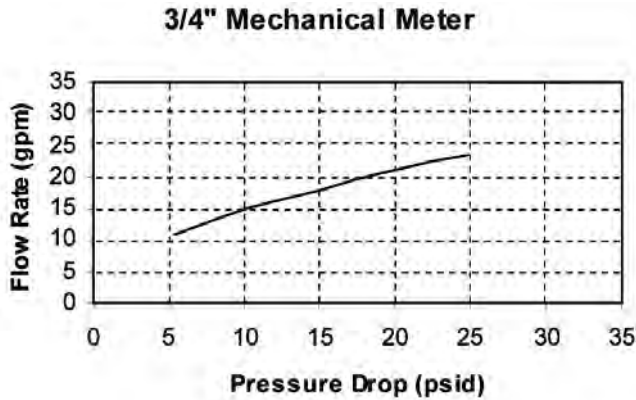

TR: 18467
41092

9500 Meter Flow Data

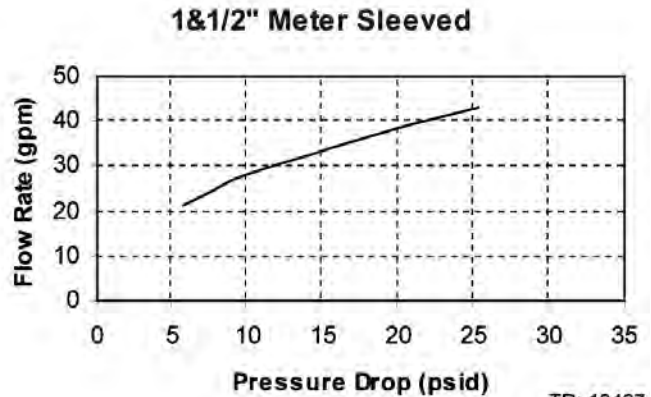
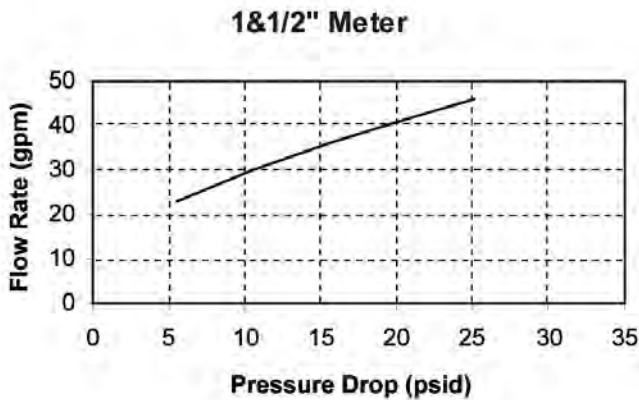

TR: 18467
41092

9000/9100 Injector Flow Data (1600 Series Injectors)

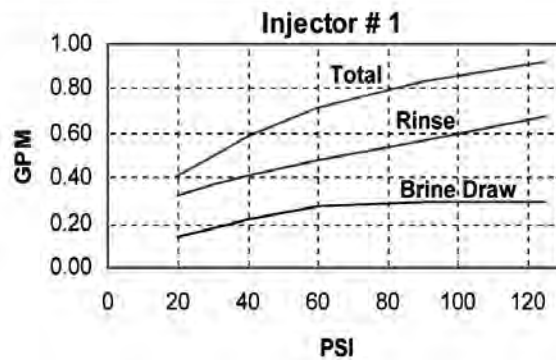
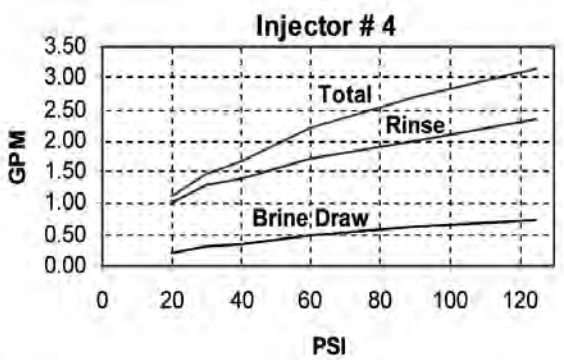
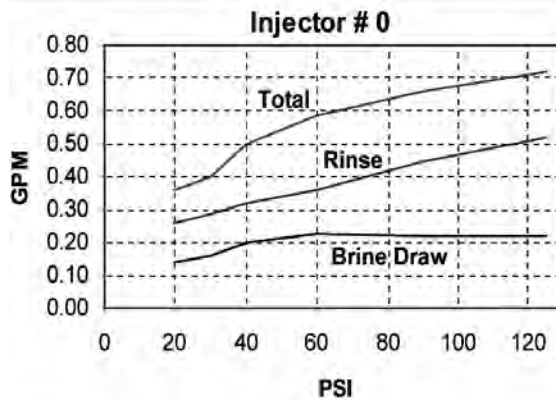
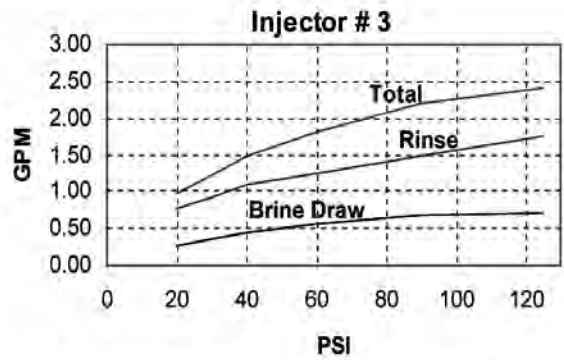
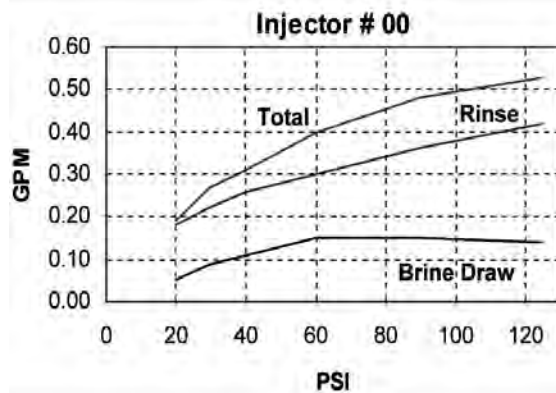
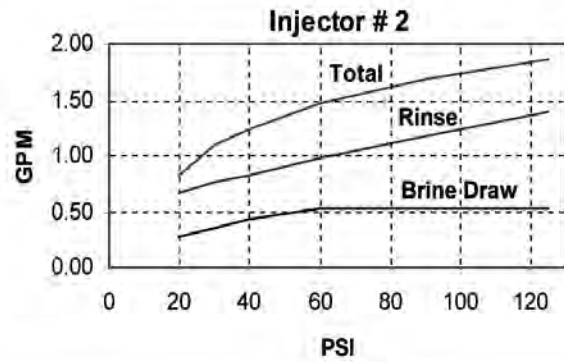
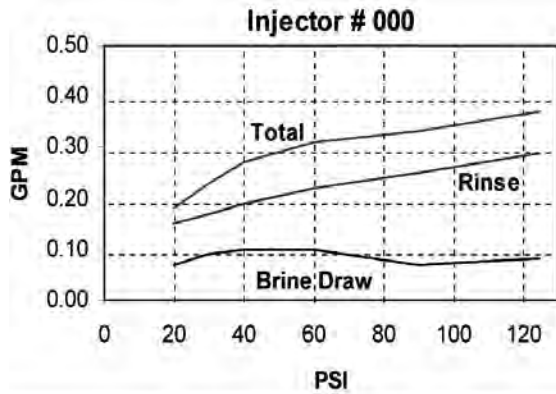

TR: 18467
41092

9500 Injector Flow Data (1600 & 1700 Series Injectors)

1600 Series Injectors

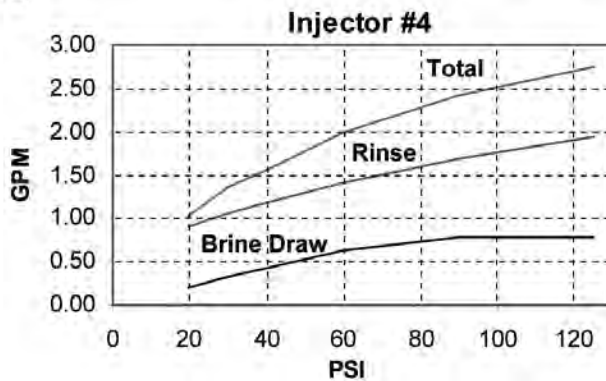
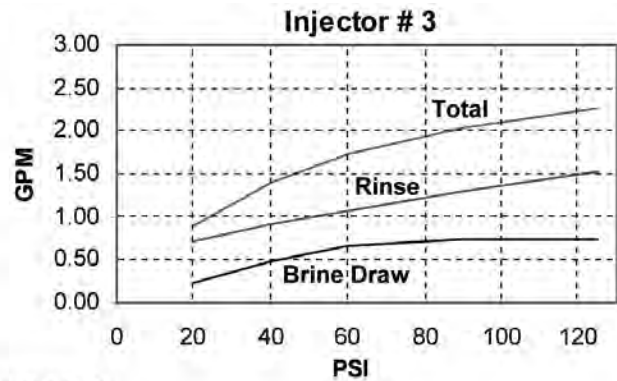
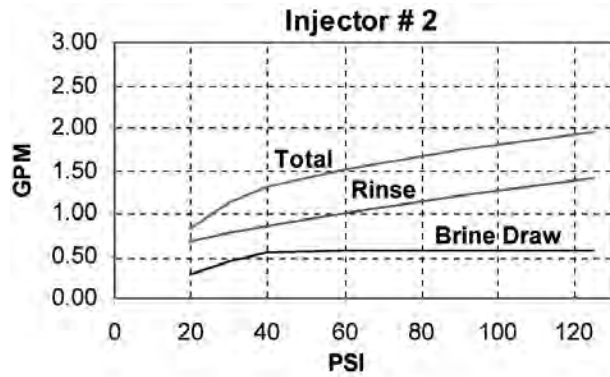

TR: 18467
41092

1700 Series Injectors

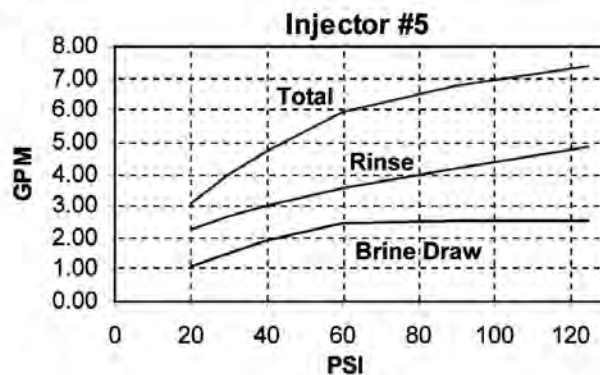
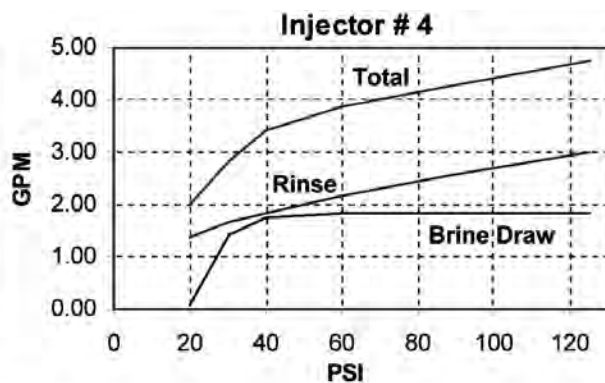
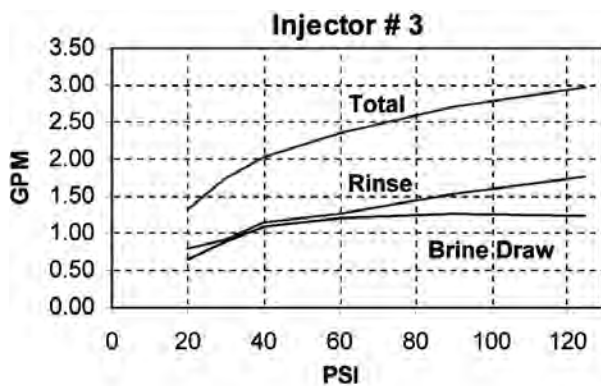

TR: 18467
41092

9000 Control Dimensions

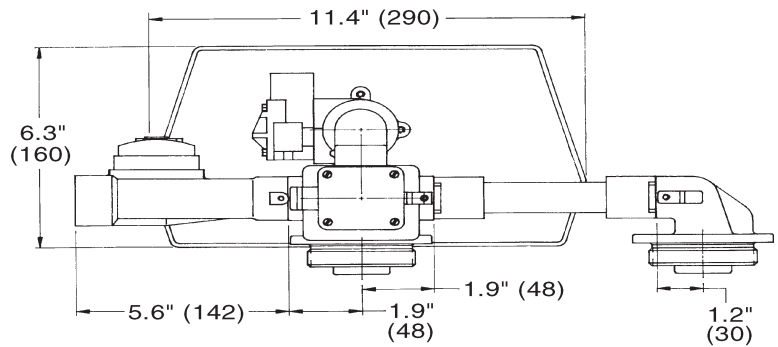
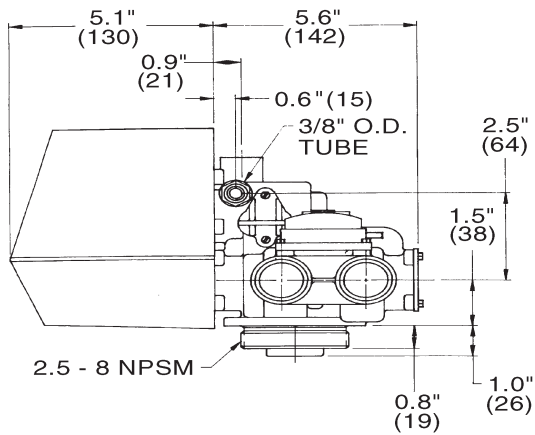
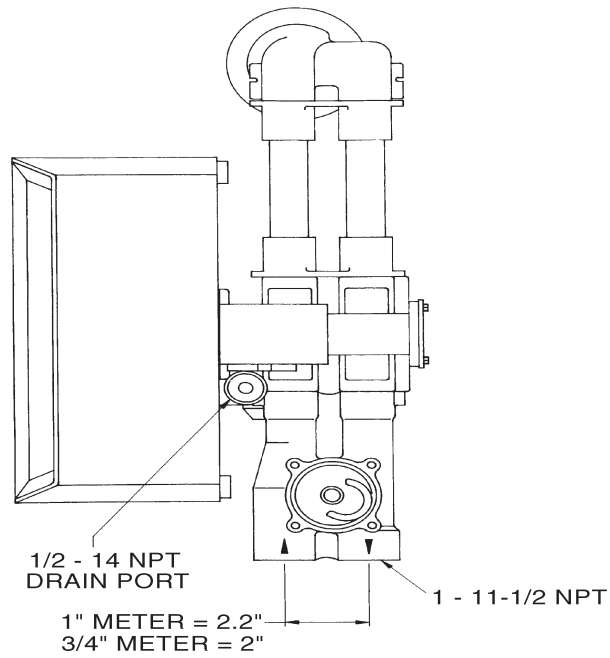

61500-9000LNE_REVA

9100 Control Dimensions

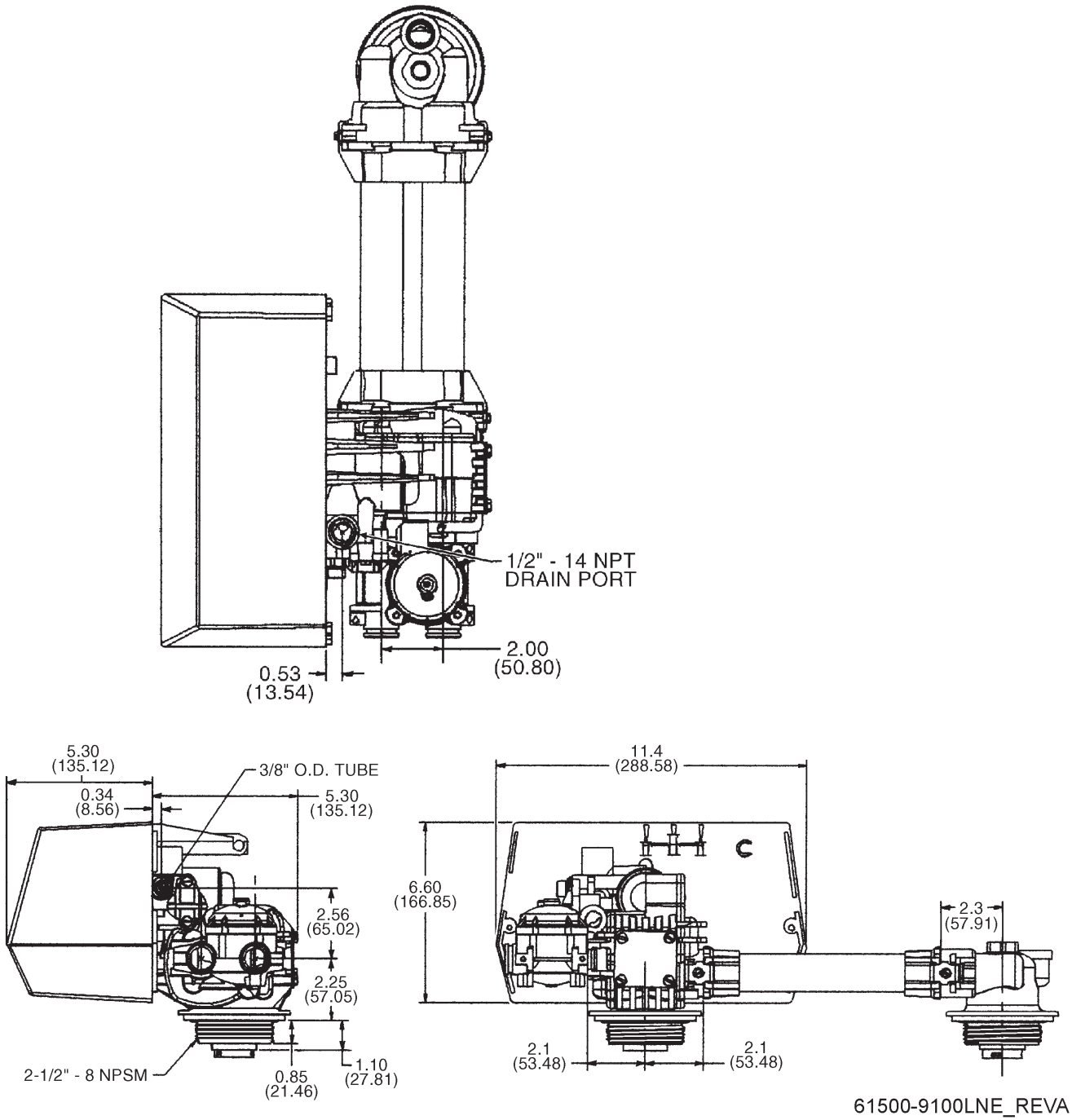

9500 Control Dimensions

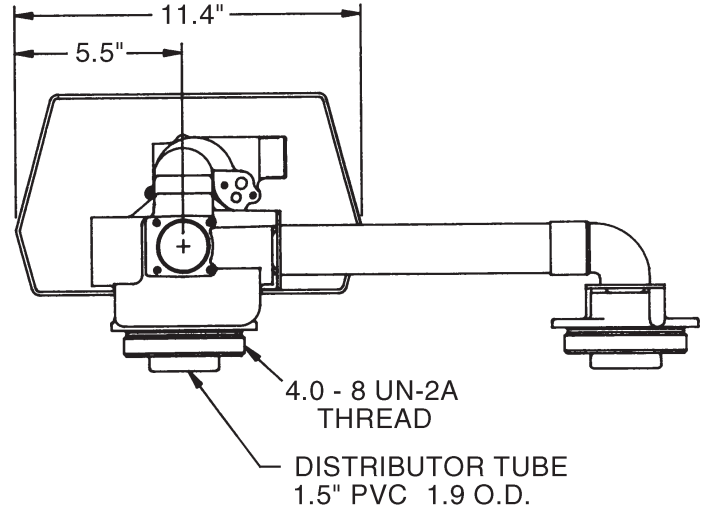
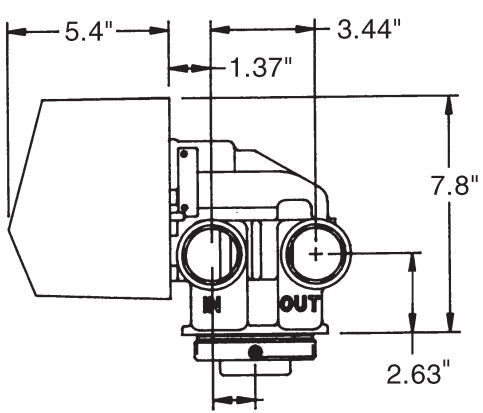
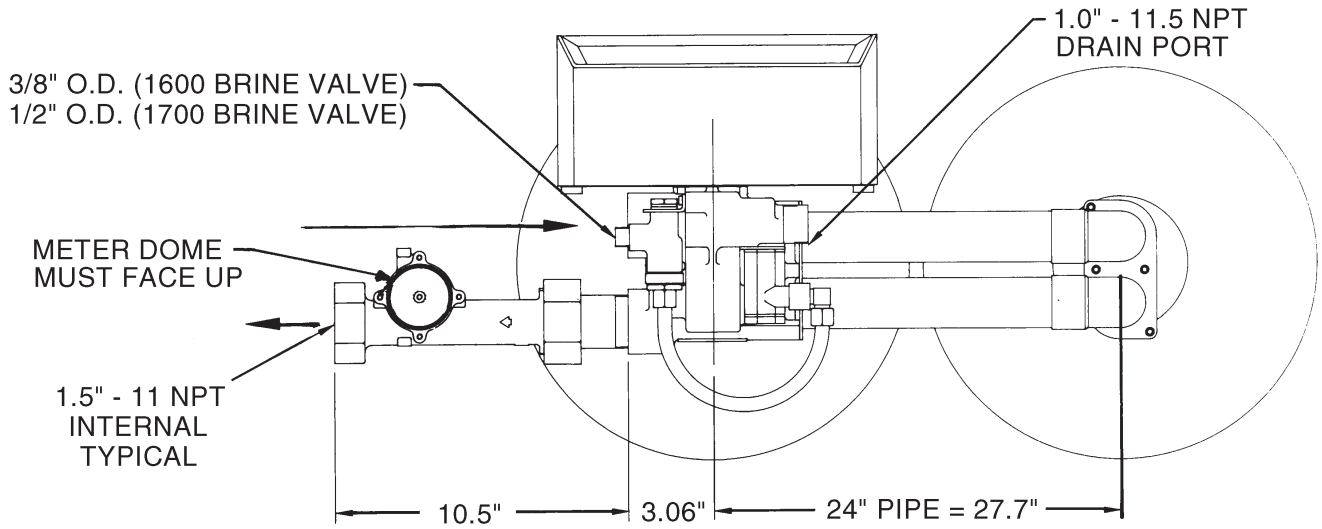

61500-9500LNE_REVA

Water Conditioner Flow Diagrams

In Service Position

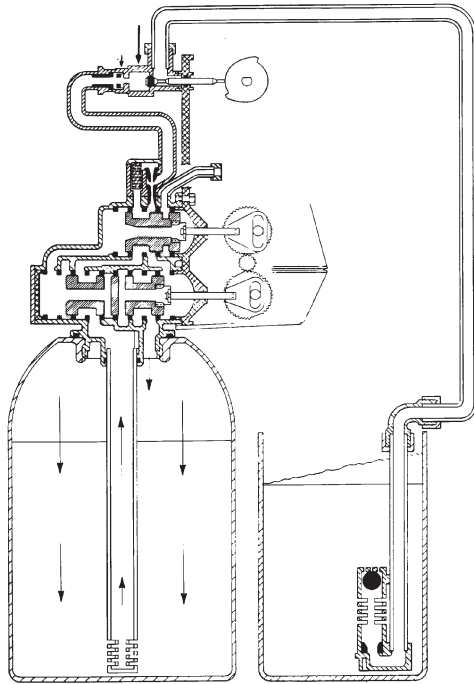

**Tanks Switching Position
(Meter Initiated Regeneration)**

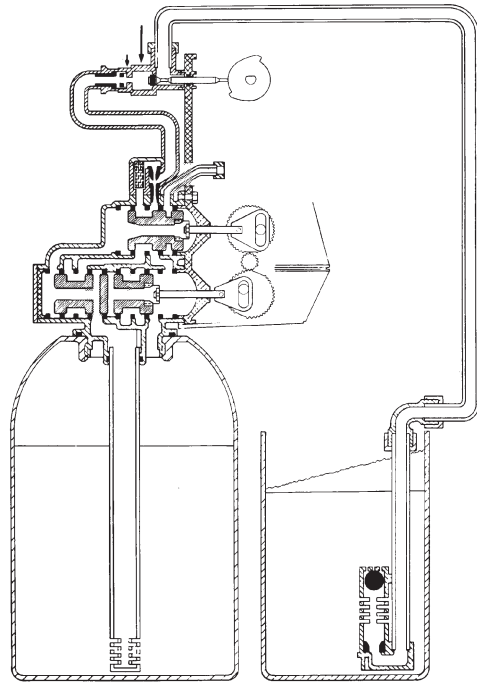

Backwash Position

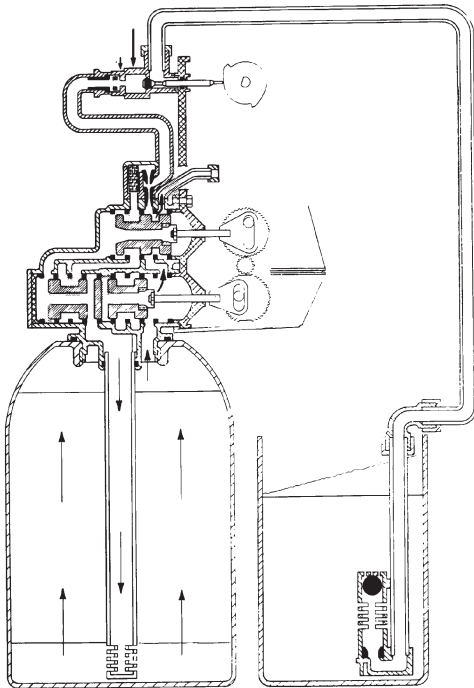

Brine Draw Position

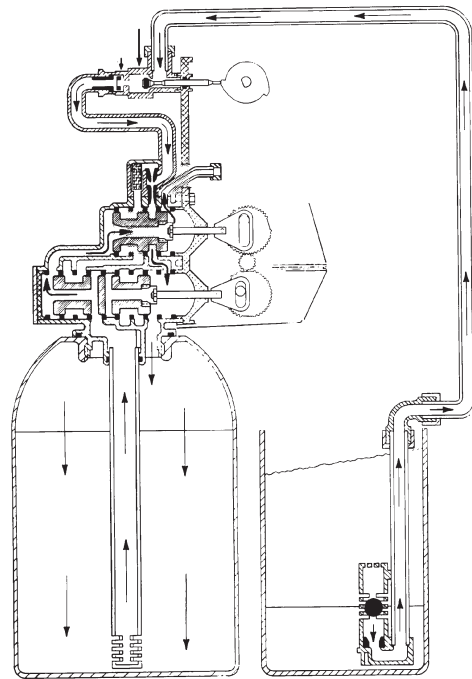

Water Conditioner Flow Diagrams

Slow Rinse Position

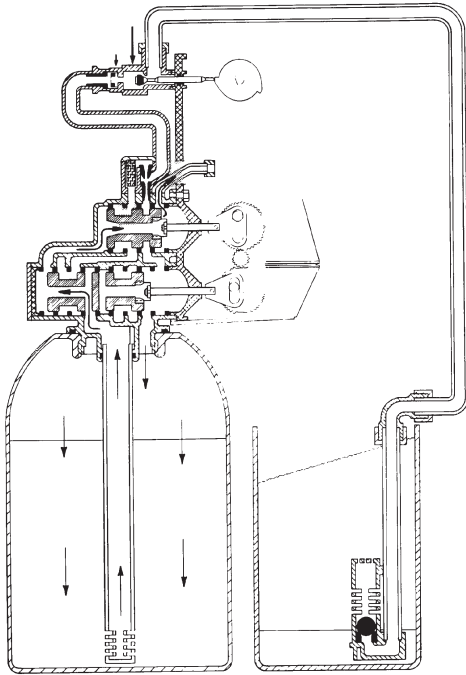

Rapid Rinse Position

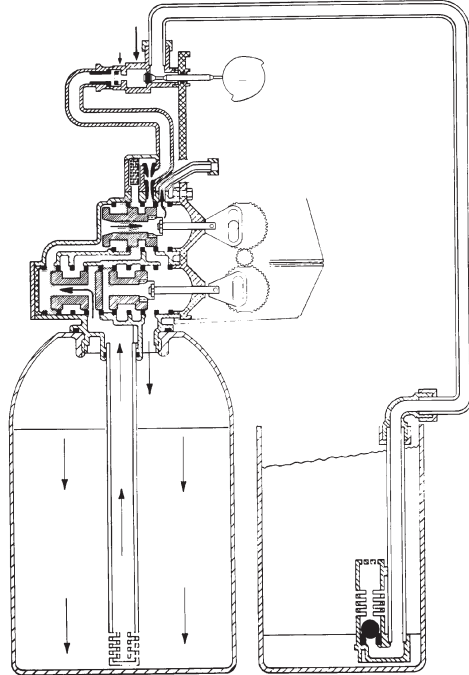

Brine Tank Fill Position

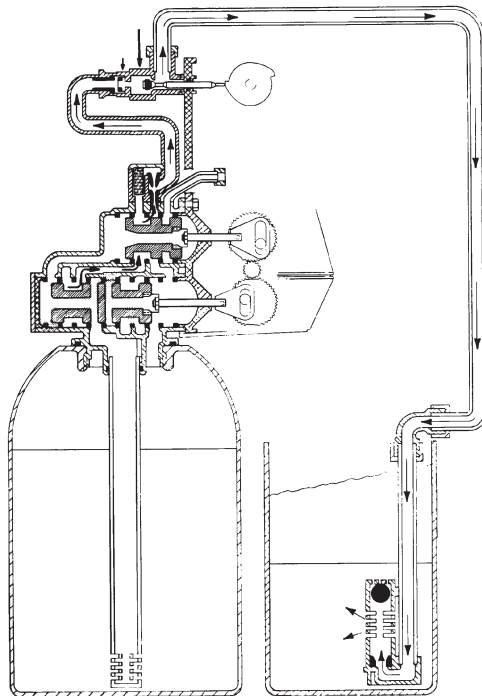

In Service Position, Tanks Switched

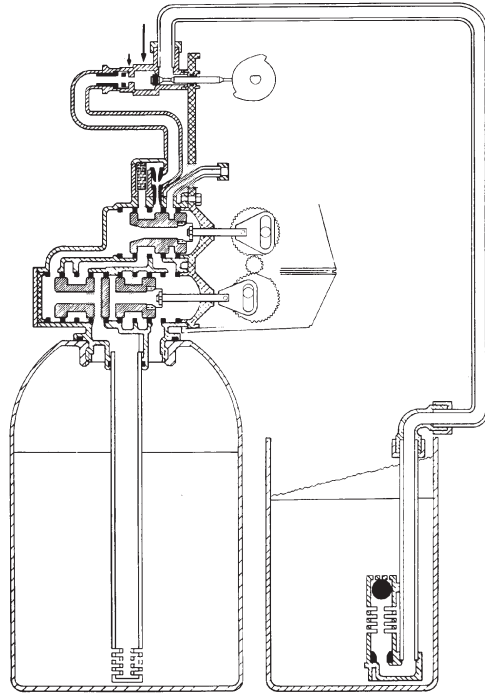

9000/9500 Wiring Diagram

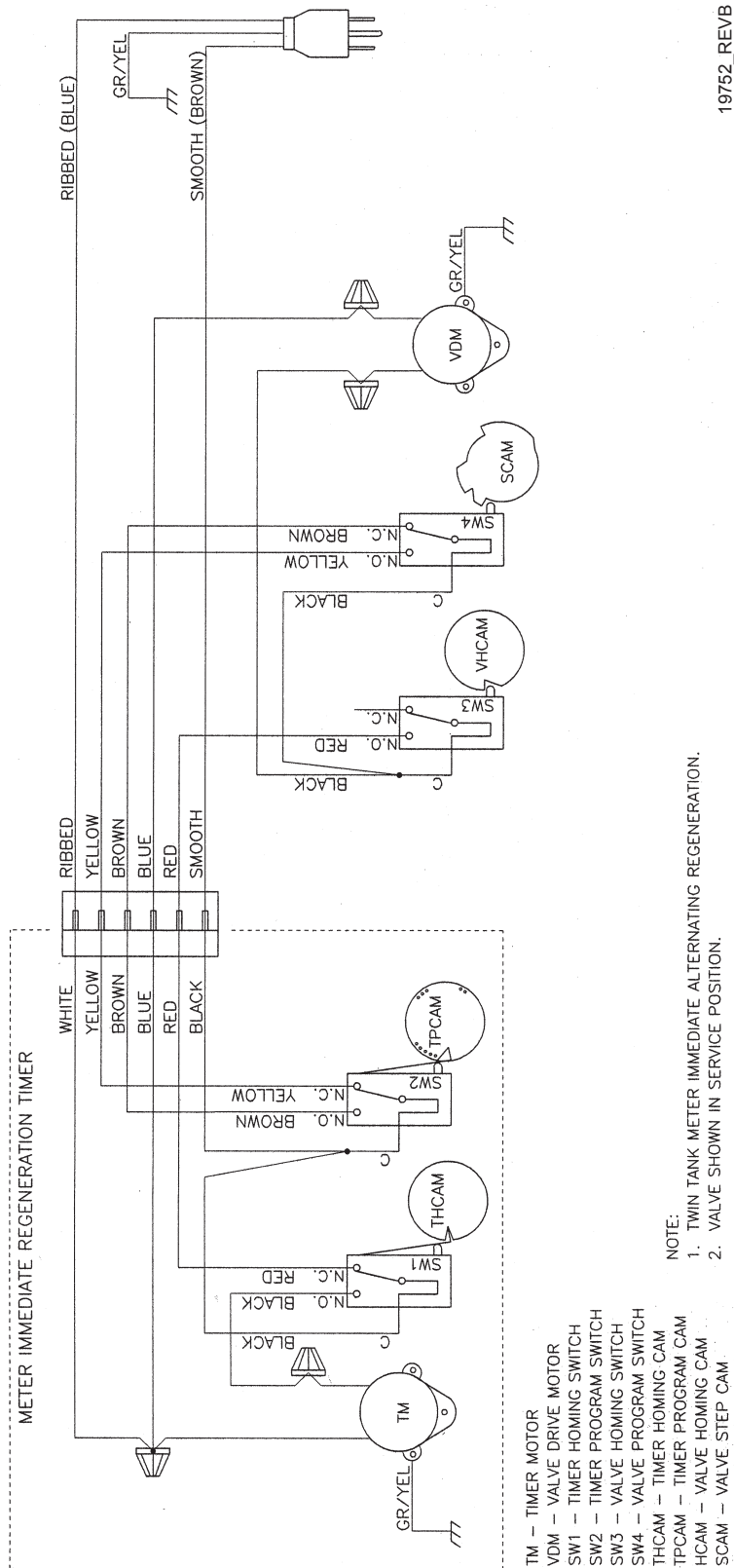

19752_REV B

Service Assemblies

Brine Line Flow Controls (9000/9100):

60022-12	BLFC, .125 GPM, 5000/5600/9000/9100
60022-25	BLFC, .25 GPM, 5000/5600/9000/9100
60022-50	BLFC, .50 GPM, 5000/5600/9000/9100
60022-100	BLFC, 1.0 GPM, 5000/5600/9000/9100
60350	Brine Valve Assy, 9000/9100

Brine Line Flow Controls (9500):

60020-25	BLFC, .25 GPM, 1600
60020-50	BLFC, .50 GPM, 1600
60020-100	BLFC, 1.0 GPM, 1600

Brine Valve Assemblies:

60037-610	Brine Valve, 9500/1600, .25 GPM, Cold & HW 180°
60037-620	Brine Valve, 9500/1600, .50 GPM, Cold & HW 180°
60037-630	Brine Valve, 9500/1600, 1.0 GPM, Cold & HW 180°
60350	Brine Valve Assy 9000/9100, Cold & HW 180°
60350-01	Brine Valve Assy, 9000/9100/Twinfl100, Cold & HW 180°

1700 Brine Valve Assemblies (9500):

60039-XX	Brine Valve, 1700/9500, Cold & HW 180°
----------	-------	--

Bypass Assemblies:

60040SS	Bypass Valve, 5600, 3/4" NPT
60041SS	Bypass Valve, 5600, 1" NPT
60049	Bypass Plastic Assy

Injector Assemblies (9000/9100):

60385-X	Injector Assembly (specify size of injector)
---------	-------	--

Injector	Number	DLFC	Number	BLFC	Number
Red #0 00	Blank 0	Blank 0
White #1 01	1.2 1	0.25 1
Blue #2 02	1.5 2	0.50 2
Yellow #3 03	2.0 3	1.00 3
Green #4 04	2.4 4		
		3.0 5		
		3.5 6		
		4.0 7		
		5.0 8		
		7.0 9		

Injector Assemblies (9500):

60381-03	Injector Assy, 1700, #3, Cold & HW 150°
60381-04	Injector Assy, 1700, #4, Cold & HW 150°
60381-05	Injector Assy, 1700, #5, Cold & HW 150°
60381-06	Injector Assy, 1700, #6, Cold & HW 150°
60480-01	Injector Assy, 1600, #1, Plastic, Cold Water
60480-02	Injector Assy, 1600, #2, Plastic, Cold Water
60480-03	Injector Assy, 1600, #3, Plastic, Cold Water
60480-04	Injector Assy, 1600, #4, Plastic, Cold Water
60481-21	Injector Assy, 1600, #1, SS, HW 180°
60481-21	Injector Assy, 1600, #2, SS, HW 180°
60481-21	Injector Assy, 1600, #3, SS, HW 180°
60481-21	Injector Assy, 1600, #4, SS, HW 180°

Meter Assemblies (9000/9100):

15078-01	Adapter, 1" Coupling
60086	Meter Assy, 5600/9000/9100, 3/4" Std/Range
60087	Meter Assy, 5600/9000/9100, 3/4", Ext
60389	Meter Assy, 9000/9100, 1"
60389NP	Meter Assy, 9000/9100, 1", N/P
60389-20	Meter Assy, 9000/9100, 1", BSP/Metric
60390	Meter Assy, 9000/9100, 1", Ext
60390NP	Meter Assy, 9000/9100, 1", Ext, N/P
60390-20	Meter Assy, 9000/9100, 1", Ext/BSP/Metric
60612	Meter Assy, 9000/9100, 1", Std Range, HW 150°
60612NP	Meter Assy, 9000/9100, 1", Std Range, HW 150°, NP
14038	Meter Cap Assy
15150	Meter Cap Assy, Ext
15218	Meter Cap Assy
15218NP	Meter Cap Assy, Std, NP
15237	Meter Cap Assy, Ext
15237NP	Meter Cap Assy, Ext, NP
13509	Impeller, Meter
13509-01	Impeller, Celcon, HW 150°

Meter Assemblies (9500):

60610-01	Meter, 2850/9500, 1 1/2" Std
60610-01HW	Meter, 2850/9500, 1 1/2" Std, HW 150°
60610-01NP	Meter, 2850/9500, 1 - 1/2" Std, N/P
60610-02	Meter, 2850/9500, 1 - 1/2" Ext
60610-02HW	Meter, 2850/9500, 1 1/2" Ext, HW 150°
60610-02NP	Meter, 2850/9500, 1 - 1/2" Ext, N/P
60610-21	Meter, 2850/9500, 1 - 1/2" Std/BSP Metric
60610-21NP	Meter, 2850/9500, 1 - 1/2" Std/BSP Metric, Nickel Plated
60610-22	Meter, 2850/9500, 1 - 1/2" Ext/BSP Metric
60610-22NP	Meter, 2850/9500, 1 - 1/2" Ext/BSP Metric/Nickel Plated
60611-01HW	Meter, 2850/9500, 1" Sleeve, 1 1/2" Std, HW 150°
60611-01	Meter, 2850/9500, 1" Sleeve, 1 1/2" Std Meter
60611-01NP	Meter, 2850/9500, 1" Sleeve, NP 1 1/2" Std Meter
60611-02	Meter, 2850/9500, 1" Sleeve, 1 1/2" Ext Meter
60611-02NP	Meter, 2850/9500, 1" Sleeve, NP 1 1/2" Ext Meter
17790	Sleeve, Meter, 1 1/2" x 1" (NOTE: when reducing a 1-1/2" meter to a 1" meter, the program wheel and timer settings must be changed to a 1" meter size)

Service Assemblies

Meter Checker Kits:

60460 Meter Checker Kit, Std
60461 Meter Checket Kit, Ext

Piston Assemblies:

60108 Piston Assy, 9500, Upper
60108-01 Piston Assy, 9500, Upper, HW 180°
60109 Piston Assy, 9500, Lower
60109-01 Piston Assy, 9500, Lower HW, 180°
60400 Piston Assy, 9000/9100, Top
60400-01 Piston Assy, 9000/9100, HW Upper, 180°
60401 Piston Assy, 9000/9100, Lower
60401-01 Piston Assy, 9000/9100 Lower, HW 180°

Seal & Spacer Kits:

60125 Seal & Spacer Kit, 5600/9000 Top
60125-20 Seal & Spacer Kit, Top, 559 PE
Cold and Chloramine
60125HW Seal & Spacer Kit, 9000/9100,
Upper HW 180°
60133 Seal & Spacer Kit, 9500, Lower,
Cold & HW 180°
60133-20 Seal & Spacer Kit, 9500, Lower
60133-30 Seal & Spacer Kit, 9500, Lower
60134 Seal & Spacer Kit, 9500, Upper,
Cold & HW 180°
60134-20 Seal & Spacer Kit, 9500, Upper
60134-30 Seal & Spacer Kit, 9500, Upper
60421 Seal & Spacer Kit, 9000/9100, Bottom
60421-20 Seal & Spacer Kit, 9000/9100,
Bottom 559PE
60421HW Seal & Spacer Kit, 9000/9100,
Bottom, HW 180°

Second Tank Assemblies (9000):

14202-01 Screw, Hex Wsh Mach, 8-32 x 5/16
18-8 S.S.
13255 Clip, Mounting
15078-01 Adapter Assy, 1" Coupling
14864-01 Adapter, 9000/9100, 2nd Tank,
Machd w/O-rings
14864-01NP Adapter, 9000/9100, 2nd Tank, Machd, NP
15823-06 Yoke Assy, 6" Tank & 6" Tube
15823-06NP Yoke Assy, 6" Tank, NP 6" Tubes
15823-12 Yoke Assy, 6" - 12" Tank, 8 1/2 Tube
15823-12NP Yoke Assy, 6" - 12" Tank, NP 8 1/2" Tubes
15823-14 Yoke Assy, 14" Tank, 10 1/2" Tube
15823-14NP Yoke Assy, 14" Tank, NP 10 1/2" Tube
15823-16 Yoke Assy, 16" Tank, 12 1/2" Tube
15823-16NP Yoke Assy, 16" Tank, NP 12 1/2" Tube

Second Tank Assemblies (9100):

60425-12 Tube Assy, 9100, 6-12" Tanks
60425-16 Tube Assy, 9100, 13-16" Tanks
14865 Adapter Assy, 2nd Tank, 9100
61419 Kit, 1.05" Distributor Adapter

Second Tank Assemblies (9500):

16919-01 Valve Body, 9500 Machd
16919-01NP Valve Body, 9500 Machd, NP
16919-21 Valve Body, 9500 BSP, Mtrc, Machd
16919-21NP Valve Body, 9500 BSP, Mtrc, Machd
Nickel Plated
60715-16 Tube Assy, 9500, 2nd Tank for
14" to 16" Tanks
60715-16NP Tube Assy, 9500, 2nd Tank, NP for
14" to 16" Tanks
60715-20 Tube Assy, 9500, 2nd Tank for 20" Tanks
60715-24 Tube Assy, 9500, 2nd Tank for 20" and
24" Tanks
60715-24NP Tube Assy, 9500, 2nd Tank, Nickel
for 20-24" Tanks

Tools:

12763 Stuffer Tool Assy, 5600/9000
13061 Puller Assy, Port Ring
13759 Tool, DLFC Retainer

Valve Body Assembly (9100):

40688 Valve Body Assy, 9100
18303 O-ring, -336
18569 Retainer, Tank Seal

Notes
