

# DIAPHRAGM PUMPS

# BOOSTER PUMPS | RECIRCULATING PUMPS

## 6800/8800 SERIES



Aquatec's original product, and still the "global standard" in booster pump technology, providing reliable inlet pressure for efficient membrane utilization. These pumps are capable of continuous duty and are effective for recirculation based applications as well. They are ideally suited to work with hydro-pneumatic storage systems but are compatible with most hydraulic shut-off valves also.

These pumps are commonly used with one or more of our flow control components including: pressure switches (PSW Series), tank level controllers (TLC Series) or electronic shut-off valves (ESO Series).

A typical "R.O. Kit" includes a booster pump, pressure switch, and a transformer. All system components are sold separately.

### TYPICAL APPLICATIONS

- Water Treatment/RO(\*)
- Carbonation Systems
- Misting Systems
- Alternative Energy/Solar
- Medical Labwater
- Laser Cooling Systems
- Fuel Cells

(\*) See sample data sheet at right for model number 6840-2J03-B221, our most popular Reverse Osmosis booster pump

FULL RANGE CAPABILITIES FOR 6800/8800 MODELS ARE .4LPM TO 2.5 LPM, 200PSI MAXIMUM.

DISCHARGE PRESSURE (PSI)	PUMPHEAD MODEL				RECOMMENDED BY-PASS PRESSURE	
	68X0		68X1		PSI	CODE
	FLOW (LPM)	CURRENT (AMPS)	FLOW (LPM)	CURRENT (AMPS)		
80	0.38	0.62	0.45	0.72	110	J
70	0.41	0.58	0.50	0.67	100	I
60	0.43	0.53	0.58	0.61	90	H
50	0.49	0.49	0.61	0.56	80	G
40	0.55	0.43	0.63	0.49	70	F
30	0.59	0.38	0.66	0.43	60	E
20	0.63	0.33	0.70	0.36	50	D
10	0.67	0.27	0.77	0.28	40	B
OPEN	0.73	0.23	0.84	0.23	30	A

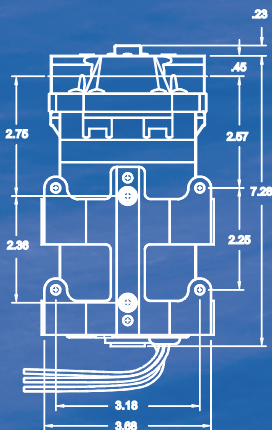
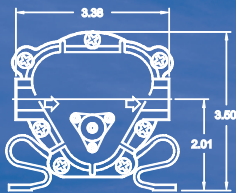

### COMPLETING THE PART NUMBER:

- 68XX-2X03-B221
- Flexible Mounting Plate (Other Types Available)
  - See Performance Data for Recommended By-pass Pressure and Code
  - By-Pass Pressure Relief Control Valve
  - Select Pumphead Model From Performance Data Chart
  - 2 = Open Ports for 1/4" Compression Fitting
  - 4 = Push to Connect Ports for 1/4" Tubing
  - 5 = Push-to-Connect Ports for 3/8" Tubing

### TECHNICAL SPECIFICATIONS:

- POWER:** Safe operation with low energy (24 watts), low voltage (12-24V) motors. Can be used with compatible transformers (100VAC, 120VAC, 230VAC), to be ordered separately.
- ENVELOPE DIMENSIONS:** Approximately 3"x 4"x 7", 6 lbs.
- MOUNTING:** Our patented "flex-mount" baseplate significantly dampens vibration and reduces noise. Other steel mounting baseplates and "universal" baseplates are available at no additional cost. Pump performance may be affected by location and positioning.
- CONTROL OPTIONS:** Internal Bypass (20-200 psi)
- FITTINGS:** Available options include built-in 3/8", 1/4", or 5/16" John Guest half cartridges

### PRIMING CAPABILITIES:

	68X0	68X1
PRIME (FEET)	7	8

# Series 8800 Pump

Model: 88XX-2X03-B424

Flow Range: Open Flow = 1.90-2.60 LPM

At 80 PSI = 1.00-1.40 LPM

## COMPLETING THE PART NUMBER:

88XX-2X03-B424

- Steel Mounting Plate (Other Types Available)
- See Performance Data for Recommended By-pass Pressure and Code
- By-Pass Pressure Relief Control Valve
- Select Pumphead Model From Performance Data Chart
- 3 = Open Ports for 3/8" Compression Fitting
- 4 = Push to Connect Ports for 1/4" Tubing
- 5 = Push-to-Connect Ports for 3/8" Tubing

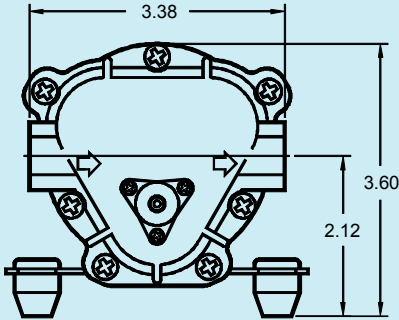

## SPECIFICATIONS:

### ■ MOTOR:

TYPE:

24 VAC, Permanent Magnet, Totally Enclosed, Non-Ventilated

LEADS:

20 AWG, 6" LONG

TEMP. LIMITS:

This Motor is Not Equipped with Thermal Protection. For User Safety, Optimal Performance, and Maximum Motor Life, The Motor Surface Temperature Should Not Exceed 150°F (66°C), as Shown on the Heat Rise Graph.

DUTY CYCLE:

See Heat Rise Graph

### ■ PUMP DESIGN:

3 Chamber Diaphragm Pump, Self Priming, Capable of Being Run Dry

### ■ TYPICAL APPLICATION:

Pre-Filter Water Treatment (R.O. Boost)

### ■ MATERIALS:

HOUSINGS:

Nylon

VALVES:

EPDM

DIAPHRAGM:

Santoprene

FASTENERS:

Stainless Steel

### ■ LIQUID TEMPERATURE:

170°F (77°C) Max.

### ■ PUMP CERTIFICATIONS:

NSF Standard 58

### ■ PRIMING CAPABILITIES:

	88X0	88X1	88X2
PRIME (FEET)	4	5	6

### ■ FITTINGS:

TYPE	SHAPE	KIT NO.	CONNECTS TO...
3/8" COMPRESSION	STRAIGHT	25-145	3/8" TUBING
3/8" COMPRESSION	ELBOW	25-146	3/8" TUBING
3/8" STEM	STRAIGHT	25-144	3/8" JOHN GUEST PUSH-ON FITTING

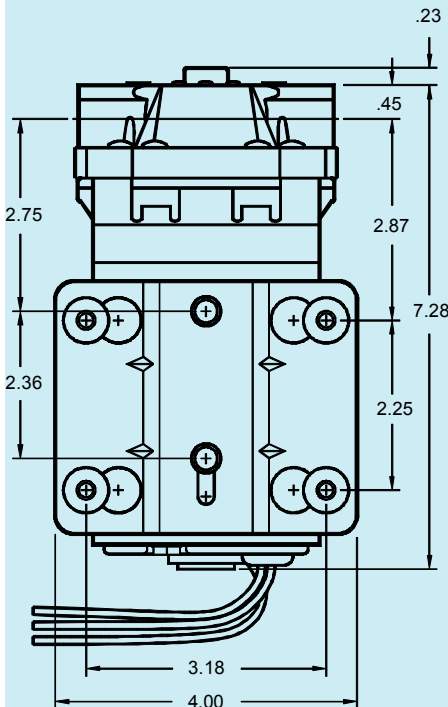

WEIGHT: 6 lbs.

Distributed By:

**APPLIED MEMBRANES INC.**<sup>®</sup>

Industry Leader in RO Expertise and Membrane Applications since 1983™

2450 Business Park Dr., Vista, CA 92081 ☎ (760) 727-3711 📠 (760) 727-4427

🌐 www.appliedmembranes.com ✉ sales@appliedmembranes.com

DOCUMENT:  
ISSUED:  
REVISED:

DS88XX-2X03-B424  
10/20/99  
5/4/00



# Series 8800 Pump

Model: 88XX-2X03-B424

PERFORMANCE DATA								
DISCHARGE PRESSURE (PSI)	PUMPHEAD MODEL						RECOMMENDED BY-PASS PRESSURE	
	88X0		88X1		88X2		PSI	CODE
	FLOW (LPM)	CURRENT (AMPS)	FLOW (LPM)	CURRENT (AMPS)	FLOW (LPM)	CURRENT (AMPS)		
80	1.00	1.20	1.20	1.40	1.40	1.65	110	J
70	1.10	1.14	1.30	1.29	1.50	1.55	100	I
60	1.20	1.06	1.40	1.19	1.60	1.43	90	H
50	1.30	0.98	1.50	1.10	1.80	1.29	80	G
40	1.40	0.90	1.55	0.99	1.90	1.17	70	F
30	1.50	0.82	1.70	0.89	2.00	1.02	60	E
20	1.55	0.72	1.85	0.77	2.20	0.91	50	D
10	1.80	0.60	2.00	0.64	2.50	0.75	40	B
OPEN	1.90	0.53	2.10	0.58	2.60	0.70	30	A

PERFORMANCE MEASURED WITH FLOODED INLET (0 PSI), 70°F (21°C) AMBIENT AND WATER TEMPERATURE, AND VOLTAGE CONTROLLED AT 24 VAC. POSITIVE INLET PRESSURE WILL INCREASE THE DISCHARGE PRESSURE BY A SIMILAR AMOUNT, FOR A GIVEN FLOW. MAXIMUM INLET PRESSURE IS 60 PSI.

SHADED AREA DENOTES CONTINUOUS OPERATION CAPABILITY AT DESIGNATED PRESSURE AND CURRENT.

## HEAT RISE

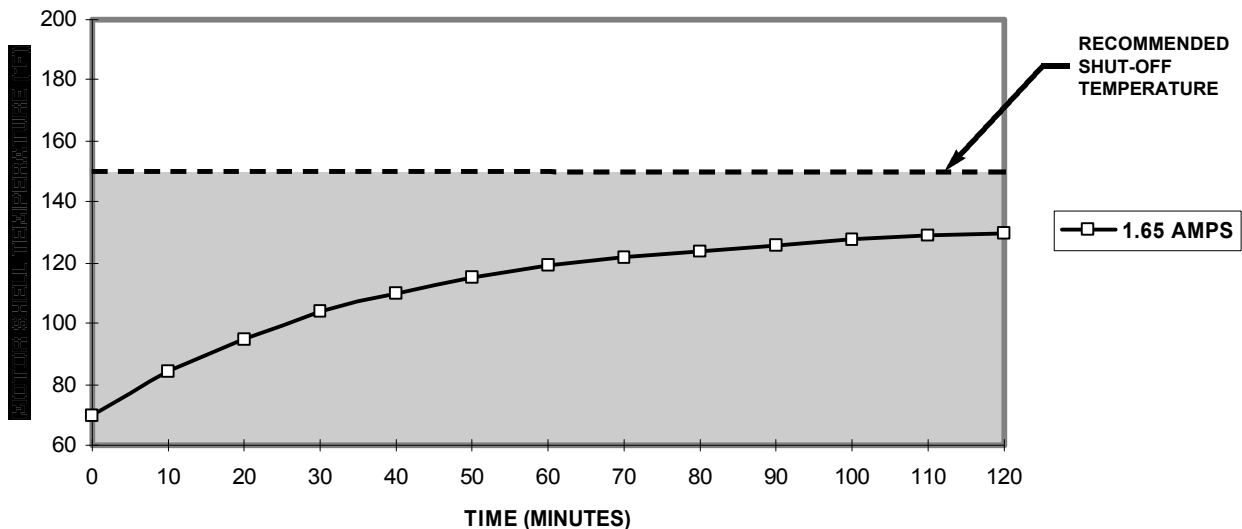

All of the pump models in the Performance Data and Heat Rise charts are in the shaded area, meaning they are capable of sustaining continual running, at any of the above listed pressures, without shutting down to allow the motor to cool. To conserve wearing parts, however, the pump should only operate as needed.

Care should be exercised in selecting the proper transformer for this 24 VAC motor. The largest “wall mount” transformer from Aquatec is only rated to .80 amps. Aquatec’s “table top” transformer is rated to 2.00 amps. By-Pass pressures must also be considered when selecting a suitable transformer, in the event the pump is allowed to reach the preset by-pass pressure for sustained periods.

ALL PERFORMANCE AND HEAT RISE FIGURES ARE APPROXIMATE. ACTUAL VALUES WILL VARY WITH AMBIENT CONDITIONS.

## TRANSFORMERS



Aquatec transformers are specifically designed to power the products in this catalog.

Nominal primary voltages/frequencies, line voltage variations, and system related feed or back pressures may influence your ultimate selection. Our transformers are both current and temperature protected for additional safety protection.

Aquatec pump-transformer combinations are designed to operate at maximum efficiency under a wide range of voltage conditions without overheating or overloading. This can save the end-user thousands of kilowatt hours per year compared to less efficient pumps.

Part No.	Input Voltage	Output Voltage Max. Current	Primary Input Cord Length	Secondary Output Cord Length	Overload Protection
TACS 104-48	100VAC, 50/60 Hz	24 VAC, 2 A	6 ft.	6 ft.	Thermal Fuse
TACS 114-48	115-120VAC, 60 Hz	24 VAC, 2 A	6 ft.	6 ft.	Thermal Fuse
TACS 234-48RF	230 VAC, 50 Hz	24 VAC, 2 A	6 ft.	6 ft.	Circuit Breaker, Auto-Reset
TAS 104-19*	100VAC, 50/60 Hz	24 VAC, 800 mA	None, Plug-In	6 ft.	Circuit Breaker, Auto-Reset
TAS 114-19EP	116-120 VAC, 50 Hz	24 VAC, 800 mA	None, Plug-In	6 ft.	Circuit Breaker, Auto-Reset
TAS 234-19EP	230 VAC, 50 Hz	24 VAC, 800 mA	None, Plug-In	6 ft.	Circuit Breaker, Auto-Reset

## REPLACEMENT KITS

Aquatec and its distributors can provide fully assembled replacement kits to allow you to further extend the life of our pump products. These kits are available in three different configurations: upper housing assembly, valve housing assembly and lower housing assembly

### 5-Chamber Pump

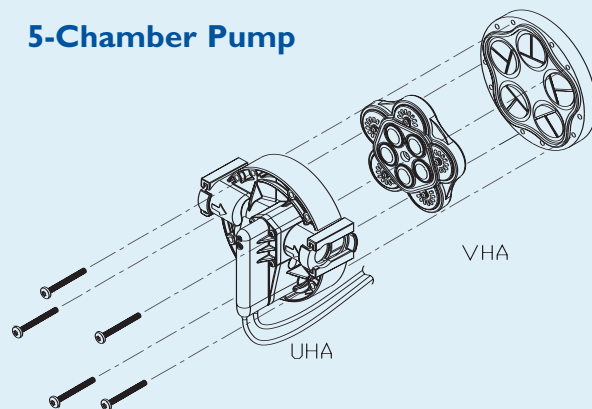

### 3-Chamber Pump

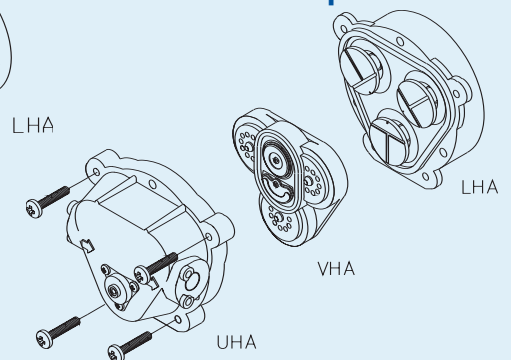

**UHA:** Upper Housing Assembly • **VHA:** Valve Housing Assembly • **LHA:** Lower Housing Assembly