

4 3 2 1

450
PSI

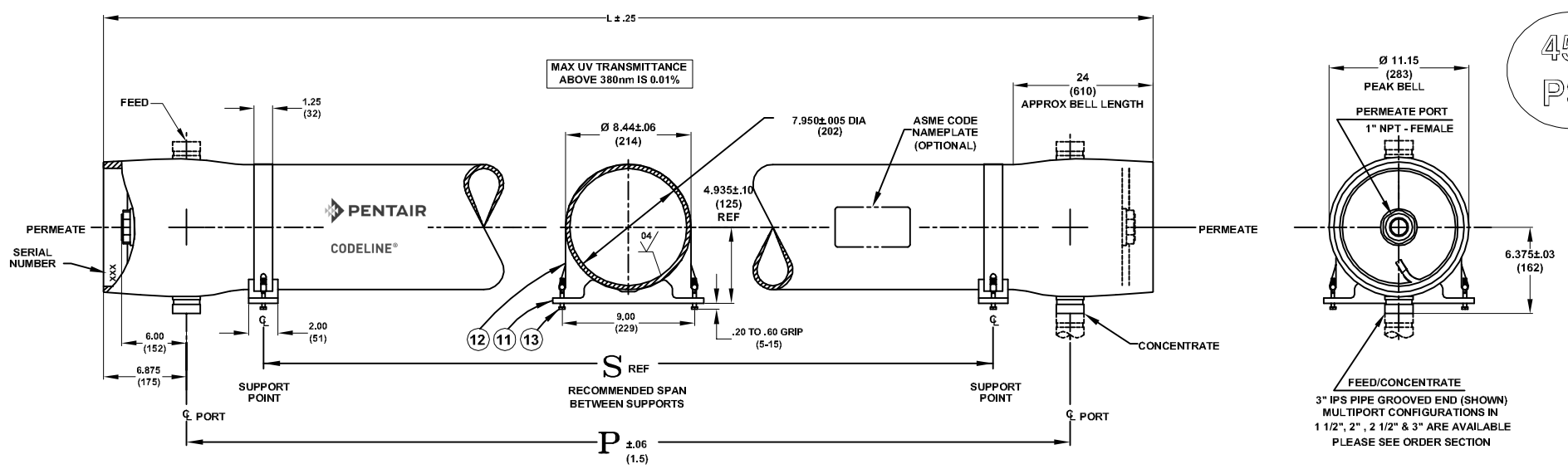

DWG REF	QTY	PART NUMBER	DESCRIPTION	MATERIAL
SHELL				
1	1	ORDER SECTION	SHELL	Filament Wound Epoxy/Glass composite - Head locking grooves integrally wound in place.
2	A/R		F/C Port	CF3M *
3	A/R		F/C Port Seal	Ethylene Propylene
HEAD				
4	2	96157	Bearing Plate	6061-T6 Aluminium alloy - Hard anodized *
5	2	96159	Sealing Plate	Engineering Thermoplastic.
6	2	96161	Permeate Port	Engineering Thermoplastic.
7	2	45066	Port Nut	Engineering Thermoplastic.
8	2	96000	Head Seal	Ethylene Propylene - O - Ring
9	2	45312	Perm Port Seal	Ethylene Propylene - O - Ring
HEAD INTERLOCK				
10	2	47336	Quick Release Spiral Ring	316 Stainless Steel.
VESSEL SUPPORT				
11	2*	52169	Saddle	Engineering Thermoplastic.
12	2*	45042	Strap Assy.	304 Stainless Steel-PVC Cushion.
13	4	46265	Strap screw.	5/16-18 UNC, 18-8 Stainless Steel.
ELEMENT INTERFACE				
14	2	A/R	Adapter	Engineering Thermoplastic.
15	2	52245	Adapter seal	Ethylene Propylene - O - Ring
16	4	A/R	PWT Seal	Ethylene Propylene - O - Ring
17	1	96163	Thrust Cone	Engineering Thermoplastic.

*3 each furnished with length code 4,5,6,7&8.

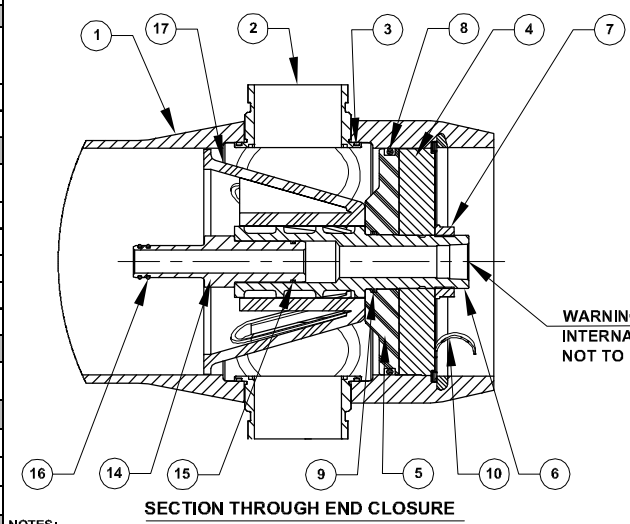

NOTES:-

- ♦ MAX. ANGULAR VARIATION BETWEEN ANY PORTS ±0.5°.
- ♦ DIMENSION IN INCHES (MM APPROX.)
- ♦ SHELL EXTERIOR COATED WITH WHITE, HIGH GLOSS POLYURETHANE PAINT.
- ♦ NOT TO BE USED FOR CONSTRUCTION UNLESS CERTIFIED.
- ♦ ITEM 17 DOWNSTREAM ONLY.
- ♦ GRADE CF3M PER ASME SA-351/316L AS PER SA-479.
- ♦ 450 PSI FOR METALLIC PERMPORTS.
- * FOR OPTIONAL PART NUMBERS, REFER PAGE 3.
- ** WEIGHTS GIVEN IN THE TABLE ARE FOR HIGHEST CONFIGURATION AND WILL VARY WITH CHANGE IN CONFIGURATION

WARNING ⚠
INTERNAL PORT PRESSURE NOT TO EXCEED 125 PSI #

CAUTION: INCORRECT MANIFOLDING WILL CAUSE SEVERE LOCAL STRESS AROUND PORT AND MAY RESULT IN LEAKS AND PREMATURE FAILURE; TAKE EVERY PRECAUTION LISTED ON REVERSE, SEE INSTALLATION INSTRUCTIONS FOR FURTHER DETAILS

PO NUMBER	
CUSTOMER NAME	
PROJECT NAME	
TOTAL QUANTITY	

PORT CONFIGURATION DETAILS	
PORT CONFIG	VESSEL QUANTITY

Dash Length	L IN(MM)	P IN(MM)	S IN(MM)	Approx Weight LB(KG)
-1	60.75 (1543)	47 (1194)	8X1 (222)	91 (41)
-2	100.75 (2559)	87 (2210)	48X1 (1238)	111 (50)
-3	140.75 (3575)	127 (3226)	80X1 (2032)	131 (59)
-4	180.75 (4591)	167 (4242)	64X2 (1626)	152 (69)
-5	220.75 (5607)	207 (5258)	78X2 (1981)	172 (78)
-6	260.75 (6623)	247 (6274)	92X2 (2337)	192 (87)
-7	300.75 (7639)	287 (7290)	106X2 (2692)	215 (98)
-8	340.75 (8655)	327 (8306)	120X2 (3048)	235 (107)

PENTAIR
CODELINE®

MODEL - 80H45
MEMBRANE HOUSING

DRAWN DATE	AND 03 JAN 08	ECN 3236	DWG. NO. 99167	REV. P	
CHECKED DATE	MD 03 JAN 08				
APPROVED DATE	SS 03 JAN 08	DATE 25APR14	SCALE NONE	SIZE A3	SHEET 1 OF 3

4 3 2 1

RATING:

DESIGN PRESSURE.....450 PSIG at 190°F
 (3.1 MPa at 88°C)
 MIN. OPERATING TEMP.....20°F
 (-7°C)
 FACTORY TEST PRESSURE.....675 PSIG/ 495 PSIG
 (4.65 MPa)/(3.41 MPa)
 QUALIFICATION PRESSURE2700 PSI
 (18.62 MPa)

INTENDED USE:

The CodeLine 80H45 Fiberglass RO Pressure Vessel is designed for continuous, long term use as housing for reverse osmosis membrane elements to desalt typical brackish waters at pressures up to 450 psi. Any make of eight-inch nominal diameter spiral-wound element is easily accommodated; the appropriate interfacing hardware for the element specified is furnished with the vessel.

The CodeLine 80H45 is designed in accordance with the engineering standards of the Boiler and Pressure Vessel Code of the American Society of Mechanical Engineers (ASME) Code. At small additional cost vessels can be inspected during construction by an ASME Authorized Inspector and ASME Code stamped.

The CodeLine 80H45 must be installed, operated and maintained in accordance with the listed precautions and good industrial practice to assure safe operation over a long service life.

The high performance Filament wound FRP shell must be allowed to expand under pressure; undue restraint at support points or piping connections can cause leaks to develop in the shell. This side-ported vessel requires special precautions in mounting and connection to piping so that the vessel will not be subjected to excessive stress due to bending moments acting at the side openings in the fiberglass shell. The end closure, incorporating close fitting, interlocking metal components, must be kept dry and free of corrosion; deterioration can lead to catastrophic mechanical failure of the head.

Pentair Water will assist the purchaser in determining the suitability of this standard vessel for their specific operating conditions. The final determination however, including evaluation of the standard material of construction for compatibility with the specific corrosive environment, shall be the responsibility of the purchaser. Alternate materials with enhanced corrosion resistance are available on special order.

Specifications are subject to change without notice.

PRECAUTIONS:

- DO...read, understand and follow all instructions; failure to take every precaution will void warranty and may result in vessel failure
- DO...mount the shell on horizontal members at span “S” using compliant vessel supports furnished; Shim saddles if required. Tighten hold down straps just snug
- DO...align and center side ports with the manifold header. Correct, causes of misalignment in a row of vessels connected to the same header
- DO...use flexible type IPS grooved-end pipe couplings, at side ports; allow full, 0.125 inch gap between port and piping, and position piping to maximize flexibility of connection.
- DO...provide flexibility in, and support for piping manifolds so that vessel can grow in length under pressure without undue restraint; provide additional flexible joints in large pipes leading to manifold header.
- DO...provide overpressure protection for vessel set at not more than 105% of design pressure
- DO...inspect end closures regularly; replace components that have deteriorated and correct causes of corrosion
- DO... Lubricate seals sparingly, using nonpetroleum Based lubricants, i.e. Parker Super O-lube®, Glycerin or suitable silicone based lubricants.
- DO NOT...work on any component until first verifying that pressure is relieved from vessel
- DO NOT...make rigid piping connections to ports or clamp vessel in any way that resists growth of fiberglass shell under pressure;
 ***ΔDIA = 0.015 in. (0.4mm) and
 ***ΔL = 0.2 in. (6mm) for a length code –8 vessel
- DO NOT... hang piping manifolds from ports or use vessel in any way to support other components
- DO NOT...tighten Permeate Port connection more than one turn past hand tight
- DO NOT... operate vessel without connecting both Permeate Ports internally to complete set of elements or otherwise plug ports internally so that external piping connection is not subjected to feed pressure
- DO NOT...install Spacer on downstream end of vessel
- DO NOT...operate vessel without Thrust Cone installed downstream
- DO NOT...pressurize vessel until double-checking to verify that the Locking Ring is in place and fully seated.
- DO NOT...operate vessel at pressure and temperature in excess of its rating.
- DO NOT...operate vessel with permeate pressure in excess of 125 psi at 190°F (0.86 Mpa at 88°C).
- DO NOT...tolerate leaks or allow end closures to be routinely wetted in any way
- DO NOT...operate outside the pH range 3-11.

ORDERING:

Using the chart below, please check the features you require

VESSEL LENGTH CODE – please check one

MODEL 80H45 -1 -2 -3 -4 -5 -6 -7 -8

MEMBRANE BRAND AND MODEL

Please supply adapters for the following membrane brand and specific model
 Brand _____ Model _____

CERTIFICATION REQUIRED

- ASME Stamped and National Board Registered.
- CE Marked Standard.
- Certified by Pentair water.
- In compliance with the ASME Sec X but not Code Stamped.
 - Hydro testing at 1.1 times the design pressure
 - Hydro testing at 1.5 times the design pressure

ADAPTER KITS	
UP STREAM	DOWN STREAM

PERMEATE PORT SELECTION

Serial Number End

Size of the Permeate Port 1” 1.25” 1.5”
 Type of Connection FNPT MNPT BSPTM BSPTF IPS GROOVED
 Material of Construction Noryl SS316L Zeron 100

Non Serial Number End

Size of the Permeate Port 1” 1.25” 1.5”
 Type of Connection FNPT MNPT BSPTM BSPTF IPS GROOVED
 Material of Construction Noryl SS316L Zeron 100

Note:

- Standard offering is 1.0” FNPT in Noryl.
- 1.25” & 1.5” BSPTF, 1.25” & 1.5” FNPT connections cannot be offered

STRAP ASSEMBLY

Standard SS304 Optional SS316 Optional SS316L

FEED/CONCENTRATE PORT SELECTION

Material of Construction CF3M Optional Duplex SS (CD3MN)
 Optional Super Duplex SS (CD3MWCuN)

Configuration Standard - CF3M 1G5G
 Optional –Multi port: (Refer SPEC.SHEET/PM/1.5”-3” for Multi ports selection).
 Ports not available in 90° configurations.

Serial number end

Opposite end

BEARING PLATE MATERIAL

Standard – 6061 T6 Aluminium
 Optional – Stainless Steel 316L

Note: Refer page-3 for optional Part numbers.

PORT SIZE CODE	
D	1½” GROOVED END
E	2” GROOVED END
F	2½” GROOVED END
G	3” GROOVED END

4

3

2

1

BEARING PLATE PART NUMBERS		
PERMEATE PORT SIZE	ALUMINIUM	SS316L
1.0"/1.25"	96157	96476
1.5"	96411	97373

SEALING PLATE PART NUMBERS	
Standard used for Aluminium BP	96159
Optional used for SS316L BP	97404

PERM PORT RETAINER RING & PORT NUT PART NUMBERS		
1.0" / 1.25"	Standard Port nut	45066
1.5"	Port Retainer Ring	45247

STRAP ASSEMBLY PART NUMBERS		
SS304	SS316	SS316L
45042	46926	94371

F/C PORT & SEAL PART NUMBER				
SIZE	*CF3M	**CD3MN	***CD3MWCuN	SEAL
3"	96120	97408	96327	96119
2.5"	96229	97407	96385	96079
2.0"	96485	97406	96645	96078
1.5"	96564	97405	96469	96077

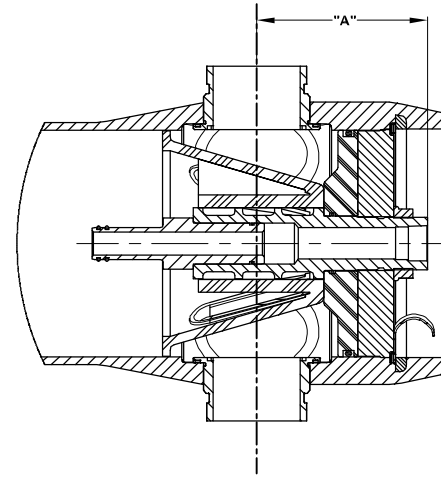

SECTION THROUGH END CLOSURE

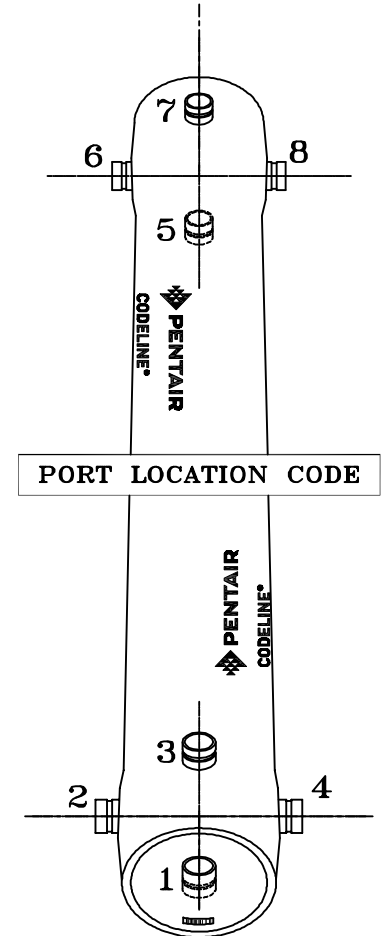

PORT LOCATION CODE

Serial Number End

PERMEATE PORT PART NUMBERS & PERMPORT TO F/C PORT OFFSET DISTANCE											
SIZE	MATERIAL	FNPT		MNPT		BSPTF		BSPTM		IPS GROOVED	
		PART NUMBER	DIM "A"	PART NUMBER	DIM "A"	PART NUMBER	DIM "A"	PART NUMBER	DIM "A"	PART NUMBER	DIM "A"
1.0"	NORYL	96161	6.008	97378	7.008	97664	6.008	97384	7.008	97689	7.238
	SS316L	97247	6.008	97379	7.008	97382	6.008	97385	7.008	97388	7.308
	#ZERON 100	97295	6.008	97380	7.008	97383	6.008	97386	7.008	97389	7.308
1.25"	NORYL	NA	NA	97665	7.008	NA	NA	97666	7.008	97667	7.238
	SS316L	NA	NA	97390	7.008	NA	NA	97392	7.008	97167	7.308
	#ZERON 100	NA	NA	97391	7.008	NA	NA	97393	7.008	97395	7.308
1.5"	NORYL	NA	NA	97668	6.608	NA	NA	97399	6.608	97669	7.238
	SS316L	NA	NA	97397	6.608	NA	NA	97400	6.608	97448	7.238
	#ZERON 100	NA	NA	97398	6.608	NA	NA	97401	6.608	97403	7.238

NOTES

DIMENSION IN INCHES (MM APPROX.)

- * GRADE CF3M PER ASME SA-351/316L AS PER SA-479
- ** GRADE CD3MN AS PER ASME SPEC SA-995 (UNS-J92205)
- *** GRADE CD3MWCuN AS PER ASME SPEC SA-995 (J 93380)
- # GRADE ZERON 100 AS PER ASME SPEC SA-479.

Distributed By:

APPLIED MEMBRANES INC.[®]

Industry Leader in RO Expertise and Membrane Applications since 1983™

2450 Business Park Dr., Vista, CA 92081 ☎ (760) 727-3711 📠 (760) 727-4427
 🌐 www.appliedmembranes.com ✉ sales@appliedmembranes.com

DRAWN	KPS	MODEL - 80H45			
	16 OCT 10	MEMBRANE HOUSING			
CHECKED	RD	DATE	DWG. NO.	REV.	P
	16 OCT 10	25APR14	99167		
APPROVED	RM	ECN	SCALE	SIZE	SHEET
	16 OCT 10	3236	NONE	A3	3 OF 3

4

3

2

1