

1000  
PSI

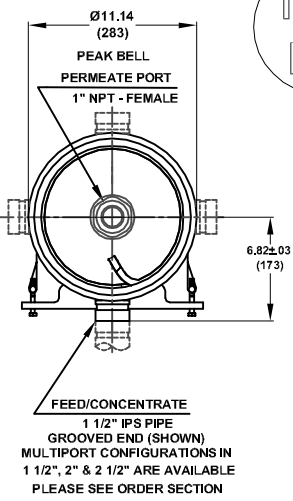

DWG REF	QTY	PART NUMBER	DESCRIPTION	MATERIAL
<b>SHELL</b>				
1	1	ORDER SECTION	SHELL	Filament Wound Epoxy/Glass composite - Head locking grooves integrally wound in place.
2	A/R		F/C Port	CD3MWCuN *
3	A/R		F/C Port Seal	Ethylene Propylene
<b>HEAD</b>				
4	2	96158	Bearing Plate	6061-T6 Aluminium alloy - Hard anodized*
5	2	96160	Sealing Plate	Engineering Thermoplastic.
6	2	96162	Permeate Port	Engineering Thermoplastic.
7	2	45066	Port Nut	Engineering Thermoplastic.
8	2	96000	Head Seal	Ethylene Propylene - O - Ring
9	2	45312	Perm Port Seal	Ethylene Propylene - O - Ring
<b>HEAD INTERLOCK</b>				
10	2	47336	Quick Release Spiral Ring	316 Stainless Steel.
<b>VESSEL SUPPORT</b>				
11	2*	52169	Saddle	Engineering Thermoplastic.
12	2*	45042	Strap Assy.	304 Stainless Steel-PVC Cushion.
13	4	46265	Strap screw.	5/16-18 UNC, 18-8 Stainless Steel.
<b>ELEMENT INTERFACE</b>				
14	2	A/R	Adapter	Engineering Thermoplastic.
15	2	52245	Adapter seal	Ethylene Propylene - O - Ring
16	4	A/R	PWT Seal	Ethylene Propylene - O - Ring
17	1	96163	Thrust Cone	Engineering Thermoplastic.
*3 each furnished with length code 4,5,6,7 & 8.				

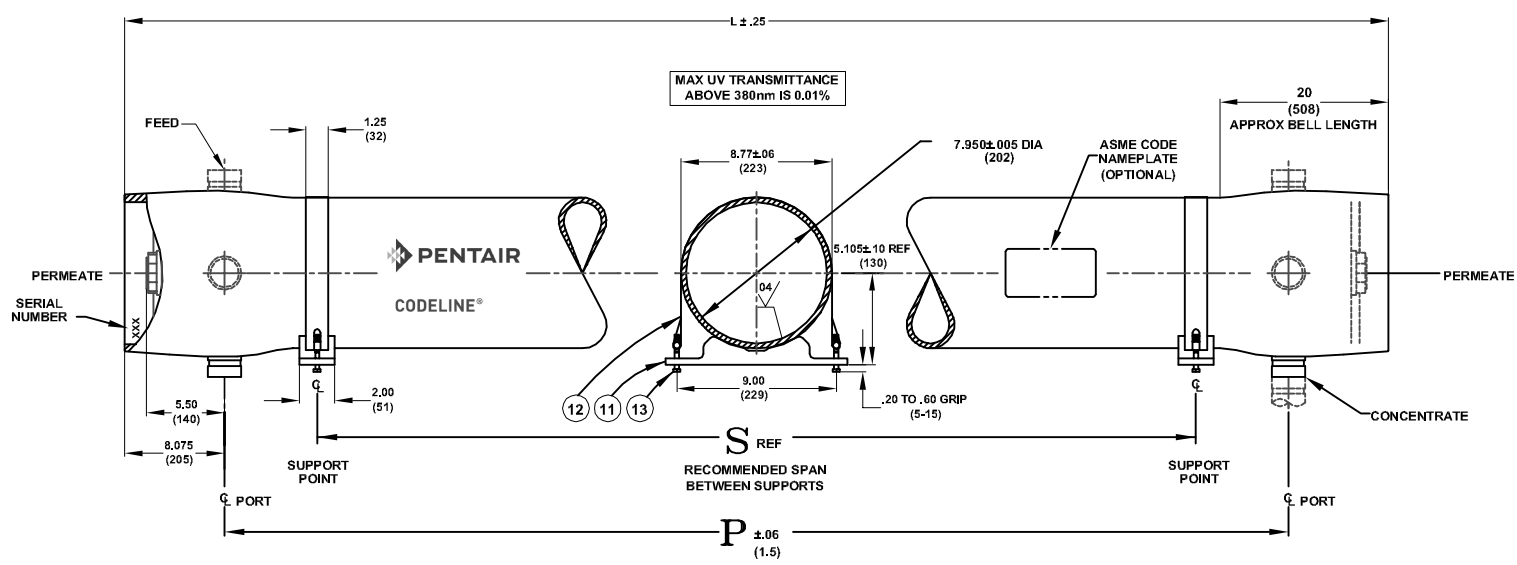
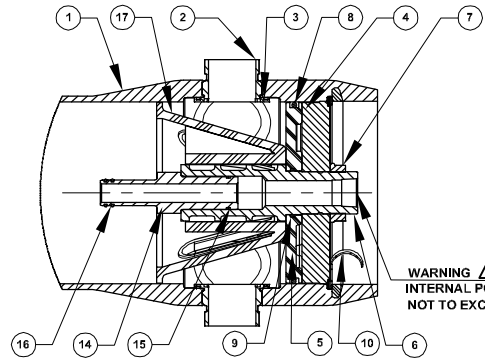

NOTES:-

- ◆ MAX. ANGULAR VARIATION BETWEEN ANY PORTS ±0.5°.
- ◆ DIMENSION IN INCHES (MM APPROX.)
- ◆ SHELL EXTERIOR COATED WITH WHITE, HIGH GLOSS POLYURETHANE PAINT.
- ◆ ITEM 17 DOWNSTREAM ONLY.
- ◆ NOT TO BE USED FOR CONSTRUCTION UNLESS CERTIFIED.
- ◆ GRADE CD3MWCuN AS PER ASME SA-995 (J93380).
- ◆ # 600 PSI FOR METALLIC PERMPORTS
- \* FOR OPTIONAL PART NUMBERS REFER PAGE 3
- \*\* WEIGHTS GIVEN IN THE TABLE ARE FOR HIGHEST CONFIGURATION AND WILL VARY WITH CHANGE IN CONFIGURATION.

CAUTION: INCORRECT MANIFOLDING WILL CAUSE SEVERE LOCAL STRESS AROUND PORT AND MAY RESULT IN LEAKS AND PREMATURE FAILURE; TAKE EVERY PRECAUTION LISTED ON REVERSE, SEE INSTALLATION INSTRUCTIONS FOR FURTHER DETAILS

PO NUMBER	
CUSTOMER NAME	
PROJECT NAME	
TOTAL QUANTITY	

PORT CONFIGURATION DETAILS	
PORT CONFIG	VESSEL QUANTITY

Dash Length	L IN(MM)	P IN(MM)	S IN(MM)	Approx Weight LB(KG)
-1	63.15 (1604)	47 (1194)	19X1 (486)	127 (58)
-2	103.15 (2620)	87 (2210)	56X1 (1422)	160 (73)
-3	143.15 (3636)	127 (3226)	80X1 (2032)	192 (87)
-4	183.15 (4652)	167 (4242)	64X2 (1626)	226 (103)
-5	223.15 (5668)	207 (5258)	78X2 (1981)	259 (117)
-6	263.15 (6684)	247 (6274)	92X2 (2337)	286 (130)
-7	303.15 (7700)	287 (7290)	106X2 (2692)	319 (145)
-8	343.15 (8716)	327 (8306)	120X2 (3048)	350 (159)

**PENTAIR**  
CODELINE®

MODEL - 80S100  
MEMBRANE HOUSING

DRAWN DATE	PGS 02 SEP 05
CHECKED DATE	MD 02 SEP 05
APPROVED DATE	RM 02 SEP 05

ECN 3121	DWG. NO. 99163	REV. M
DATE 10JAN14	SCALE NONE	SIZE A3
		SHEET 1 OF 3

**RATING:**

DESIGN PRESSURE.....1000 PSIG at 150°F  
 (6.9 MPa at 66°C)  
 MIN. OPERATING TEMP.....20°F  
 (-7°C)  
 FACTORY TEST PRESSURE...1500 PSIG/1100 PSIG  
 (10.34 MPa)/ (7.58 MPa)  
 QUALIFICATION PRESSURE .....6000 PSI  
 (41.37 MPa)

**INTENDED USE:**

The CodeLine 80S100 Fiberglass RO Pressure Vessel is designed for continuous, long term use as housing for reverse osmosis membrane elements to desalt typical brackish waters at pressures up to 1000 psi. Any make of eight-inch nominal diameter spiral-wound element is easily accommodated; the appropriate interfacing hardware for the element specified is furnished with the vessel.

The CodeLine 80S100 is designed in accordance with the engineering standards of the Boiler and Pressure Vessel Code of the American Society of Mechanical Engineers (ASME) Code. At small additional cost vessels can be inspected during construction by an ASME Authorized Inspector and ASME Code stamped.

The CodeLine 80S100 must be installed, operated and maintained in accordance with the listed precautions and good industrial practice to assure safe operation over a long service life.

The high performance Filament wound FRP shell must be allowed to expand under pressure; undue restraint at support points or piping connections can cause leaks to develop in the shell. This side-ported vessel requires special precautions in mounting and connection to piping so that the vessel will not be subjected to excessive stress due to bending moments acting at the side openings in the fiberglass shell. The end closure, incorporating close fitting, interlocking metal components, must be kept dry and free of corrosion; deterioration can lead to catastrophic mechanical failure of the head.

Pentair Water will assist the purchaser in determining the suitability of this standard vessel for their specific operating conditions. The final determination however, including evaluation of the standard material of construction for compatibility with the specific corrosive environment, shall be the responsibility of the purchaser. Alternate materials with enhanced corrosion resistance are available on special order.

Specifications are subject to change without notice.

**PRECAUTIONS:**

- DO...read, understand and follow all instructions; failure to take every precaution will void warranty and may result in vessel failure
- DO...mount the shell on horizontal members at span “S” using compliant vessel supports furnished; Shim saddles if required. Tighten hold down straps just snug
- DO...align and center side ports with the manifold header. Correct, causes of misalignment in a row of vessels connected to the same header
- DO...use flexible type IPS grooved-end pipe couplings, at side ports; allow full, 0.125 inch gap between port and piping, and position piping to maximize flexibility of connection.
- DO...provide flexibility in, and support for piping manifolds so that vessel can grow in length under pressure without undue restraint; provide additional flexible joints in large pipes leading to manifold header.
- DO...provide overpressure protection for vessel set at not more than 105% of design pressure
- DO...inspect end closures regularly; replace components that have deteriorated and correct causes of corrosion
- DO... Lubricate seals sparingly, using nonpetroleum Based lubricants, i.e. Parker Super O-lube®, Glycerin or suitable silicone based lubricants.
- DO NOT...work on any component until first verifying that pressure is relieved from vessel
- DO NOT...make rigid piping connections to ports or clamp vessel in any way that resists growth of fiberglass shell under pressure;  
 \*\*\*ΔDIA = 0.015 in. (0.4mm) and  
 \*\*\*ΔL = 0.2 in. (6mm) for a length code –8 vessel
- DO NOT... hang piping manifolds from ports or use vessel in any way to support other components
- DO NOT...tighten Permeate Port connection more than one turn past hand tight
- DO NOT... operate vessel without connecting both Permeate Ports internally to complete set of elements or otherwise plug ports internally so that external piping connection is not subjected to feed pressure
- DO NOT...install Spacer on downstream end of vessel
- DO NOT...operate vessel without Thrust Cone installed downstream
- DO NOT...pressurize vessel until double-checking to verify that the Locking Ring is in place and fully seated.
- DO NOT...operate vessel at pressure and temperature in excess of its rating.
- DO NOT...operate vessel with permeate pressure in excess of 125 psi at 150°F (0.86 Mpa at 66.°C).
- DO NOT...tolerate leaks or allow end closures to be routinely wetted in any way
- DO NOT...operate outside the pH range 3-10.

**ORDERING:**

Using the chart below, please check the features you require

**VESSEL LENGTH CODE – please check one**

MODEL 80S100  -1  -2  -3  -4  -5  -6  -7  -8

**MEMBRANE BRAND AND MODEL**

Please supply adapters for the following membrane brand and specific model  
 Brand \_\_\_\_\_ Model \_\_\_\_\_

**CERTIFICATION REQUIRED**

- ASME Stamped and National Board Registered.
- CE Marked Standard.
- Certified by Pentair water.
- In compliance with the ASME Sec X but not Code Stamped.
  - Hydro testing at 1.1 times the design pressure
  - Hydro testing at 1.5 times the design pressure

ADAPTER KITS	
UP STREAM	DOWN STREAM

**PERMEATE PORT SELECTION**

Serial Number End

Size of the Permeate Port  1”  1.25”  1.5”  
 Type of Connection  FNPT  MNPT  BSPTM  BSPTF  IPS GROOVED  SANITARY  
 Material of Construction  Noryl  SS316L  Zeron 100

Non Serial Number End

Size of the Permeate Port  1”  1.25”  1.5”  
 Type of Connection  FNPT  MNPT  BSPTM  BSPTF  IPS GROOVED  SANITARY  
 Material of Construction  Noryl  SS316L  Zeron 100

**Note:**

- Standard offering is 1.0” FNPT in Noryl.
- 1.25” & 1.5” BSPTF, 1.25” & 1.5” FNPT and 1.25” SANITARY connections cannot be offered
- Sanitary permeate port cannot be offered in Noryl

**STRAP ASSEMBLY**

Standard SS304  Optional SS316  Optional SS316L

**FEED/CONCENTRATE PORT SELECTION**

Material of Construction  STD - Super Duplex SS (CD3MWCuN)  
 Optional - CE3MN

Configuration  Standard – CD3MWCuN 1D5D

Optional –Multi port: (Refer SPEC.SHEET/PM/1.5”-3” for Multi ports selection).  
 1.5”, 2”, 2.5” Ports not available in 90° configurations.

Serial number end          
 Opposite end

PORT SIZE CODE	
D	1½” GROOVED END
E	2” GROOVED END
F	2½” GROOVED END

**BEARING PLATE MATERIAL**

Standard – 6061 T6 Aluminium  
 Optional – Stainless Steel 316L

**Note:** Please refer to 99376 for sanitary details and refer page-3 for optional Part numbers.

4

3

2

1

BEARING PLATE PART NUMBERS		
PERMEATE PORT SIZE	ALUMINIUM	SS316L
1.0"/1.25"	96158	96475
1.5"	96343	97370

SEALING PLATE PART NUMBERS	
Standard used for Aluminium BP	96160
Optional used for SS316L BP	96477

PERM PORT RETAINER RING & PORT NUT PART NUMBERS		
1.0" / 1.25"	Standard Port nut	45066
1.5"	Port Retainer Ring	45247

STRAP ASSEMBLY PART NUMBERS		
SS304	SS316	SS316L
45042	46926	94371

F/C PORT & SEAL PART NUMBER			
SIZE	***CD3MWCuN	**CE3MN	SEAL
1.5"	96469	96725	96077
2.0"	96645	96907	96078
2.5"	96385	96954	96079

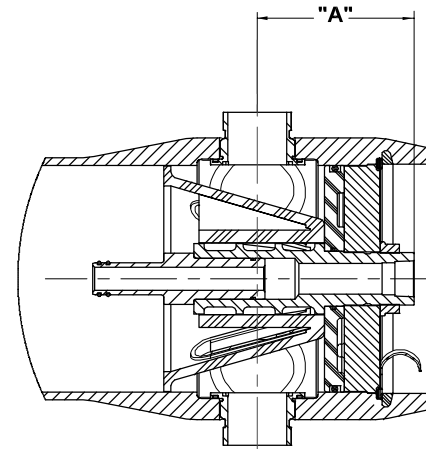

SECTION THROUGH END CLOSURE

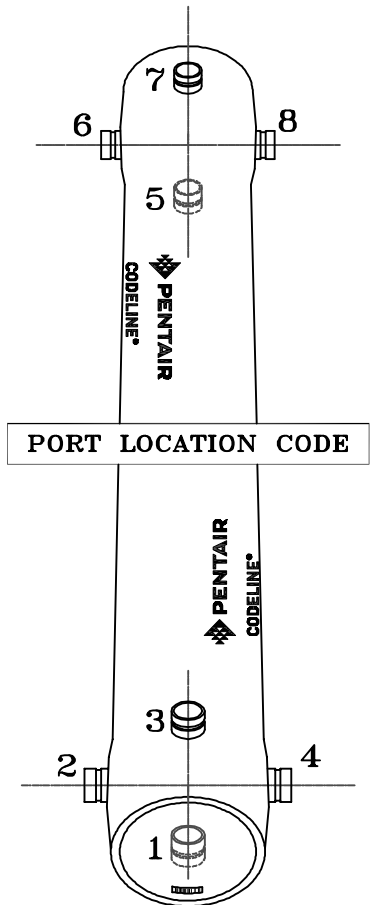

PORT LOCATION CODE

Serial Number End

PERMEATE PORT PART NUMBERS & PERMPORT TO F/C PORT OFFSET DISTANCE											
SIZE	MATERIAL	FNPT		MNPT		BSPTF		BSPTM		IPS GROOVED	
		PART NUMBER	DIM "A"	PART NUMBER	DIM "A"	PART NUMBER	DIM "A"	PART NUMBER	DIM "A"	PART NUMBER	DIM "A"
1.0"	NORYL	96162	5.508	97659	6.508	96301	5.508	97660	6.508	97661	6.808
	SS316L	96752	5.508	97347	6.508	97351	5.508	97355	6.508	97322	6.808
	#ZERON 100	97349	5.508	97348	6.508	97352	5.508	97356	6.508	97293	6.808
1.25"	NORYL	NA	NA	97655	6.508	NA	NA	97360	6.508	97662	6.808
	SS316L	NA	NA	96487	6.508	NA	NA	97362	6.508	97311	6.808
	#ZERON 100	NA	NA	97359	6.508	NA	NA	97363	6.508	97365	6.808
1.5"	NORYL	NA	NA	97663	6.108	NA	NA	97369	6.108	97656	6.738
	SS316L	NA	NA	97368	6.108	NA	NA	97371	6.108	97449	6.738
	#ZERON 100	NA	NA	97292	6.108	NA	NA	97372	6.108	97374	6.738

## NOTES

" DIMENSION IN INCHES (MM APPROX.)

\*\* GRADE CE3MN AS PER ASME SPEC SA-995 (UNS-J93404)

\*\*\* GRADE CD3MWCuN AS PER ASME SPEC SA-995 (J 93380)

# GRADE ZERON 100 AS PER ASME SPEC SA-479.

Distributed By:

**APPLIED MEMBRANES INC.**  
 Industry Leader in RO Expertise and Membrane Applications since 1983™

2450 Business Park Dr., Vista, CA 92081 ☎ (760) 727-3711 📠 (760) 727-4427  
 www.appliedmembranes.com ✉ sales@appliedmembranes.com

DRAWN	PDM	MODEL - 80S100			
	27 JUN 11	MEMBRANE HOUSING			
CHECKED	RD	DATE	DWG. NO.	REV.	
	27 JUN 11	10JAN14	99163	M	
APPROVED	RM	ECN	SCALE	SIZE	SHEET
	27 JUN 11	3121	NONE	A3	3 OF 3

4

3

2

1