

## 5CP Stainless Steel Plunger Pump

**Models** 5CP6221  
5CP6241CS  
5CP6251

### FEATURES

#### Superior Design

- Triplex plunger design provides smoother liquid flow.
- Hi-Pressure Seals are completely lubricated and cooled by the liquid being pumped.
- Inlet and discharge valve assemblies interchange for easier maintenance.
- Lubricated Lo-Pressure Seal provides double protection against external leakage.
- Oil bath crankcase assures optimum lubrication.
- Close tolerance concentricity of the ceramic plunger maximizes seal life.

#### Quality Materials

- Precision design 316 stainless steel valves and seats are hardened and polished for ultimate seating and extended valve life.
- 316 stainless steel manifold is strong and corrosion resistant.
- Special concentric, high-density, polished, solid ceramic plungers provide a true wear surface and extended seal life.
- Specially formulated, CAT PUMP exclusive, Hi-Pressure Seals offer unmatched performance and seal life.
- Die cast aluminum crankcase provides high strength, minimum weight and precision tolerance control.
- Chrome-moly crankshaft gives unmatched strength and surface hardness.
- Oversized crankshaft bearings with greater capacity mean longer bearing life.

#### Easy Maintenance

- Wet-end is easily serviced without entering crankcase, requiring less time and effort.
- Preset packings mean no packing gland adjustment is necessary, reducing maintenance costs.

#### **⚠ WARNING**

All systems require both a primary pressure regulating device (i.e., regulator, unloader) and a secondary pressure safety relief device (i.e., pop-off valve, safety valve). Failure to install such relief devices could result in personal injury or damage to the pump or to system components. CAT PUMPS does not assume any liability or responsibility for the operation of a customer's high pressure system.

### SPECIFICATIONS

#### MODEL 5CP6221

	U.S. Measure	Metric Measure
Flow .....	6.0 GPM	(23 L/M)
Pressure Range .....	100 to 2000 PSI	(7 to 140 BAR)
Inlet Pressure Range .....	-5 to 60 PSI	(-0.35 to 4 BAR)
RPM .....	1400 RPM	(1400 RPM)
Stroke .....	0.709"	(18 mm)

#### MODEL 5CP6241CS Direct Drive

	U.S. Measure	Metric Measure
Flow .....	4.0 GPM	(15 L/M)
Pressure Range .....	100 to 2000 PSI	(7 to 140 BAR)
Inlet Pressure Range .....	Flooded to 60 PSI	(Flooded to 4 BAR)
RPM .....	1725 RPM	(1725 RPM)
Stroke .....	0.394"	(10 mm)

#### MODEL 5CP6251 Direct Drive

	U.S. Measure	Metric Measure
Flow .....	5.0 GPM	(19 L/M)
Pressure Range .....	100 to 2000 PSI	(7 to 140 BAR)
Inlet Pressure Range .....	Flooded to 60 PSI	(Flooded to 4 BAR)
RPM .....	1725 RPM	(1725 RPM)
Stroke .....	0.472"	(12 mm)

### COMMON SPECIFICATIONS

Bore .....	0.787"	(20 mm)
Crankcase Capacity .....	17 oz.	(0.53 L)
Maximum Liquid Temperature .....	160°F	(71°C)
Above 130°F call CAT PUMPS for inlet conditions and elastomer recommendations.		
Inlet Ports (2) .....	1/2" NPTF	(1/2" NPTF)
Discharge Ports (2) .....	3/8" NPTF	(3/8" NPTF)
Shaft Diameter .....	0.787"	(20 mm)
Weight .....	20 lbs.	(8 kg)
Dimensions .....	11.47 x 10.0 x 5.75"	(291.3 x 254 x 146 mm)

### ELECTRIC HORSEPOWER REQUIREMENTS

MODEL	FLOW		PRESSURE			RPM
	U.S. GPM	L/M	PSI 1200 BAR 85	PSI 1600 BAR 110	PSI 2000 BAR 140	
5CP6221	6.0	23	5.0	6.6	8.2	1400
	5.0	19	4.1	5.5	6.8	1208
	4.0	15	3.3	4.4	5.5	966
5CP6241CS	4.0	15	3.3	4.4	5.5	1725
5CP6251	5.0	19	4.1	5.5	6.8	1725

**DETERMINING THE PUMP R.P.M.**  $\frac{\text{Rated G.P.M.}}{\text{Rated R.P.M.}} = \frac{\text{"Desired" G.P.M.}}{\text{"Desired" R.P.M.}}$

**DETERMINING THE REQUIRED H.P.**  $\frac{\text{GPM} \times \text{PSI}}{1460} = \text{Electric Brake H. P. Required}$

**DETERMINING MOTOR PULLEY SIZE**  $\frac{\text{Motor Pulley O.D.}}{\text{Pump R.P.M.}} = \frac{\text{Pump Pulley O.D.}}{\text{Motor R.P.M.}}$

See complete Drive Packages [Inclds: Pulleys, Belts, Hubs, Key] Tech Bulletin 003. Refer to pump **Service Manual** for repair procedure, additional technical information and **pump warranty**.

*"Customer confidence is our greatest asset"*

# PARTS LIST

ITEM	PART NUMBER		PART NUMBER		PART NUMBER		DESCRIPTION	QTY
	5CP6221	MATL	5CP6241CS	MATL	5CP6251	MATL		
2	30057	STL	30057	STL	30057	STL	Key (M6x6x25)	1
5	119049	SS	119049	SS	119049	SS	Screw, HHC, Sems (M8x16)	8
8	46910	AL	46910	AL	46910	AL	Cover, Bearing	2/1
10	14028	NBR	14028	NBR	14028	NBR	O-Ring, Cover, Bearing - 70D	2/1
11	43222	NBR	43222	NBR	43222	NBR	Seal, Oil, Crankshaft - 70D	2
15	14480	STL	14480	STL	14480	STL	Bearing, Ball	2
20	48742	TNM	48742	TNM	48742	TNM	Rod Assy, Connecting [10/01]	3
25	46928	FCM	—	—	46982	FCM	Crankshaft, Dual End	1
	—	—	48203	FCM	—	—	Crankshaft, Single End	1
30	—	—	48224	AL	—	—	Cover, Blind Bearing	1
32	46798	—	46798	—	46798	—	Cap, Oil Filler	1
33	14179	NBR	14179	NBR	14179	NBR	O-Ring, Oil Filler Cap - 70D	1
37	92241	—	92241	—	92241	—	Gauge, Oil, Bubble w/Gasket - 80D	1
38	44428	NBR	44428	NBR	44428	NBR	Gasket, Flat, Oil Gauge - 80D	1
40	92538	S	92538	S	92538	S	Screw, HHC, Sems (M6x16)	4
48	25625	STCP	25625	STCP	25625	STCP	Plug, Drain (1/4X19BSP)	1
49	23170	NBR	23170	NBR	23170	NBR	O-Ring, Drain Plug - 70D	1
50	46940	AL	46940	AL	46940	AL	Cover, Rear	1
51	14044	NBR	14044	NBR	14044	NBR	O-Ring, Cover, Rear	1
53	48617	AL	48617	AL	48617	AL	Crankcase	1
64	46746	CM	46746	CM	46746	CM	Pin, Crosshead	3
65	48458	BBNP	48458	BBNP	48458	BBNP	Rod, Plunger	3
70	46838	NBR	46838	NBR	46838	NBR	Seal, Oil, Crankcase - 70D	3
71	48208	PVDF	48208	PVDF	48208	PVDF	Washer, Oil Seal	3
75	43328	S	43328	S	43328	S	Slinger, Barrier	3
88	45697	S	45697	S	45697	S	Washer, Keyhole (M18)	3
90	46841	CC	46841	CC	46841	CC	Plunger (M20x50)	3
98	46730	NBR	46730	NBR	46730	NBR	Washer, Seal - 90D	3
	48394	FPM	48394	FPM	48394	FPM	Washer, Seal - 90D	3
	◆ 48432	EPDM	◆ 48432	EPDM	◆ 48432	EPDM	Washer, Seal	3
99	† 48201	SSL	† 48201	SSL	† 48201	SSL	Retainer, Plunger (M6x30)	3
100	46749	PVDF	46749	PVDF	46749	PVDF	Retainer, Seal	3
106	44127	NBR	44127	NBR	44127	NBR	Seal, LPS w/SS-Spg	3
	45153	FPM	45153	FPM	45153	FPM	Seal, LPS w/SS-Spg	3
	◆ 48429	EPDM	◆ 48429	EPDM	◆ 48429	EPDM	Seal, LPS w/SS-Spg, 2-Pc w/S Support	3
110	48552	SS	48552	SS	48552	SS	Manifold, Inlet	1
117	119034	S	119034	S	119034	S	Screw, HSH (M8x35)	4
125	44649	SNG	44649	SNG	44649	SNG	Seal, HPS w/SS	3
	44936	FPM	44936	FPM	44936	FPM	Seal, HPS w/SS	3
	46667	HT	46667	HT	46667	HT	Seal, HPS w/S	3
143	17615	NBR	17615	NBR	17615	NBR	O-Ring, I.V. Adapter, Rear - 75D	3
	15855	FPM	15855	FPM	15855	FPM	O-Ring, I.V. Adapter, Rear - 70D	3
	◆ 48431	EPDM	◆ 48431	EPDM	◆ 48431	EPDM	O-Ring, I.V. Adapter, Rear - 75D	3
150	48212	SSL	48212	SSL	48212	SSL	Adapter, Inlet	3
154	43781	NBR	43781	NBR	43781	NBR	O-Ring, I.V. Adapter, Front - 75D	3
	11337	FPM	11337	FPM	11337	FPM	O-Ring, I.V. Adapter, Front - 75D	3
	◆ 48430	EPDM	◆ 48430	EPDM	◆ 48430	EPDM	O-Ring, I.V. Adapter, Front - 75D	3
155	43781	NBR	43781	NBR	43781	NBR	O-Ring, D.V. Adapter, Rear - 75D	3
	11337	FPM	11337	FPM	11337	FPM	O-Ring, D.V. Adapter, Rear - 75D	3
	◆ 48430	EPDM	◆ 48430	EPDM	◆ 48430	EPDM	O-Ring, D.V. Adapter, Rear - 75D	3
157	48211	SSL	48211	SSL	48211	SSL	Adapter, Discharge	3
159	43781	NBR	43781	NBR	43781	NBR	O-Ring, D.V. Adapter, Front - 75D	3
	11337	FPM	11337	FPM	11337	FPM	O-Ring, D.V. Adapter, Front - 75D	3
	◆ 48430	EPDM	◆ 48430	EPDM	◆ 48430	EPDM	O-Ring, D.V. Adapter, Front - 75D	3
163	43781	NBR	43781	NBR	43781	NBR	O-Ring, Seat - 75D	3
	11337	FPM	11337	FPM	11337	FPM	O-Ring, Seat - 75D	3
	◆ 48430	EPDM	◆ 48430	EPDM	◆ 48430	EPDM	O-Ring, Seat - 75D	3
164	48216	SSL	48216	SSL	48216	SSL	Seat	6
165	43793	NBR	43793	NBR	43793	NBR	O-Ring, Seat - 90D	6
	43791	FPM	43791	FPM	43791	FPM	O-Ring, Seat - 90D	6
	◆ 48490	EPDM	◆ 48490	EPDM	◆ 48490	EPDM	O-Ring, Seat - 90D	6
166	44038	SSL	44038	SSL	44038	SSL	Valve	6
167	44039	SS	44039	SS	44039	SS	Spring	6
168	44564	PVDF	44564	PVDF	44564	PVDF	Retainer, Spring	6
185	48554	SS	48554	SS	48554	SS	Manifold, Discharge	1
186	19085	S	19085	S	19085	S	Lockwasher, Split (M12)	6
188	120774	S	120774	S	120774	S	Screw, HSH (M12x40)	2
189	89575	S	89575	S	89575	S	Screw, HSH (M12x60)	4
250	118672	STCP	118672	STCP	118672	STCP	Protector, Shaft	1
260	30611	STZP	30611	STZP	30611	STZP	Mount, Rail Assy	1
269	—	—	—	—	—	—	Pulley [See Drive Packages, Tech Bulletin 003]	1
270	30944	STL	—	—	—	—	Hub and Key Assy [See Drive Packages, Tech Bulletin 003]	1
278	—	—	8230	AL	8235	AL	Flex Coupling Assy (M20 to 1-1/8" or 1")	1
279	—	—	34424	AL	34424	AL	Bell Housing Assy (184TC, 10 hp)	1
280	—	—	—	—	—	—	BD Direct Drive Motor [See Individual Data Sheet]	1
283	34334	—	34334	—	34334	—	Kit, Oil Drain	1
290	6124	—	6124	—	6124	—	Gasket, Liquid (3.0 oz.)	1
299	816720	SS	816720	SS	816720	SS	Head, Complete	1
300	34353	NBR	34353	NBR	34353	NBR	Kit, Seal (Incls: 98,106,125,143,154,155,159)	1
	34351	FPM	34351	FPM	34351	FPM	Kit, Seal (Incls: 98,106,125,143,154,155,159)	1
	◆ 34352	EPDM	◆ 34352	EPDM	◆ 34352	EPDM	Kit, Seal (Incls: 98,106,125,143,154,155,159)	1

# EXPLODED VIEW

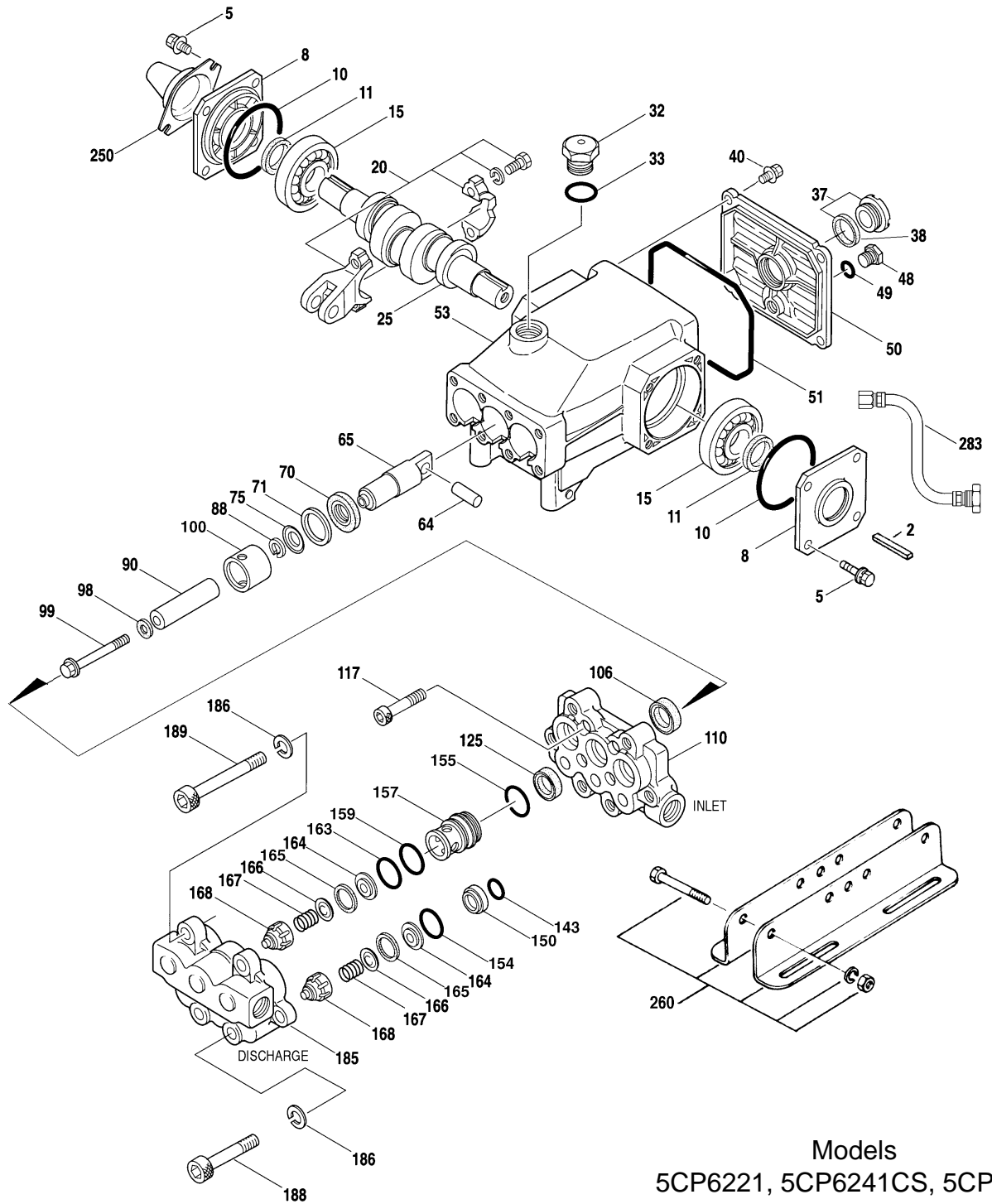

Models  
5CP6221, 5CP6241CS, 5CP6251  
May 2008

	5CP6221	MATL	5CP6241CS	MATL	5CP6251	MATL		
310	33972	NBR	33972	NBR	33972	NBR	Kit, Valve (Incls: 143,154,163,164,165,166,167,168)	1
	34362	FPM	34362	FPM	34362	FPM	Kit, Valve (Incls: 143,154,163,164,165,166,167,168)	1
	◆ 34363	EPDM	◆ 34363	EPDM	◆ 34363	EPDM	Kit, Valve (Incls: 143,154,163,164,165,166,167,168)	1
—	711500	SS	711500	SS	711500	SS	C.A.T. (Inlet pressure stabilizer for RO and boosted inlet applications)	1
—	711502	SS	711502	SS	711502	SS	Adapter (2 per C.A.T.) (See Data Sheet for complete selection)	2
—	6107	—	6107	—	6107	—	Oil, Bottle (21 oz.) ISO 68 Multi-Viscosity Hydraulic	1
							(Fill to specified crankcase capacity prior to start-up)	
—	6119	—	6119	—	6119	—	Lubricant, Antiseize (1.0 oz.)	1

**Bold print part numbers are unique to a particular pump model.** *Italics are optional items.* [ ] Date of latest production change.

◆ Silicone oil/grease required. † Production parts are different than repair parts.

See Tech Bulletins 002, 003, 024, 036, 043, 053, 056, 074, 077, 083, 088 and 095 for additional information.

MATERIAL CODES (Not Part of Part Number): AL=Aluminum BBNP=Brass/Nickel Plated CC=Ceramic CM=Chrome-moly  
EPDM=Ethylene Propylene Diene Monomer FCM=Forged Chrome-Moly FPM=Fluorocarbon HT=Hi-Temp (EPDM Alternative)  
NBR=Medium Nitrile (Buna-N) PVDF=Polyvinylidene Fluoride S=304SS SS=316SS SSL=316SS/Low Carbon SNG=Special Blend (Buna)  
STCP=Steel/Chrome Plated STZP=Steel/Zinc Plated STL=Steel TNM=Special High Strength

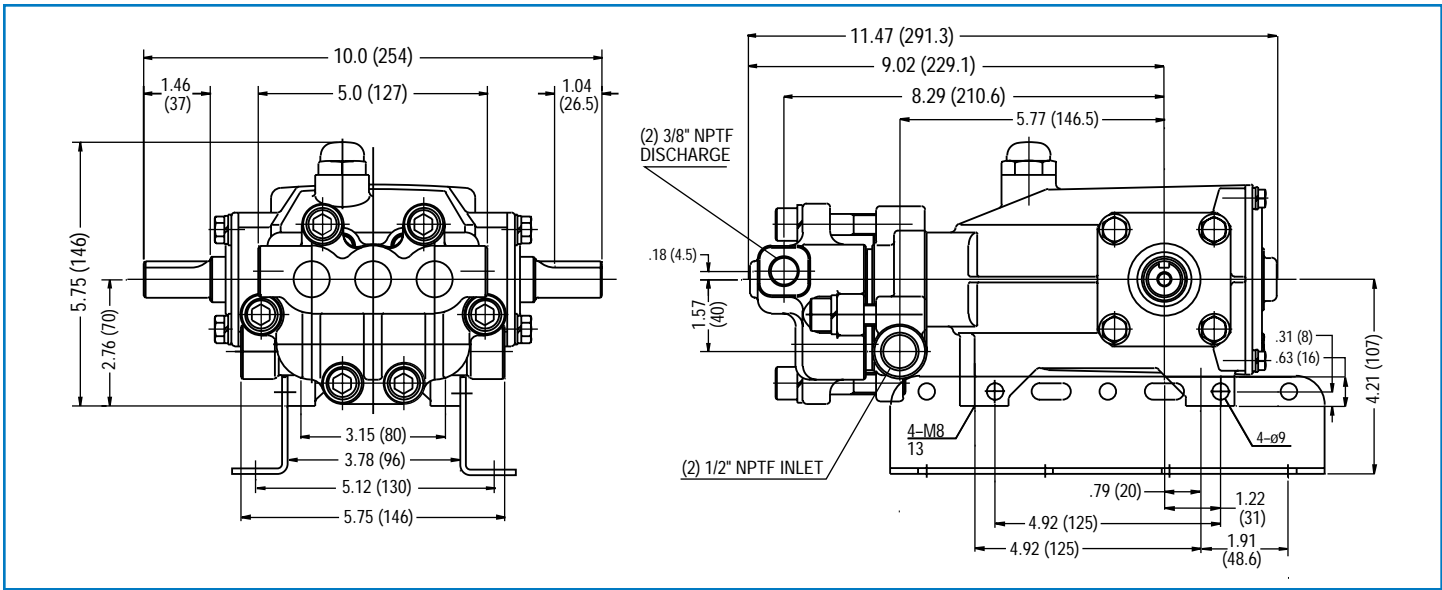

Models 5CP6221, 5CP6241CS, 5CP6251

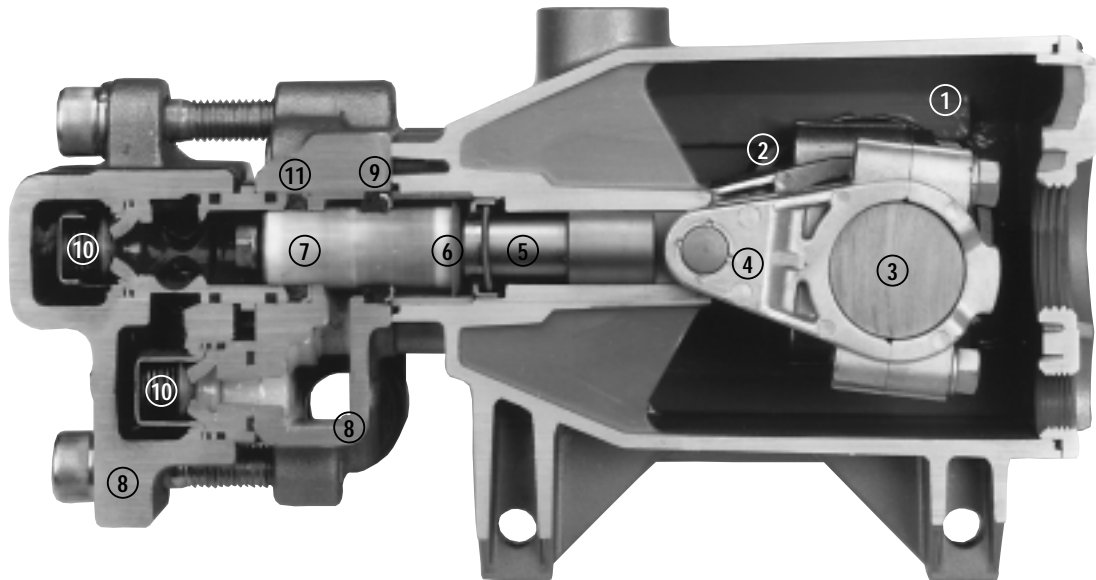

- 1 Die cast aluminum **crankcase** means high strength, lightweight, and excellent tolerance control.
- 2 Oversized crankshaft **bearings** provide extended bearing life and pump performance.
- 3 Chrome-moly **crankshaft** provides unmatched strength and surface hardness for long life.
- 4 Matched oversized TNM **connecting rods** noted for superior tensile strength and bearing quality.
- 5 The **plunger rods** are hardened, surface plated for wear resistance, with high load capacity.
- 6 The stainless steel **slinger** provides back-up protection for the crankcase seal, keeping pumped liquids out of the crankcase.
- 7 Special concentric, high-density, polished, solid ceramic **plungers** provide a true wear surface and extended seal life.
- 8 **Manifolds** are high tensile strength 316 stainless steel for liquid compatibility and long term, continuous duty.
- 9 100% wet **seal** design adds to service life by allowing pumped liquids to cool and lubricate on both sides.
- 10 316 stainless steel **valves, seats and springs** provide corrosion-resistance, ultimate seating and extended life.
- 11 Specially formulated, CAT PUMP exclusive, **Hi-Pressure Seals** offer unmatched performance and seal life.

Products described hereon are covered by one or more of the following U.S. patents 3558244, 3652188, 3809508, 3920356, 3930756 and 5035580

**World Headquarters**  
**CAT PUMPS**  
 1681 - 94th Lane N.E. Minneapolis, MN 55449-4324  
 Phone (763) 780-5440 — FAX (763) 780-2958  
 e-mail: techsupport@catpumps.com  
 www.catpumps.com



**CAT PUMPS (U.K.) LTD.**  
 1 Fleet Business Park, Sandy Lane, Church Crookham  
 FLEET, Hampshire, GU52 8BF, England  
 Phone Fleet 44 1252-622031 — Fax 44 1252-626655  
 e-mail: sales@catpumps.co.uk

**N.V. CAT PUMPS INTERNATIONAL S.A.**  
 Heiveldekens 6A, B-2550 Kontich, Belgium  
 Phone 32-3-450.71.50 — Fax 32-3-450.71.51  
 e-mail: cpi@catpumps.be www.catpumps.be

**CAT PUMPS DEUTSCHLAND GmbH**  
 Buchwiese 2, D-65510 Idstein, Germany  
 Phone 49 6126-9303 0 — Fax 49 6126-9303 33  
 e-mail: catpumps@t-online.de www.catpumps.de

**International Inquiries**  
 FAX (763) 785-4329  
 e-mail: intlsales@catpumps.com