

## ENGINEERING DRAWING PACKET

### MODEL PRO-8-1000-SP

DESIGN PRESSURE at 120 °F	1000 PSI	OPERATING pH RANGE	3-11
MINIMUM OPERATING TEMP.*	20°F	CLEANING pH RANGE (less than 30 minutes)	2-12
MAXIMUM OPERATING TEMP.	120°F	APPLICATION	TYP. SEAWATER
FACTORY TEST PRESSURE	1500 PSI	FEEDWATER TDS	<= 45,000 ppm Max.
BURST PRESSURE	6000 PSI		

### INTENDED USE

The **PROTEC PRO-8-1000-SP Pressure Vessel** is designed for continuous use as housing for membrane filtration elements to purify typical seawater waters at any positive pressure up to 1000 PSI. The **PRO-8-1000-SP** will accommodate any make of eight-inch nominal diameter spiral-wound element as well as many hollow fiber elements. The element interface hardware for the specified element is supplied with the vessel.

The Model **PRO-8-1000-SP** has been designed to meet the standards of the American Society of Mechanical Engineers (ASME), Boiler and Pressure Vessel Code, Section X. At an additional cost, vessels can be inspected during fabrication by an ASME Authorized Inspector and Code stamped.

The Model **PRO-8-1000-SP** must be installed, operated and maintained using good industrial practice and following the precautions listed in order to help assure safe operation and a long service life. Misuse, improper installation or operation may result in severe bodily harm or property damage and will void the vessel warranty. Therefore, review and follow the safeguards listed below **before** placing the vessels into service.

The filament-wound reinforced plastic shell of this vessel must be allowed to expand under pressure. Any undue restraint at the support points or piping connections can cause non-repairable leaks to develop in the shell. This vessel must not be subjected to excessive stress caused by bending moments acting at the side ports in the fiberglass shell.

The end closures of the vessel must be kept dry and free of corrosion at all times. Failure to do so may result in deterioration that can lead to catastrophic failure of the vessel heads.

When requested, Progressive Composite Technologies will assist the purchaser in determining the suitability of this standard vessel design for their operating environment. However, the final determination including the evaluation of the materials of construction for use in the specific corrosive environment shall be the responsibility of the purchaser. Alternate materials of construction may be available on special order.

*Before using this engineering packet for system design or vessel installation, please verify that it is the latest revision by consulting the factory. Specifications are subject to change without notice.*

### PRECAUTIONS

#### Follow all instructions.

Failure to take every precaution listed will void the vessel warranty and may result in vessel failure.

#### Mount shell using furnished hardware.

Following the recommended span(s) mount the vessel until the straps are "just snug". (less than one foot lb.)

#### Align the side ports with the manifold.

Center each vessel with the manifold and correct the causes of misalignment for each and every vessel.

#### Use flexible type groove-end pipe couplings.

Using Victaulic<sup>TM</sup> style 77 or equal fittings at each side port, allow a full .125 gap between each port /manifold connection

#### Maximize the connection flexibility.

Position the vessel and the piping to so that the vessel can grow in length and diameter under pressure without any undue restraint.  $\Delta DIA = 0.012$  in. (0.3mm) and  $\Delta L = 0.15$  in. (4mm) for a length code -8 vessel.

#### Provide overpressure protection.

Set the safety device at not more than 105% design pressure.

#### Inspect end closures regularly.

Replace damaged or deteriorated components and correct the cause of any corrosion.

#### Relieve system pressure before working on the vessel.

Working on vessels that are under pressure may result in bodily harm and/or property damage.

#### Never support other components with the vessel.

Hanging piping manifolds or supporting other components with the vessel may result in vessel damage.

#### Do not over tighten the Permeate Port connection.

Tightening the connection more than one turn past hand tight will damage the port.

#### Ensure that the Thrust Ring is installed downstream.

Operating without a thrust ring may cause membrane damage.

#### Double check end closure installation

Ensure that retaining ring is in place and fully seated.

#### Never operate the vessel in excess of its ratings.

This practice will void the vessel warranty, shorten vessel life and could lead to bodily harm or property damage.

#### Do not operate the vessel permeate port over 125 psi.

Permeate pressure in excess of 125 psi must be approved by the factory prior to operation.

#### Operate the vessel in only positive pressure applications.

This vessel is not designed for vacuum conditions.

#### Flush the vessel before system shut down.

Some feed waters may cause corrosion under static conditions. Flushing with non-corrosive permeate is recommended.

#### Operate the vessel within the recommended pH range.

The vessel is designed for continuous use at a pH of 3-11 and for intermittent cleaning (less than 30 min. at a pH of 2-12).

\*Please inform the factory when continuous operating temperature is less than 45°F.

## HEAD LOADING PROCEDURE

### Step 1 Inspect The Shell

Before installing the head, check the inside surface of the shell for any imperfections or foreign matter. Remove all foreign matter using a mild soap solution and rinse with clean water. To remove imperfections, lightly sand the surface of the vessel with 600-grit sandpaper and soapy water and then rinse with water can.

### Step 2 Head Seal And Shell Lubrication

Ensure that the head seal is covered with a thin layer of glycerin and is free from any dirt or dust contamination. Then lubricate the inside of the shell starting directly inboard of the retaining ring groove and up the energizing ramp into the vessel bore. Only a thin layer is required. Silicone lubricants can also be used; however, care should be taken to use as little as possible. Check with your membrane supplier before using these lubricants as they can foul membranes.

### Step 3 Install Head

Holding the head square to the axis of the shell, slowly push the head into the shell until the seal passes the retaining ring groove. As a resistance is felt, two hands may be required. Push the head into shell until the head clears the retaining ring groove.

### Step 4 Install Retaining Ring

Remove any moisture from the retaining groove before proceeding. Carefully place the end of the retaining ring into the groove on the shell. After the ring is started, slowly push the ring towards the groove. As the ring enters the groove, continue pushing as your hand slowly rotates counter-clockwise around the inside diameter of the shell. Be careful to prevent the ring from snapping against your finger as it enters the groove

### Step 5 Reconnect Permeate Port

Reconnect the permeate manifolding to the permeate port.

### Step 6 Pressurize System

Before starting the system, double check that each head has been correctly installed and that all piping connections are in place. After ensuring that all required precautions have been taken, start the system.

### Step 7 Check For Leaks

After system start up, verify that all connections are leak free. Fix any leaks at this time to prevent corrosion that may lead to component deterioration and possibly unsafe operation.

## HEAD REMOVAL PROCEDURE

### Step 1 Shut Down System

Shut down system and take all steps necessary to relieve system pressure from the vessel.

### Step 2 Disconnect Permeate Piping

Carefully disconnect the permeate piping from the permeate port. Set this piping in a secure place for re-assembly.

### Step 3 Check End Closure

Examine the end closure for any corrosion or damage. Remove any corrosion with a wire brush and flush away the deposits with clean water. Order replacement components as required.

### Step 4 Remove Retaining Ring

Pull the retaining ring out of the groove in the shell. After the ring is removed from the groove for ¼ turn, stop pulling. Finish removing the ring by running your finger behind the ring and carefully pulling the ring from groove. It is best to follow the ring in a clock-wise direction while removing to avoid stretching the ring.

### Step 5 Remove Head

While holding the permeate port with your hand, simply pull the head from the shell. In some instances it may be required to thread a connection onto the permeate port and gently rock the head up and down to release the head from the shell.

## SIDE PORT SEAL REPLACEMENT

While it is possible to replace the side port seal without removing the port, port removal is the best way to ensure that the seal gland is not damaged and to inspect/recondition the gland as required. Before this procedure is started, it is strongly recommended that a replacement retaining ring and a new port seal be purchased to ensure correct port installation.

### Step 1 Remove Retaining Ring

Carefully remove the metal retaining ring from the permeate port as to not damage the ring or the port.

### Step 2 Remove Side Port

Mark the port and the shell to indicate correct port location for installation. Rotate the vessel, until the port is in the 2 O'clock position. Place a soft towel into the vessel bore to prevent any possible damage. Using a rubber mallet, lightly tap on the port from the outside of the vessel while holding the port from inside the vessel. Continue to tap on the port until it is removed.

### Step 3 Inspect Port

Inspect inside the port for any corrosion and remove any deposits with a mild abrasive. Ports that have pitting or crevice corrosion should be replaced. Inspect the sealing area of the port for areas that may create sealing problems. Imperfections can be sanded with 600-grit sandpaper and soap solution. If any imperfections cannot be removed in this manner, port replacement is required.

### Step 4 Inspect Shell

Inspect the sealing area of the shell for areas that may create sealing problems. Imperfections can be lightly sanded with 600-grit sandpaper and a mild soap solution. If any imperfections cannot be removed in this manner the port may leak. If this is found to be the case, the vessel will require a factory technician to repair the damaged area. Contact the factory for further information.

### Step 5 Install The Port

Using the clocking marks from the port removal, install the port into the vessel wall by pushing it from the inside toward the outside of the vessel. Push the port into position until the snap ring groove clears the outside of the shell.

### Step 6 Install The New Retaining Ring

Carefully install the new retaining ring being very careful not to stretch it out of shape. Feed one end of the ring into the groove. Then walk the ring into the groove by pushing on the ring with a small tool such as a screwdriver until the ring is completely installed into the groove.

### Step 7 Lubricate The New Seal

Lubricate the new seal with a thin layer of glycerin. Silicone lubricants can also be used; however, use as little as possible. Check with your membrane supplier before using these lubricants as they can foul membranes.

### Step 8 Install The New Seal

With the tongue depressor, push the seal all the way down at two points across from each other. Then repeat the process in the opposite direction. The seal should now be installed at four corners. Carefully continue to push the seal into the gland by alternating sides until the entire seal is installed.

## HEAD REBUILDING

Prior to following this procedure, remove the head following the procedure listed.

### Step 1 Remove Adapter

Pull the adapter from the permeate port by slowly pulling on the adapter body.

### Step 2 Remove Permeate Port

Carefully remove the metal retaining ring from the permeate port as to not damage the ring or the port. A new retaining ring may be required to assemble the head. After the ring is removed, carefully slip the bearing plate off the permeate port and set it aside. Then simply pull the permeate port from the sealing plate.

### Step 3 Remove Seals

Remove the seal from the permeate port and set aside. Using a small tool, such as a screwdriver or a paper clip, remove the seal from the inside of the permeate port and set aside.

### Step 4 Clean All Components

Using a mild soap solution, clean each component, rinse with fresh water and then dry with compressed air or a lint free towel.

### Step 5 Inspect Components

Examine each component for corrosion or damage that may affect the performance of the vessel. Replace any components that have corrosion or visual damage. In addition, carefully inspect each seal for damage or wear. It is recommended to replace each seal at this time. Please be aware that seal condition may affect system performance.

### Step 6 Lubricate Seals

Using extreme care, coat each seal with a thin layer of glycerin. Only a thin layer is required. Silicone lubricants can also be used; however, care should be taken to use as little as possible. Check with your membrane supplier before using these lubricants as they can foul membranes.

### Step 7 Reassemble Head

Reversing the removal procedure, reassemble the head. Please note that a new permeate port retaining ring may be required to ensure correct component performance.

## PIPING RECOMMENDATIONS

PROTEC pressure vessels are the most durable side port vessel available today. Unlike vessels with less durable designs, connecting PROTEC side ported vessels to manifolding or to each other is easily done if some very basic rules are followed. These are as follows:

**Use two flexible Victaulic™ connections when manifold accuracy is questionable.**

The tolerance required for side-porting vessels should be a total per port of .030. For retrofitting side-porting vessels into older systems or when manifold tolerances can simply not be guaranteed, the two-connection method is the safest approach.

**Use a single flexible Victaulic™ connection when manifold accuracy is not a problem.** This is possible when manifold to vessel misalignment can be held to within .030 in any direction. However, it is important to note that these flexible connections allow angular but not lateral misalignment. Therefore, any misalignment must be kept to a minimum.

**Use intermediate Victaulic™ connections in the manifolds when required.** This practice allows more flexibility in the system resulting in easier to install manifolds.

**Center the vessel between the manifolds.** This is very basic but commonly overlooked. If the port on one end is directly aligned with the manifold and the opposite is .060 off, centering the vessel before tightening the straps allows each end to handle .030. Do this with each vessel.

**Allow one concentrate manifold to float.** In some systems, the manifold can be connected to the vessels and supported by the floor but allowed to float in the axially direction to provide room for vessel growth under pressure.

**Let the manifold span be longer than the vessel span.**

Remember that the vessel will grow in length under pressure. Setting the manifold span on the long side is another way to provide room for vessel growth under pressure.

**Check each connection for acceptable misalignment.**

By installing the Victaulic™ connection without the gasket and drawing the bolts snug, the connector should be able to rotate by hand. On some systems this test may not be practical. In these cases the Victaulic™ connections must be able to be tightened without the need of excessive force. Force would indicate a major misalignment that could damage the vessel.

When in doubt, contact the factory.

## MULTIPLE PORT RECOMMENDATIONS

Multiple port vessels are those specified by the user to have more than one high-pressure port per end. This feature allows vessels to be directly connected together allowing water to flow through one vessel into another. This piping method has become an acceptable way to provide superior system designs while reducing system costs.

While the thought of directly bolting vessels together is easily understood, there are several guidelines that must be followed in order to have a good long-term system design. These are as follows:

**Flow-balance the system.**

When supplying feed water from one side of the vessels, take the concentrate from the opposite side. This will prevent more water from flowing through the first vessel and starting the second and third. This practice will help equalize feed flow to each vessel.

**Minimize pressure drop.**

As water passes through each vessel, a pressure drop occurs. This will result in the last vessel in a connected pass receiving less pressure than the first. Increasing port size reduces this effect.

**Optimize the water velocity through the ports.**

The speed of the water through the ports should be kept within a reasonable range to ensure proper long-term performance (typically 5-15 ft. per sec.) Speeds that are too fast result in port erosion while speeds that are too slow will promote corrosion.

**Consider feeding from the center of a pass or from both ends.**

This practice may eliminate problems with velocities that are too high for proper system performance.

**Avoid the temptation to use smaller ports.**

Even though the thought of adding on an extra vessel with small ports sounds reasonable, it can result in a pressure drop problem.

**Take caution when using more than one port size.**

Changing ports sizes in a second or third pass requires careful evaluation of pressure drop that can affect system performance.

**Check with your membrane supplier.**

It is a good idea to let your membrane supplier evaluate the performance of your proposed system.

**Don't assume that we endorse the use of multiple ports for your system.**

Just because vessels can be ported together does not make them the best choice for your system. Progressive Composite Technologies is not responsible for the misapplication of the multiple port option.

**1000 PSI  
SIDE PORT**

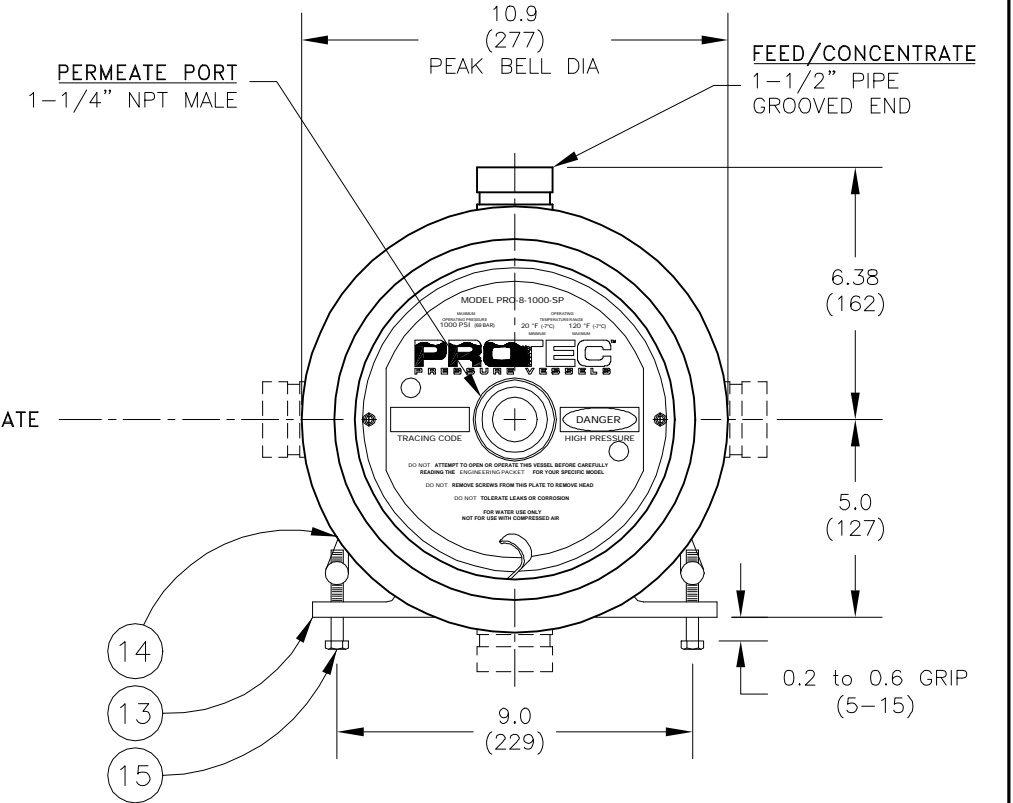
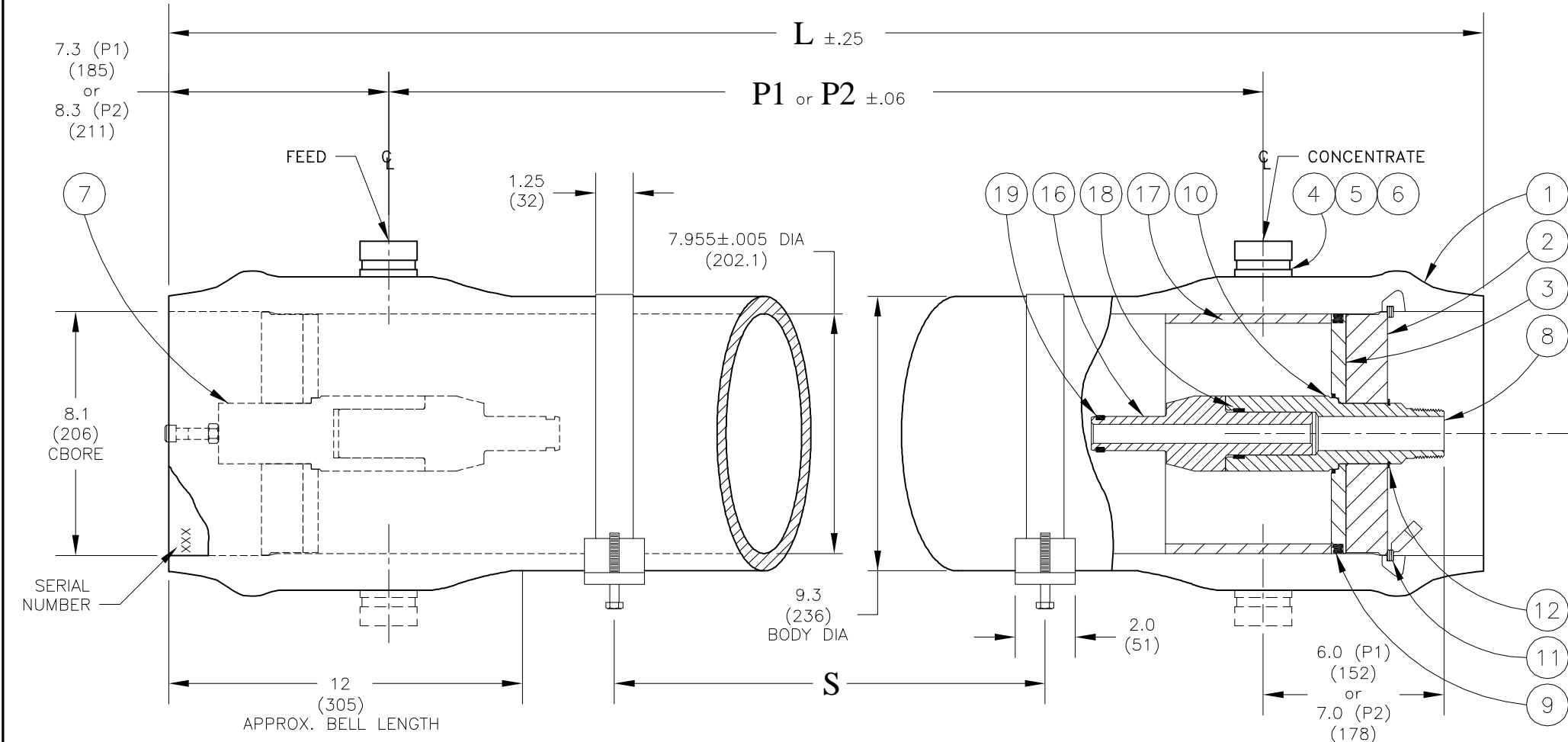

Shell Length Code	L inch (mm)	P1 Standard inch (mm)	P2 Optional inch (mm)	S Span in (mm)	Empty Weight lb (kg)
-1	61.6 (1565)	47 (1194)	45 (1143)	1 @ 28 (711)	133 (60)
-1.5	81.6 (2073)	67 (1702)	65 (1651)	1 @ 42 (1067)	157 (71)
-2	101.6 (2581)	87 (2210)	85 (2159)	1 @ 56 (1422)	180 (82)
-3	141.6 (3597)	127 (3226)	125 (3175)	1 @ 80 (2032)	228 (104)
-4	181.6 (4613)	167 (4242)	165 (4191)	2 @ 64 (1626)	275 (125)
-5	221.6 (5629)	207 (5258)	205 (5207)	2 @ 78 (1981)	322 (146)
-6	261.6 (6645)	247 (6274)	245 (6223)	2 @ 92 (2337)	370 (168)
-7	301.6 (7661)	287 (7290)	285 (7239)	2 @ 106 (2692)	417 (190)
-7.5	321.6 (8169)	307 (7798)	305 (7747)	2 @ 114 (2896)	441 (200)
-8	341.6 (8677)	327 (8306)	325 (8255)	2 @ 120 (3048)	464 (211)

ITEM	QTY	P/N	DESCRIPTION	MATERIAL
1	1	4080022	Shell	Filament Wound, Epoxy FRP
2	2	4080034	Bearing Plate	6061-T6 Aluminum, SB-221
3	2	4080064-1	Sealing Plate	PVC Thermoplastic
4	A/R	4080060-1	Feed/Concentrate Port	SST Super-Austenitic, 6% Mo ,SB-675
5	A/R	6121187	Retaining Ring, F/C Port	Stainless Steel, 316
6	A/R	6110225	Seal, F/C Port	Ethylene Propylene
7	1	2080004	Auto-Shim™ Assembly	PVC Thermoplastic
8	1	4080072-1	Permeate Port, Downstream	PVC Thermoplastic
9	2	6100442	Head Seal	Ethylene Propylene
10	2	6110229	Permeate Port Seal	Ethylene Propylene
11	2	4080083	Retaining Ring w/ Finger Pull	Stainless Steel, 316
12	2	6130200	Retaining Ring, Permeate Port	Stainless Steel, 300 Series
13	2*	4080039	Support Saddle	Polyurethane
14	2	4080040	Strap Assembly	Stainless Steel, 300 Series
15	4	6150001	Strap Screw	Stainless Steel, 300 Series
16	A/R	-	Adapter	Thermoplastic (Upstream Solid)
17	1	4080043	Thrust Ring	PVC Thermoplastic
18	2	6110221	Adapter Seal	Ethylene Propylene
19	A/R	-	PWT Seal	Ethylene Propylene

\*3 each with shell length -4 and longer

**NOTES:**  
DIMENSIONS IN INCHES (MM APPROX.)  
FOR REFERENCE ONLY, NOT TO BE USED FOR CONSTRUCTION UNLESS CERTIFIED  
CENTER VESSEL ON 2 OR 3 SUPPORTS AT SPAN(S) "S". 3 SUPPORTS REQUIRED FOR LENGTHS -4 AND OVER  
INCORRECT MANIFOLDING WILL CAUSE SEVERE LOCAL STRESS AROUND PORT AND MAY RESULT IN LEAKS AND PREMATURE FAILURE. TAKE EVERY PRECAUTION LISTED IN THIS PACKET.  
INTERNAL PERMEATE PRESSURE MUST NOT EXCEED 125 PSI.  
ASME SECTION X, RP CODE STAMP OPTIONAL  
SPECIFICATIONS SUBJECT TO CHANGE WITHOUT NOTICE



**PRO 8-1000-SP**

ENGR AP 7/6/01	ECO	REVISED 7/10/01	DRAWING 101005	REV A
QLTY BJ 7/9/01	2001-127			
MRKT DWE 7/9/01				

# PORT SPECIFICATION CHART

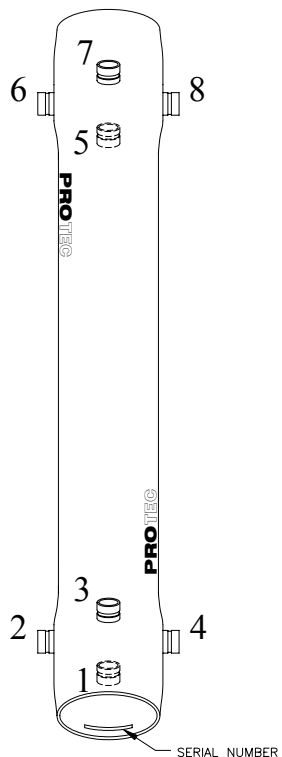

This chart is used to specify the location of the ports for each different vessel configuration in the system. Always use this chart to specify proper side port locations. Even though your system may use a standard port configuration, this chart allows us to place the logos in the correct location. If you have any questions, call the factory. Please use this chart as follows:

- 1) Determine proper port sizes using the multiple port guide.
- 2) Determine the proper port location for each vessel.
- 3) Starting at the serial number end, enter the location of the first port followed by the port size. Repeat this for each port on the serial number end.
- 4) Moving to the opposite end, enter the location of the first port followed by the port size. Repeat this for each port on this end.
- 5) Enter this information at the bottom of the ordering page for each vessel configuration.
- 6) Sign and date the ordering page before you send it in.

NOTE: Three ports per end maximum

Port Size Code	
D	1-1/2" Grooved End

Serial Number End

<input type="text"/>	<input type="text"/>	<input type="text"/>	<input type="text"/>	<input type="text"/>	<input type="text"/>
----------------------	----------------------	----------------------	----------------------	----------------------	----------------------

Opposite end

<input type="text"/>	<input type="text"/>	<input type="text"/>	<input type="text"/>	<input type="text"/>	<input type="text"/>
----------------------	----------------------	----------------------	----------------------	----------------------	----------------------

## EXAMPLE

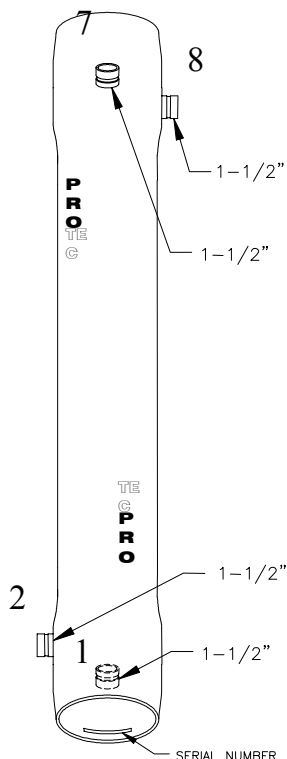

This example is provided to show you the proper way to specify you port locations. Please understand this example before filling out the ordering page. For questions concerning the use of this chart, please call the factory.

Serial Number End

1	D	2	D	<input type="text"/>	<input type="text"/>
---	---	---	---	----------------------	----------------------

Opposite end

7	D	8	D	<input type="text"/>	<input type="text"/>
---	---	---	---	----------------------	----------------------

**Calculated Pressure Drop into Vessel from Side Port**

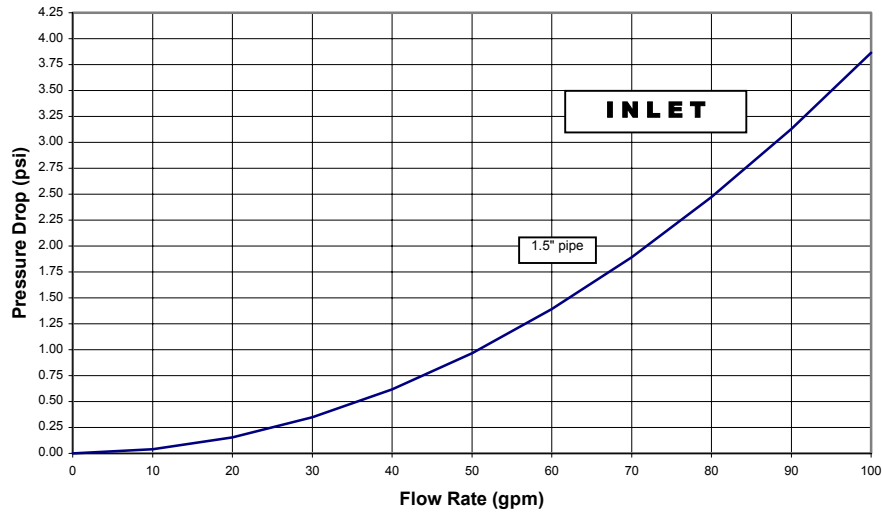

**Calculated Pressure Drop From Vessel into Side Port**

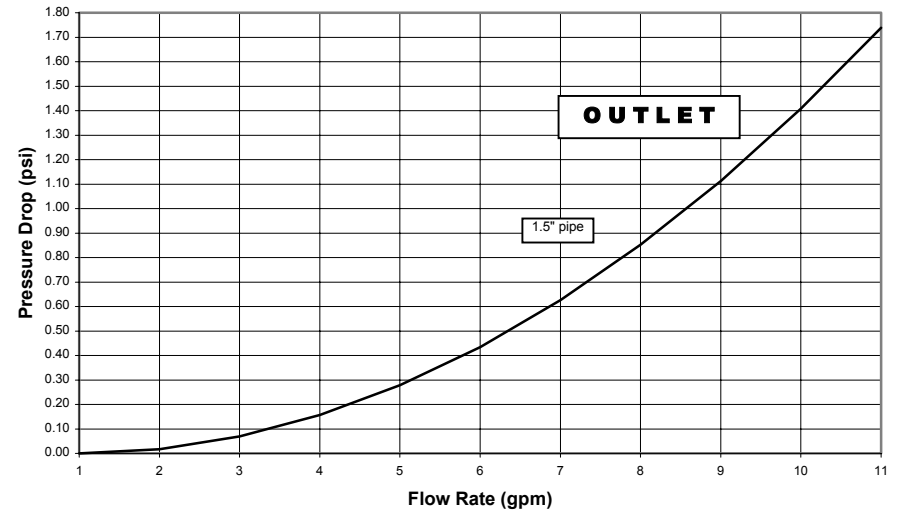

**MULTIPLE PORT DIAGRAM**

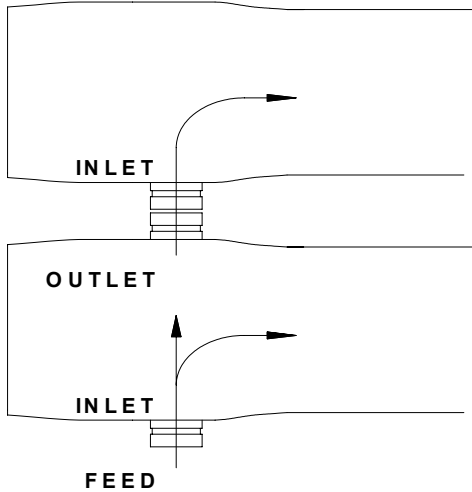

**CALCULATE THE VELOCITY AND PRESSURE DROP AT EACH PORT USING THE CALCULATED INFORMATION PROVIDED HERE**

**Velocity vs. Flow Rate in schedule 40 pipe**

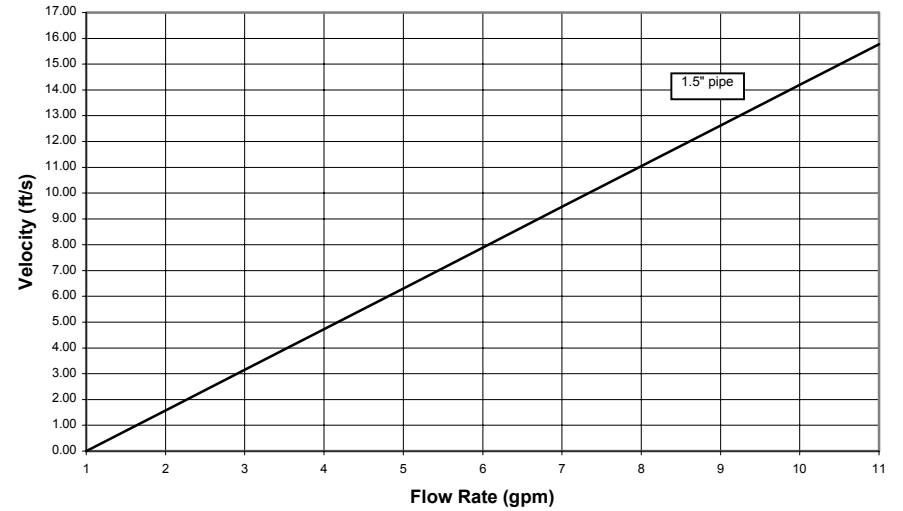

# ORDERING

Using the chart below, check the features you require and fax them with your purchase order to our customer service department. Fax 760-597-4830; phone 760-599-4800.

## LENGTH CODE

MODEL PRO 8-1000-SP  -1  -1.5  -2  -3  -4  -5  -6  -7  -7.5  -8

## EXTERIOR FINISH

- Standard - white high-gloss polyurethane coating over a smooth surface
- Option - other colors available for orders over 50 vessels. Call factory for details.

## CERTIFICATION

- Standard - certified by Progressive Composite Technologies, not code stamped.
- Option - ASME Code Section X, RP stamped certified by an ASME Authorized Inspector. Call factory for details.
- Option - ASME Code Section X, RP stamped per above and registered with the National Board. Call factory for details.

## MEMBRANE INFORMATION

Brand \_\_\_\_\_ Model \_\_\_\_\_ This information is required at the time of order.

## MATERIAL AND PORT OPTIONS

- Standard-all materials and port configurations per drawing in this packet. (P1 feed/conc. port dimensions only)**  
NOTE: The options listed below will increase the vessel price. Call factory for details.
- Option- **Standard without Auto-Shim.** Same permeate port on both ends.
- Option- **High Temperature package** for continuous operation over 120°F (P1 feed/conc. port dimensions only). Includes each permeate port, seal plate and adapter in PET material.
- Option- **Ultrapure package** for ultrapure operation.(P1 feed/conc. port dimensions only) Package includes: One 316L SS 1 1/2" permeate port with type 3A sanitary connection, one PET permeate port, two PET adapters (one standard and one solid).
- Option- **Sanitary package** for sanitary operation: Same as ultrapure operation but also includes two 316L SS feed / concentrate ports with 2" type 3A sanitary connections.

## CUSTOMER SPECIFIED VESSEL CONFIGURATION

Using the chart below, please specify the custom options you require.

### SEAL PLATE MATERIAL

- Standard -PVC Thermoplastic for applications up to 120°F
- Option -PET Thermoplastic for applications up to 176°F
- Option -316L Stainless Steel for applications up to 176°F

### FEED/CONCENTRATE PORT CONFIGURATIONS

- Standard -1 1/2" IPS pipe grooved ends with ports in-line (P1 lengths, 47" F/C length, see drawing for details)
- Option -1 1/2" IPS pipe grooved ends with ports in-line (P2 lengths, 45" F/C length, see drawing for details)
- Option -Multiple ports. Using the instructions in this packet, fill out your feed/concentrate port requirements in the space below. (P1 feed/conc. port dimensions only) List the port location first followed by the port size for each port.

Serial number end

Opposite end

### PERMEATE PORT CONFIGURATION

- Standard -1 1/4" NPT male threads
- Standard - without Auto-Shim 1 1/4" NPT male threads
- Option -1 1/4" IPS grooved end
- Option -1" NPT female threads

### PERMEATE PORT MATERIAL

- Standard -PVC Thermoplastic for applications up to 120°F
- Option -PET Thermoplastic for applications up to 176°F and high backpressure operation
- Option -316L Stainless Steel for applications up to 176°F and high backpressure operation

### HEAD SEAL

- Standard -EPDM Quad Ring

### ADAPTER MATERIAL

- Standard -PVC Thermoplastic for applications up to 120°F
- Option -PET Thermoplastic for applications up to 176°F and high backpressure operation

Vessel configuration approved by \_\_\_\_\_

Date / /