

Design Pressure = 600 PSI @ 120 °F
 Min. Design Temperature = 20 °F @ 600 PSI
 Hydrotest Pressure = 660 PSI

600 PSI
 SIDE PORT

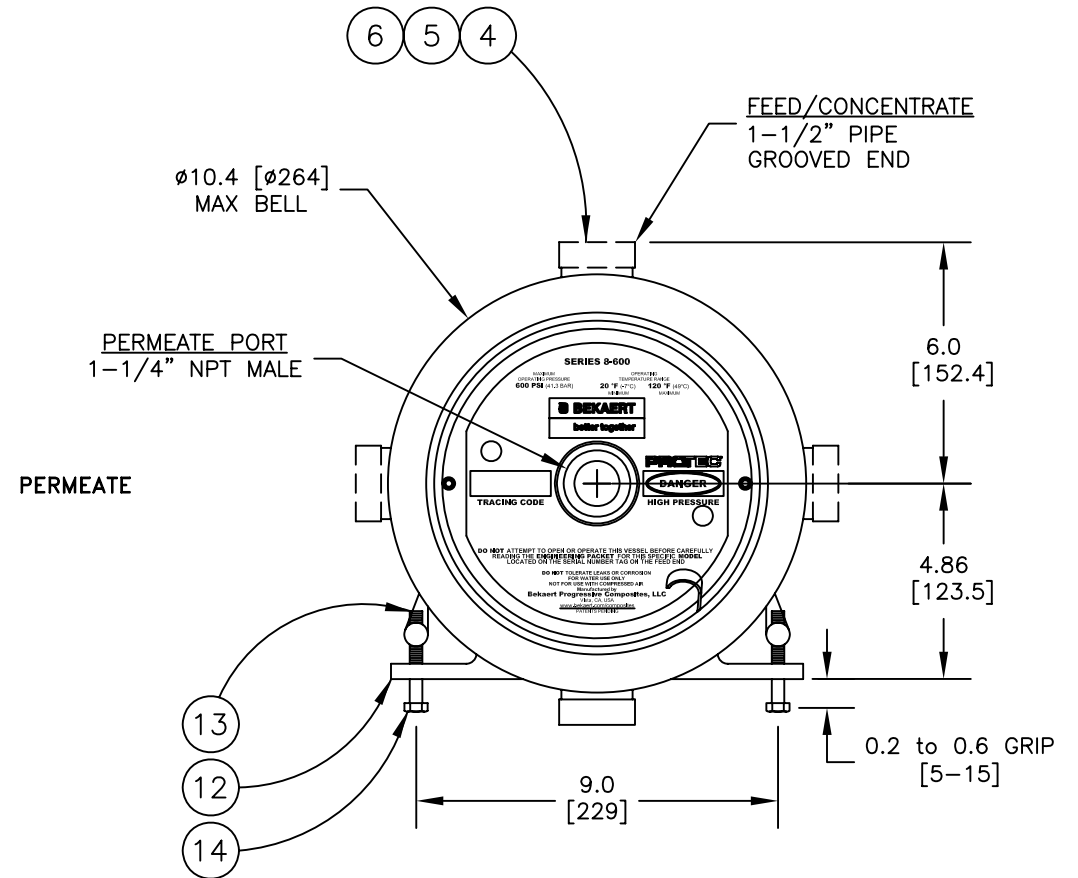

Shell Length Code	L inch (mm)	P1 Standard inch (mm)	P2 Optional inch (mm)	P3 Optional inch (mm)	S Span in (mm)	Empty Weight lb (kg)
-1	59 [1498.60]	47 [1193.80]	45 [1143.00]	46 [1168.40]	1 @ 28 [711.20]	87 [40]
-1.5	79 [2006.60]	67 [1701.80]	65 [1651.00]	66 [1676.40]	1 @ 42 [1066.80]	103 [47]
-2	99 [2514.60]	87 [2209.80]	85 [2159.00]	86 [2184.40]	1 @ 56 [1422.40]	118 [54]
-3	139 [3530.60]	127 [3225.80]	125 [3175.00]	126 [3200.40]	1 @ 80 [2032.00]	150 [68]
-4	179 [4546.60]	167 [4241.80]	165 [4191.00]	166 [4216.40]	2 @ 64 [1625.60]	181 [82]
-5	219 [5562.60]	207 [5257.80]	205 [5207.00]	206 [5232.40]	2 @ 78 [1981.20]	212 [96]
-6	259 [6578.60]	247 [6273.80]	245 [6223.00]	246 [6248.40]	2 @ 92 [2336.80]	243 [110]
-7	299 [7594.60]	287 [7289.80]	285 [7239.00]	286 [7264.40]	2 @ 106 [2692.40]	274 [125]
-7.5	319 [8102.60]	307 [7797.80]	305 [7747.00]	306 [7772.40]	2 @ 114 [2895.60]	290 [132]
-8	339 [8610.60]	327 [8305.80]	325 [8255.00]	326 [8280.40]	2 @ 120 [3048.00]	305 [139]

ITEM	QTY	P/N	DESCRIPTION	MATERIAL
1	1	4080021	Shell	Filament Wound, Epoxy FRP
2	2	4080032	Bearing Plate	6061-T6 Aluminum, SB-221, Anodized
3	2	4080177-2	Sealing Plate	Thermoplastic
4	2	4080257-1	Feed/Concentrate Port	Stainless Steel, 316L, SA-312
5	4	6121187	Retaining Ring, F/C Port	Stainless Steel, 316 Series
6	2	6110225-N	Seal, F/C Port	Ethylene Propylene
7	2	4080309	Permeate Port	Noryl GFN2
8	2	6100442MK	Head Seal	Ethylene Propylene
9	2	6110229-N	Permeate Port Seal	Ethylene Propylene
10	2	4080320	Retaining Ring w/ Finger Pull	Stainless Steel, 300 Series
11	2	6121200	Retaining Ring, Permeate Port	Stainless Steel, 300 Series
12	2*	4080174	Support Saddle	Thermoplastic Rubber
13	2	4080137	Strap Assembly	Stainless Steel, 300 Series
14	4	6150001	Strap Screw	Stainless Steel, 18-8
15	2	A/R	Adapter	PVC Thermoplastic
16	1	4080165-1	Thrust Cone	PVC Thermoplastic
17	2	6110326-N	Adapter Seal	Ethylene Propylene
18	A/R	A/R	PWT Seal	Ethylene Propylene

*3 each with shell lengths -4 and longer.

NOTES:
 DIMENSIONS IN INCHES (MM APPROX.)
 FOR REFERENCE ONLY, NOT FOR CONSTRUCTION UNLESS CERTIFIED
 SHIMMING OF THE SADDLES MAY BE REQUIRED
 CENTER VESSEL ON 2 SUPPORTS AT SPAN(S) "S". OPTIONAL 3 POINT SUPPORT QUOTED SEPARATELY FOR SHELL LENGTHS -4 AND LONGER.
 INCORRECT MANIFOLDING WILL CAUSE SEVERE LOCAL STRESS AROUND PORT AND MAY RESULT IN LEAKS AND PREMATURE FAILURE. TAKE EVERY PRECAUTION LISTED IN THIS PACKET.
 INTERNAL PERMEATE PRESSURE MUST NOT EXCEED 125 PSI.
 ASME SECTION X, RP CODE STAMP OPTIONAL
 SPECIFICATIONS SUBJECT TO CHANGE WITHOUT NOTICE



PRO 8-600-SP

ENGR EB 06/08/07	ECO 09016	REVISED 04/01/09	DRAWING 101004	REV P
QLTY				
MRKT				