

AMI[®] MEMBRANES

About AMI[®] Brand Membrane Elements

AMI Membrane Elements have earned the reputation of consistent quality. With hundreds of thousands of membranes in operation world-wide, AMI Membrane Elements are among the finest in the industry with performance comparable to most major brands.

Advantages of AMI Membranes

- Made in the USA in our ISO 9001:2008 Certified Facilities
- Offered in Reverse Osmosis, Ultrafiltration, Nanofiltration, Microfiltration, Seawater, and Special Membranes
- Available in a Large Range of Both Residential and Commercial Styles and Sizes
- NSF Certified in Select Models
- Backed by our Experienced Technical Support Staff
- High Quality for Consistent and Reliable Performance
- Competitive Prices



AMI Membranes Index

Membrane Type	page	Membrane Type	page
• Residential Thin Film RO Membranes	1-2	• CTA (Cellulose Triacetate) RO Membranes	1-10
• Commercial Tape Wrapped RO Membranes	1-3	• Replacement Membranes for Other Manufacturers	1-12
• Low Energy Commercial RO Membranes	1-4	• Nanofiltration Elements: NF5 & NF9	1-14
• Extra Low Energy Commercial RO Membranes	1-5	• Ultrafiltration Polyethersulfone (PES) Elements	1-15
• Fiberglass Wrapped Commercial RO Membranes	1-6	• Ultrafiltration Polyacrylonitrile (PAN) Elements	1-16
• Fiberglass Wrapped Low Energy RO Membranes	1-7	• Hollow Fiber Ultrafiltration Elements	1-17
• Fiberglass Wrapped Extra Low Energy Membranes	1-8	• Polyvinylidene Fluoride (PVDF) MF & UF Elements	1-18
• Seawater Desalination RO Membranes	1-9	• Microfiltration Polysulfone (PS) Elements	1-19

Private Label & Custom Membrane Elements are also available

Applied Membranes, Inc. can supply private label membranes in any membrane material in standard or proprietary styles in varying colors and dimensions based on your specifications. We can also provide encapsulated membrane elements.



Please contact us with your project information and we will be happy to work with you to fulfill your requirements.

Visit us on the web for our complete product line and in-depth technical information. www.appliedmembranes.com

APPLIED MEMBRANES INC.[®]

ISO 9001:2008 Certified Company

(760) 727-3711 • FX: (760) 727-4427
sales@appliedmembranes.com

AMI[®], APPLIED MEMBRANES INC.[®], APPLIED[®] ARE TRADEMARKS OF APPLIED MEMBRANES, INC. © 2012

Residential Tap Water TFC Membranes



M-T1512A12, M-T1512A18, M-T1812A24, M-T1812A36, M-T1812A50 M-T1812A75 & M-T1812A100 are NSF certified for material requirements only.
(M-T1812A150 is not NSF Certified)

Performance Specifications

Model No.	Permeate Flow Rate*		Size (Dia." x Length")	Minimum Salt Rejection (%)*	Stabilized Salt Rejection (%)*
	gpd	lpd			
M-T1512A12	12	45	1.50 x 12	96	98
M-T1512A18	18	68	1.50 x 12	96	98
M-T1812A24	24	91	1.75 x 12	96	98
M-T1812A36	36	136	1.75 x 12	96	98
M-T1812A50	50	190	1.75 x 12	96	98
M-T1812A75	75	284	1.75 x 12	96	98
M-T1812A100	100	379	1.75 x 12	96	98
M-T1812A150†	150	568	1.95 x 12	96	98

* Salt rejection and performance specifications shown are from internal test data.

Note: Performance specifications based on 500 ppm tap water, 50 psi (0.35 MPa) applied pressure, 77°F (25°C) feed water temperature, feed water pH 7-8 and 15% recovery. Element permeate flow may vary ± 20%.

Recommended Operating Conditions*

• Maximum operating pressure	125 psig (0.86 MPa)
• Maximum feed flow rate	2 gpm
• Maximum operating temperature	113°F (45°C)
• Maximum feed water turbidity	1 NTU
• Maximum feed water silt density index (15 min)	5
• Chlorine tolerance	<0.1 ppm
• Feed water pH range, Continuous Operation	2-11
• Feed water pH range, Short-Term Cleaning (30 minutes)	1-12
• Minimum brine flow to permeate flow ratio	4:1

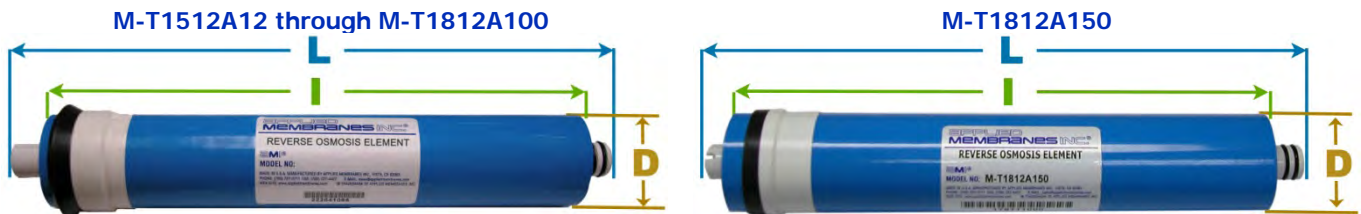

Membrane Element Dimensions

Model No.	L		I		D	
	inches	centimeters	inches	centimeters	inches	centimeters
M-T1512A(12-18)	11.75	29.8	10.0	25.4	1.50	3.8
M-T1812A(24-100)	11.75	29.8	10.0	25.4	1.75	4.4
M-T1812A150	11.75	29.8	10.0	25.4	1.95	5.0

† The 150 gpd membranes are designed for a tight fit in most standard housings. If the membrane fits loosely, you may need to wrap a few layers of tape near one end to make a tight fit. Tape Part # X-T160VWHI-2113. A loose fit will result in a higher permeate TDS.

Visit us on the web for our complete product line and in-depth technical information. www.appliedmembranes.com

APPLIED MEMBRANES INC.®

**ISO 9001:2008
Certified Company**

(760) 727-3711 • FX: (760) 727-4427
sales@appliedmembranes.com

AMI®, APPLIED MEMBRANES INC.®, APPLIED® ARE TRADEMARKS OF APPLIED MEMBRANES, INC. © 2012

Tape Wrapped RO Membranes for Commercial Applications

Performance Specifications

Model No.	Permeate Flow Rate		Size (Dia." × Length")	Single Element Recovery (%)	Minimum Salt Rejection (%)	Stabilized Salt Rejection (%)
	gpd	lpd				
M-T2013A	100	378	2.0 × 13	5	96	98
M-T2013AHF	130	492	2.0 × 13	5	96	98
M-T2026A	220	833	2.0 × 26	10	96	98
M-T2026AHF	280	1060	2.0 × 26	10	96	98
M-T2514A	200	757	2.5 × 14	5	98	99
M-T2514AHF	250	946	2.5 × 14	5	98	99
M-T2521A	325	1230	2.5 × 21	8	98	99
M-T2521AHF	405	1533	2.5 × 21	8	98	99
M-T2540A	850	3217	2.5 × 40	15	98	99
M-T2540AHF	1060	4012	2.5 × 40	15	98	99
M-T4014A	525	1987	4.0 × 14	5	98	99
M-T4014AHF	655	2479	4.0 × 14	5	98	99
M-T4021A	900	3407	4.0 × 21	8	98	99
M-T4021AHF	1125	4258	4.0 × 21	8	98	99
M-T4040A	2400	9084	4.0 × 40	15	98	99
M-T4040AHF	3000	11355	4.0 × 40	15	98	99

Note: Performance specifications based on 2,000 mg/l sodium chloride, 225 psi (1.6 MPa) applied pressure, 77°F (25°C) feed water temperature, pH 8 and the recovery listed in the table above. Element permeate flow may vary ± 20%.

Recommended Operating Conditions

• Maximum Operating Pressure	300 psig (2.1MPa)	• Maximum Feed Flow Rate	
• Maximum Operating Temperature	113°F (45°C)	○ 2" Dia. Elements	3 gpm
• Maximum Feed water Turbidity	1 NTU	○ 2.5" Dia. Elements	6 gpm
• Maximum Feed water SDI (15 min)	4	○ 4" Dia. Elements	17 gpm
• Chlorine Tolerance	0	• Feed water pH Range (Continuous)	2-11
• Maximum Pressure Drop:	13psig (0.9 bar)	• Feed water pH Range (Cleaning - 30 min.)	1-12

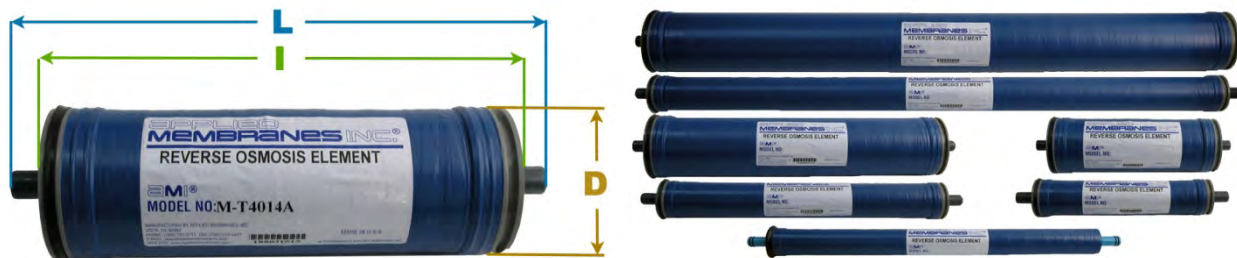

4 × 14 Shown for Dimensions, Actual Membrane Appearance Varies per Size.

Model No.	L		l		D	
	inches	centimeters	inches	centimeters	inches	centimeters
M-T2013A, AHF	13	33	10.64	27	1.8	4.6
M-T2026A, AHF	26	66	23.64	60	1.8	4.6
M-T2514A, AHF	14	35.6	11.62	30	2.5	6.4
M-T2521A, AHF	21	53.3	19	48	2.5	6.4
M-T2540A, AHF	40	101.6	38	96	2.5	6.4
M-T4014A, AHF	14	35.6	12	30	3.9	9.9
M-T4021A, AHF	21	53.3	19	48	3.9	9.9
M-T4040A, AHF	40	101.6	38	96	3.9	9.9

Visit us on the web for our complete product line and in-depth technical information. www.appliedmembranes.com

APPLIED MEMBRANES INC.[®]

ISO 9001:2008
Certified Company

(760) 727-3711 • FX: (760) 727-4427
sales@appliedmembranes.com

AMI[®], APPLIED MEMBRANES INC.[®], APPLIED[®] ARE TRADEMARKS OF APPLIED MEMBRANES, INC. © 2012

Low Energy Reverse Osmosis Membranes

AMI Low Energy Membrane Elements are specially designed to run at 150 psi. By using these elements instead of standard elements, you can significantly reduce your operating costs.

Performance Specifications

Model No.	Permeate Flow Rate		Size (Dia. " × Length ")	Single Element Recovery (%)	Minimum Salt Rejection (%)	Stabilized Salt Rejection (%)
	gpd	lpd				
M-T2026ALE	450	1703	2.0 × 26	10	98	99
M-T2514ALE	264	999	2.5 × 14	5	98	99
M-T2521ALE	450	1703	2.5 × 21	8	98	99
M-T2540ALE	1000	3785	2.5 × 40	15	98	99
M-T4014ALE	610	2309	4.0 × 14	5	98	99
M-T4021ALE	1148	4345	4.0 × 21	8	98	99
M-T4040ALE	2900	10976	4.0 × 40	15	98	99

Note: Performance specifications based on 2,000 mg/l sodium chloride, 150psi (1 MPa) applied pressure, 77°F (25°C) feed water temperature, pH 8 and the recovery listed in the table above. Element permeate flow may vary ± 20%.

Caution: Do not run these membranes at a pressure that will produce more than their rated product flow rate. This will lead to premature fouling of the membrane resulting in drop in permeate flow and higher TDS of the permeate.

Recommended Operating Conditions

• Maximum Operating Pressure	300 psig (2.1MPa)	• Maximum Feed Flow Rate	
• Maximum Operating Temperature	113°F (45°C)	○ 2" Dia. Elements	3 gpm
• Maximum Feed water Turbidity	1 NTU	○ 2.5" Dia. Elements	6 gpm
• Maximum Feed water SDI (15 min)	4	○ 4" Dia. Elements	17 gpm
• Chlorine Tolerance	0	• Feed water pH Range (Continuous)	2-11
• Maximum Pressure Drop:	13psig (0.9 bar)	• Feed water pH Range (Cleaning - 30 min.)	1-12



4 × 14 Shown for Dimensions, Actual Membrane Appearance Varies per Size.

Membrane Element Dimensions

Model No.	L		I		D	
	inches	centimeters	inches	centimeters	inches	centimeters
M-T2026ALE	26	66	23.64	60	1.8	4.6
M-T2514ALE	14	35.6	11.62	30	2.5	6.4
M-T2521ALE	21	53.3	19	48	2.5	6.4
M-T2540ALE	40	101.6	38	96	2.5	6.4
M-T4014ALE	14	35.6	12	30	3.9	9.9
M-T4021ALE	21	53.3	19	48	3.9	9.9
M-T4040ALE	40	101.6	38	96	3.9	9.9

Visit us on the web for our complete product line and in-depth technical information. www.appliedmembranes.com

APPLIED MEMBRANES INC.[®]

**ISO 9001:2008
Certified Company**

(760) 727-3711 • FX: (760) 727-4427
sales@appliedmembranes.com

AMI[®], APPLIED MEMBRANES INC.[®], APPLIED[®] ARE TRADEMARKS OF APPLIED MEMBRANES, INC. © 2012

Extra Low Energy Reverse Osmosis Membranes

AMI Extra Low Energy Membrane Elements are specially designed to run at 100 psi. By using these instead of standard elements, you can significantly reduce your operating costs.

Performance Specifications

Model No.	Permeate Flow Rate		Size (Dia." × Length")	Single Element Recovery (%)	Minimum Salt Rejection (%)*†	Stabilized Salt Rejection (%)*†
	gpd	lpd				
M-T2026AXLE	240	908	2.0 × 26	10	98	99
M-T2514AXLE	190	719	2.5 × 14	5	98	99
M-T2521AXLE	365	1382	2.5 × 21	8	98	99
M-T2540AXLE	850	3217	2.5 × 40	15	98	99
M-T4014AXLE	540	2044	4.0 × 14	5	98	99
M-T4021AXLE	1025	3880	4.0 × 21	8	98	99
M-T4040AXLE	2860	10825	4.0 × 40	15	98	99

Note: Performance specifications based on 500 mg/l sodium chloride, 100psi (0.7 MPa) applied pressure, 77°F (25°C) feed water temperature, pH 8 and the recovery listed in the table above. Element permeate flow may vary ± 20%.

Caution: Do not run these membranes at a pressure that will produce more than their rated product flow rate. This will lead to premature fouling of the membrane resulting in drop in permeate flow and higher TDS of the permeate.

Recommended Operating Conditions

• Maximum Operating Pressure	300 psig (2.1MPa)	• Maximum Feed Flow Rate	
• Maximum Operating Temperature	113°F (45°C)	○ 2" Dia. Elements	3 gpm
• Maximum Feed water Turbidity	1 NTU	○ 2.5" Dia. Elements	6 gpm
• Maximum Feed water SDI (15 min)	4	○ 4" Dia. Elements	17 gpm
• Chlorine Tolerance	0	• Feed water pH Range (Continuous)	2-11
• Maximum Pressure Drop:	13psig (0.9 bar)	• Feed water pH Range (Cleaning - 30 min.)	1-12



4 × 14 Shown for Dimensions, Actual Membrane Appearance Varies per Size.

Membrane Element Dimensions

Model No.	L		I		D	
	inches	centimeters	inches	centimeters	inches	centimeters
M-T2026AXLE	26	66	23.64	60	1.8	4.6
M-T2514XALE	14	35.6	11.62	30	2.5	6.4
M-T2521AXLE	21	53.3	19	48	2.5	6.4
M-T2540AXLE	40	101.6	38	96	2.5	6.4
M-T4014AXLE	14	35.6	12	30	3.9	9.9
M-T4021AXLE	21	53.3	19	48	3.9	9.9
M-T4040AXLE	40	101.6	38	96	3.9	9.9

Visit us on the web for our complete product line and in-depth technical information. www.appliedmembranes.com

APPLIED MEMBRANES INC.®

**ISO 9001:2008
Certified Company**

(760) 727-3711 • FX: (760) 727-4427
sales@appliedmembranes.com

AMI®, APPLIED MEMBRANES INC.®, APPLIED® ARE TRADEMARKS OF APPLIED MEMBRANES, INC. © 2012

Fiberglass Wrapped Brackish Water RO Membranes

Performance Specifications

Model No.	Permeate Flow Rate		Size (Dia. " × Length")	Single Element Recovery (%)	Minimum Salt Rejection (%)	Stabilized Salt Rejection (%)
	gpd	lpd				
M-B2514A	200	757	2.5 × 14	5	98	99
M-B2521A	325	1230	2.5 × 21	8	98	99
M-B2540A	850	3217	2.5 × 40	15	98	99
M-B2540AHF	1060	4012	2.5 × 40	15	98	99
M-B4014A	525	1987	4.0 × 14	5	98	99
M-B4014AHF	655	2479	4.0 × 14	5	98	99
M-B4021A	900	3407	4.0 × 21	8	98	99
M-B4021AHF	1125	4258	4.0 × 21	8	98	99
M-B4040A	2400	9084	4.0 × 40	15	98	99
M-B4040AHF	3000	11355	4.0 × 40	15	98	99

Note: Performance specifications based on 2,000 mg/l sodium chloride, 225 psi (1.6 MPa) applied pressure, 77°F (25°C) feed water temperature, pH 8 and the recovery listed in the table above. Element permeate flow may vary ± 20%.

Recommended Operating Conditions

• Maximum Operating Pressure	600 psig (4.1MPa)	• Maximum Feed Flow Rate	
• Maximum Operating Temperature	113°F (45°C)	○ 2" Dia. Elements	3 gpm
• Maximum Feed water Turbidity	1 NTU	○ 2.5" Dia. Elements	6 gpm
• Maximum Feed water SDI (15 min)	4	○ 4" Dia. Elements	17 gpm
• Chlorine Tolerance	0	• Feed water pH Range (Continuous)	2-11
• Maximum Pressure Drop:	15psig (1 bar)	• Feed water pH Range (Cleaning - 30 min.)	1-12

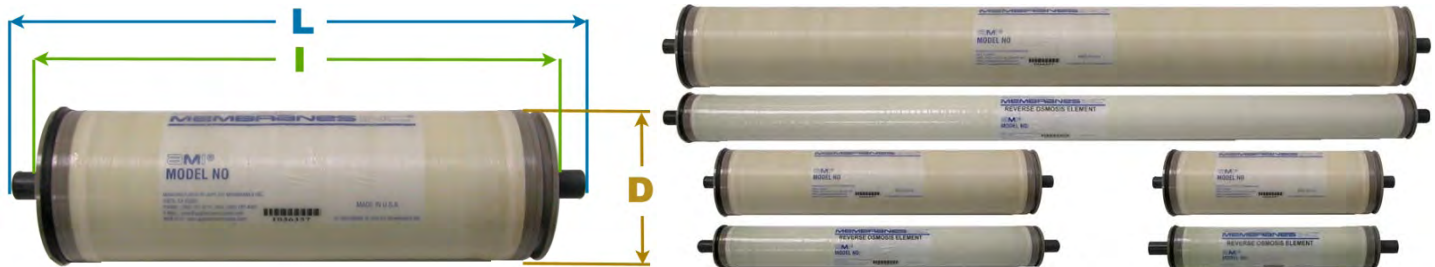

4 × 14 Shown for Dimensions, Actual Membrane Appearance Varies per Size.

Membrane Element Dimensions

Model No.	L		I		D	
	inches	centimeters	inches	centimeters	inches	centimeters
M-B2514A	14	35.6	11.62	30	2.5	6.4
M-B2521A	21	53.3	19	48	2.5	6.4
M-B2540A, AHF	40	101.6	38	96	2.5	6.4
M-B4014A	14	35.6	12	30	3.9	9.9
M-B4021A, AHF	21	53.3	19	48	3.9	9.9
M-B4040A, AHF	40	101.6	38	96	3.9	9.9

Visit us on the web for our complete product line and in-depth technical information. www.appliedmembranes.com

Fiberglass Wrapped Low Energy Membranes

AMI Low Energy Membrane Elements are specially designed to run at 150 psi. By using these instead of standard elements, you can significantly reduce your operating costs.

Performance Specifications

Model No.	Permeate Flow Rate		Size (Dia." × Length")	Single Element Recovery (%)	Minimum Salt Rejection (%)	Stabilized Salt Rejection (%)
	gpd	lpd				
M-B2514ALE	264	999	2.5 × 14	5	98	99
M-B2521ALE	450	1703	2.5 × 21	8	98	99
M-B2540ALE	850	3217	2.5 × 40	15	98	99
M-B4014ALE	610	2309	4.0 × 14	5	98	99
M-B4021ALE	1148	4345	4.0 × 21	8	98	99
M-B4040ALE	2700	10220	4.0 × 40	15	98	99

Note: Performance specifications based on 2,000 mg/l sodium chloride, 150 psi (1 MPa) applied pressure, 77°F (25°C) feed water temperature, pH 8 and the recovery listed in the table above. Element permeate flow may vary ± 20%.

Caution: Do not run these membranes at a pressure that will produce more than their rated product flow rate. This will lead to premature fouling of the membrane resulting in drop in permeate flow and higher TDS of the permeate.

Recommended Operating Conditions

• Maximum Operating Pressure	600 psig (4.1MPa)	• Maximum Feed Flow Rate	
• Maximum Operating Temperature	113°F (45°C)	○ 2" Dia. Elements	3 gpm
• Maximum Feed water Turbidity	1 NTU	○ 2.5" Dia. Elements	6 gpm
• Maximum Feed water SDI (15 min)	4	○ 4" Dia. Elements	17 gpm
• Chlorine Tolerance	0	• Feed water pH Range (Continuous)	2-11
• Maximum Pressure Drop:	15psig (1 bar)	• Feed water pH Range (Cleaning – 30 min.)	1-12

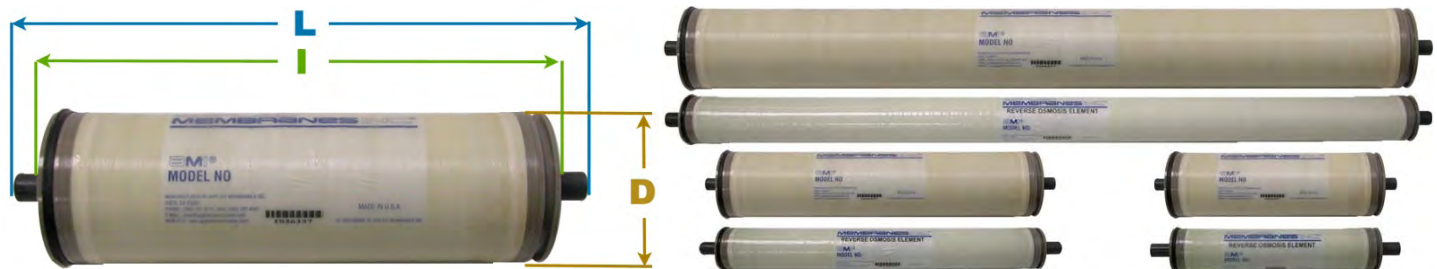

4 × 14 Shown for Dimensions, Actual Membrane Appearance Varies per Size.

Membrane Element Dimensions

Model No.	L		I		D	
	inches	centimeters	inches	centimeters	inches	centimeters
M-B2514ALE	14	35.6	11.62	30	2.5	6.4
M-B2521ALE	21	53.3	19	48	2.5	6.4
M-B2540ALE	40	101.6	38	96	2.5	6.4
M-B4014ALE	14	35.6	12	30	3.9	9.9
M-B4021ALE	21	53.3	19	48	3.9	9.9
M-B4040ALE	40	101.6	38	96	3.9	9.9

Visit us on the web for our complete product line and in-depth technical information. www.appliedmembranes.com

Fiberglass Wrapped Extra Low Energy Membranes

AMI Extra Low Energy Membrane Elements are specially designed to run at 100 psi. By using these instead of standard elements, you can significantly reduce your operating costs.

Performance Specifications

Model No.	Permeate Flow Rate		Size (Dia." × Length")	Single Element Recovery (%)	Minimum Salt Rejection (%)*†
	gpd	m ³ /day			
M-B2514AXLE	190	0.7	2.5 x 14	10	98
M-B2521AXLE	365	1.4	2.5 x 21	10	98
M-B2540AXLE	850	3.2	2.5 × 40	10	98
M-B4014AXLE	540	2.0	4.0 × 14	10	98
M-B4021AXLE	1,025	3.9	4.0 × 21	10	98
M-B4040AXLE	2,600	9.8	4.0 × 40	10	98

Note: Performance specifications based on 2,000 mg/l sodium chloride, 100 psi (1 MPa) applied pressure, 77°F (25°C) feed water temperature, pH 8 and the recovery listed in the table above. Element permeate flow may vary ± 20%.

Caution: Do not run these membranes at a pressure that will produce more than their rated product flow rate. This will lead to premature fouling of the membrane resulting in drop in permeate flow and higher TDS of the permeate.

Recommended Operating Conditions

• Maximum Operating Pressure	600 psig (4.1MPa)	• Maximum Feed Flow Rate	
• Maximum Operating Temperature	113°F (45°C)	○ 2" Dia. Elements	3 gpm
• Maximum Feed water Turbidity	1 NTU	○ 2.5" Dia. Elements	6 gpm
• Maximum Feed water SDI (15 min)	4	○ 4" Dia. Elements	17 gpm
• Chlorine Tolerance	0	• Feed water pH Range (Continuous)	2-11
• Maximum Pressure Drop:	15psig (1 bar)	• Feed water pH Range (Cleaning - 30 min.)	1-12



4 × 14 Shown for Dimensions, Actual Membrane Appearance Varies per Size.

Membrane Element Dimensions

Model No.	L		I		D	
	inches	centimeters	inches	centimeters	inches	centimeters
M-B2514AXLE	14	35.6	11.62	30	2.5	6.4
M-B2521AXLE	21	53.3	19	48	2.5	6.4
M-B2540AXLE	40	101.6	38	96	2.5	6.4
M-B4014ALE	14	35.6	12	30	3.9	9.9
M-B4021AXLE	21	53.3	19	48	3.9	9.9
M-B4040AXLE	40	101.6	38	96	3.9	9.9

Visit us on the web for our complete product line and in-depth technical information. www.appliedmembranes.com

APPLIED MEMBRANES INC.®

ISO 9001:2008
Certified Company

(760) 727-3711 • FX: (760) 727-4427
sales@appliedmembranes.com

AMI®, APPLIED MEMBRANES INC., APPLIED® ARE TRADEMARKS OF APPLIED MEMBRANES, INC. © 2012

Seawater Desalination RO Membrane Elements

AMI offers high rejection and high productivity seawater reverse osmosis membranes designed for marine applications. These seawater membranes are ideal for seawater desalination in shipboard applications, watermakers, land and sea based desalinators.

Performance Specifications

Model No.	Permeate Flow Rate		Size (Dia." × Length")	Single Element Recovery (%)	Minimum Salt Rejection (%)	Stabilized Salt Rejection (%)
	gpd	m ³ /day				
M-S2514A	150	0.57	2.5 × 14	2	99.2	99.4
M-S2521A	300	1.14	2.5 × 21	4	99.2	99.4
M-S2540A	700	2.65	2.5 × 40	8	99.2	99.4
M-S4021A	800	3.03	4.0 × 21	4	99.2	99.4
M-S4040A	1950	7.38	4.0 × 40	8	99.2	99.4

Note: Performance specifications based on 32,000 mg/l sodium chloride, 800 psi (5.5 MPa) applied pressure, 77°F (25°C) feed water temperature, pH 8 and the recovery listed in the table above. Element permeate flow may vary ± 20%.

Recommended Operating Conditions

• Maximum Operating Pressure	1,000 psig (6.9MPa)	• Maximum Feed Flow Rate	
• Maximum Operating Temperature	113°F (45°C)	○ 2.5" Dia. Elements	6 gpm
• Maximum Feed water SDI (15 min)	5	○ 4" Dia. Elements	16 gpm
• Chlorine Tolerance	0	• Feed water pH Range (Continuous)	2-11
• Maximum Pressure Drop:	15psig (1 bar)	• Feed water pH Range (Cleaning – 30 min.)	1-13



4 × 14 Shown for Dimensions, Actual Membrane Appearance Varies per Size.

Membrane Element Dimensions

Model No.	L		l		D	
	inches	centimeters	inches	centimeters	inches	centimeters
M-S2514A	14	35.6	11.62	30	2.5	6.4
M-S2521A	21	53.3	19	48	2.5	6.4
M-S2540A	40	101.6	38	96	2.5	6.4
M-S4021A	21	53.3	19	48	3.9	9.9
M-S4040A	40	101.6	38	96	3.9	9.9

Visit us on the web for our complete product line and in-depth technical information. www.appliedmembranes.com

APPLIED MEMBRANES INC.®

**ISO 9001:2008
Certified Company**

(760) 727-3711 • FX: (760) 727-4427
sales@appliedmembranes.com

AMI®, APPLIED MEMBRANES INC.®, APPLIED® ARE TRADEMARKS OF APPLIED MEMBRANES, INC. © 2012

Residential CTA (Cellulose Triacetate) RO Membranes

Performance Specifications

Model No.	Permeate Flow Rate		Size (Dia. " × Length")	Minimum Salt Rejection (%)
	gpd	lpd		
M-C1812A10	10	38	1.8 × 12	94
M-C1812A15	15	57	1.8 × 12	94
M-C1812A20	20	76	1.8 × 12	94

Note: Performance specifications based on 500 ppm tap water, 65 psi (0.47 MPa) applied pressure, 77°F (25°C) feed water temperature, feed water pH 7-8 and 15% recovery. Element permeate flow may vary ± 20%.

Recommended Operating Conditions

• Maximum operating pressure	125 psi (0.86 MPa)
• Maximum feed flow rate	2 gpm
• Maximum operating temperature	104°F (40°C)
• Maximum feed water turbidity	1 NTU
• Maximum feed water silt density index (15 min)	4
• Chlorine tolerance	0.3-0.5 ppm (1ppm maximum)
• Feed water pH range, Continuous Operation	4-6
• Feed water pH range, Short-Term Cleaning (30 minutes)	3-8
• Minimum brine flow to permeate flow ratio	4:1



Membrane Element Dimensions

Model No.	L		I		D	
	inches	centimeters	inches	centimeters	inches	centimeters
M-C1812A10	11.75	29.8	10.0	25.4	1.8	4.6
M-C1812A15	11.75	29.8	10.0	25.4	1.8	4.6
M-C1812A20	11.75	29.8	10.0	25.4	1.8	4.6

Visit us on the web for our complete product line and in-depth technical information. www.appliedmembranes.com

Commercial CTA (Cellulose Triacetate) RO Membranes

Performance Specifications

Model No.	Permeate Flow Rate		Size (Dia." × Length")	Single Element Recovery (%)	Minimum Salt Rejection (%)
	gpd	lpd			
M-C2514A	80	303	2.5 × 14	5	96
M-C2521A	117	443	2.5 × 21	8	96
M-C2540A	250	946	2.5 × 40	15	96
M-C4021A	350	1325	4.0 × 21	8	96
M-C4040A	1000	3785	4.0 × 40	15	96

Note: Performance specifications based on 500 ppm tap water, 225psi (1.6 MPa) applied pressure, 77°F (25°C) feed water temperature, pH 7-8 and the recovery listed in the table above. Element permeate flow may vary ± 20%.

Recommended Operating Conditions

• Maximum Operating Pressure	300 psig (2.1MPa)
• Maximum Operating Temperature	104°F (40°C)
• Maximum Feed water Turbidity	1 NTU
• Maximum Feed water Silt Density Index (15 min)	4
• Chlorine Tolerance	0.3-0.5 ppm (1 ppm maximum)
• Maximum Pressure Drop:	13psig (0.9 bar)
• Maximum Feed Flow Rate	
○ 2.5" Dia. Elements	6 gpm
○ 4" Dia. Elements	17 gpm
• Feed water pH Range (Continuous)	4-6
• Feed water pH Range (Cleaning - 30 min.)	3-8
• Minimum Brine Flow to Feed Flow Ratio	5:1

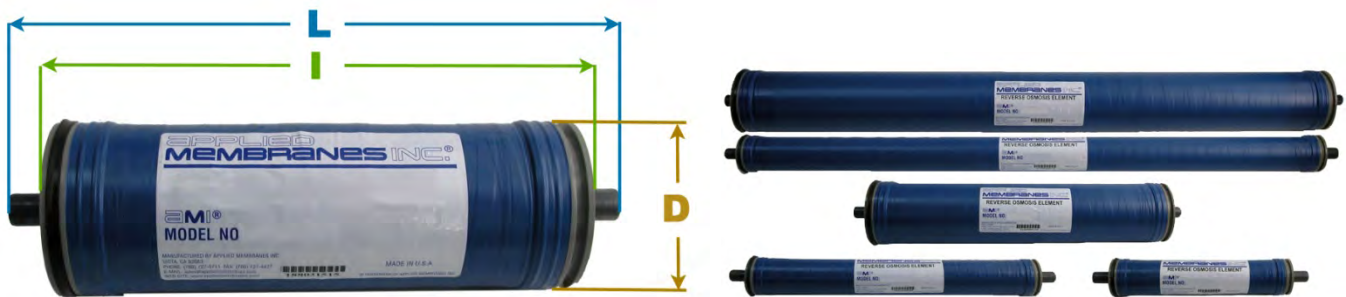

4 × 14 Shown for Dimensions, Actual Membrane Appearance Varies per Size.

Membrane Element Dimensions

Model No.	L		I		D	
	inches	centimeters	inches	centimeters	inches	centimeters
M-C2514A	14	35.6	11.62	30	2.5	6.4
M-C2521A	21	53.3	19	48	2.5	6.4
M-C2540A	40	101.6	38	96	2.5	6.4
M-C4021A	21	53.3	19	48	3.9	9.9
M-C4040A	40	101.6	38	96	3.9	9.9

Visit us on the web for our complete product line and in-depth technical information. www.appliedmembranes.com

Replacement Membranes for Other Manufacturers

CULLIGAN®: AMI Membrane Elements to Replace Culligan Brand Membranes

Model No.	Replaces Culligan Product	Type	Permeate Flow Rate		Minimum Salt Rejection (%)	Stabilized Salt Rejection (%)
			gpd	lpd		
M-T1812C24	TFC 24 – H8, H83	TF	24	90	96	98
M-T1812AC24	TFC 24 – AC Series	TF	24	90	96	98
M-T1812C36	TFC 36 – H8, H83	TF	36	136	96	98
M-T1812AC36	TFC 36 – AC Series	TF	36	136	96	98
M-T1812C50	TFC 50 – H8, H83	TF	50	190	96	98
M-T1812AC50	TFC 50 – AC Series	TF	50	190	96	98

H5, H8, H83 Style



AC- Series/ Aqua Clear Style



RAINSOFT®: AMI Membrane Elements to Replace Rainsoft Brand Membranes

Model No.	Replaces Rainsoft Product	Type	Permeate Flow Rate		Minimum Salt Rejection (%)	Stabilized Salt Rejection (%)
			gpd	lpd		
M-C1810R10	9564, 9590, 9593	CTA	10	38	94	94
M-T1810R12	9565, 9591, 9594, 9772, 9548	TF	15	45	96	98
M-T1810R24	9568, 9596	TF	24	90	96	98
M-T1810R50	18644, 18571, 12447, 21179, 17370, 9757, UF50T	TF	50	190	96	98
M-C1812A10	9744	CTA	10	38	94	94
M-T2514A	9792	TF	175	662	98	99



AMETEK/PENTEK®: AMI Membrane Elements to Replace Ametek Brand Membranes

Style (#)	Model No.	Replaces Ametek/US Filter & American Plumber Product	Type	Permeate Flow Rate	
				gpd	lpd
1	M-C1812A15	155414-01, RO-2127, CF1812T1738	CTA	15	57
2	M-T1812A24	155431-19, RO-3167, TFM-24-PL, WRO-31687	TF	24	90



Visit us on the web for our complete product line and in-depth technical information. www.appliedmembranes.com

Replacement Membranes for Other Manufacturers

AMETEK/PENTEK®: AMI Membrane Elements to Replace Ametek Brand Membranes

Model No.	Replaces Ametek Product	Type	Permeate Flow Rate		Size (Dia." × Length")	Minimum Salt Rejection (%)	Test Pressure (psi)
			gpd	lpd			
M-T3011AXLE	AMETEK 10	Thin Film	150	568	3.3 × 08	98	60
M-T3020A	AMETEK 20	Thin Film	800	3028	3.3 × 20	98	225

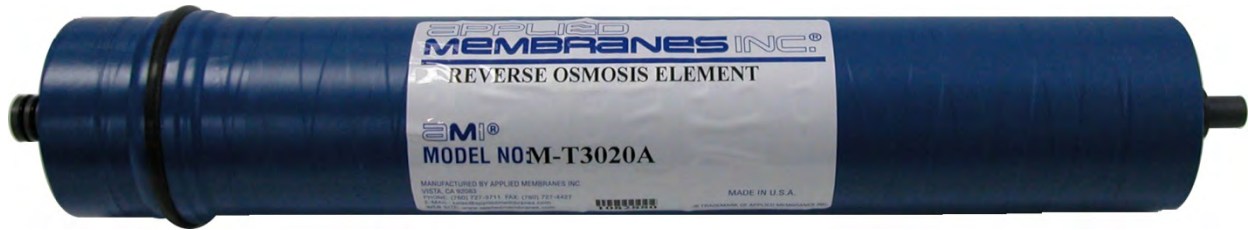

OSMONICS®/DESAL®: AMI Membrane Elements to Replace Osmonics/Desal Brand

Model No.	Replaces Osmonics Product	Replaces Desal Product	Flow Rate (gpd)	Size (Dia." × Length")	Minimum Salt Rejection (%)	Test Conditions
M-T2026A	112	SG2025TF	220	2.0 × 26	98	A
M-T2514A	--	SG2514TF, SH2514TF	175	2.5 × 14	98	A
M-T2521A	--	SG2521TF, SH2521TF	300	2.5 × 21	98	A
M-T2525A*	--	SG2525TF	500	2.5 × 25	98	A
M-T2525AHF*	--	SH2525TF	650	2.5 × 25	98	A
M-T2540A	217	AG2540TF, SG2540TF	660	2.5 × 40	98	A
M-C2540A	--	CE2540TF	250	2.5 × 40	96	B
M-B4040OSMO	411HR(PA)	--	2200	4.0 × 40	98	A
M-B4040AHF	414	AG4040FF	2800	4.0 × 40	98	A
M-T4040AHF	415	AG4040TF	2800	4.0 × 40	98	A
M-CB4040OSMO	411SR, 411HR	--	2100	4.0 × 40	96	C
M-CB4040AD	--	CE4040F, CD4040F	2100	4.0 × 40	96	C

* Sold without end adapters. End adapters AD-2425 and AD-2425PLG must be purchased separately.

TEST CONDITIONS: All 77°F, 25°C

	TDS, ppm	Press., psi	pH	% Recovery
A	2000	225	8	10
B	500	255	8	15
C	2000	425	5-6	15

Visit us on the web for our complete product line and in-depth technical information. www.appliedmembranes.com

APPLIED MEMBRANES INC.®

**ISO 9001:2008
Certified Company**

(760) 727-3711 • FX: (760) 727-4427
sales@appliedmembranes.com

AMI®, APPLIED MEMBRANES INC.®, APPLIED® ARE TRADEMARKS OF APPLIED MEMBRANES, INC. © 2012

Nanofiltration Membrane Elements: NF5 & NF9

Performance Specifications

Model No.	Permeate Flow Rate		Size (Dia." × Length")	Average Salt Rejection (%)	Average Hardness Rejection (%)
	gpd	lpd			
M-N1812A5	36	136	1.75 × 12	50	97 +
M-N2514A5	175	662	2.5 × 14	50	97 +
M-N2521A5	250	946	2.5 × 21	50	97 +
M-N2540A5	600	2271	2.5 × 40	50	97 +
M-N4014A5	450	1703	4.0 × 14	50	97 +
M-N4021A5	800	3028	4.0 × 21	50	97 +
M-N4040A5	2000	7570	4.0 × 40	50	97 +
M-N4040A5D*	2000	7570	4.0 × 40	50	97 +
M-N1812A9	36	136	1.75 × 12	90	97 +
M-N2514A9	175	662	2.5 × 14	90	97 +
M-N2521A9	250	946	2.5 × 21	90	97 +
M-N2540A9	600	2271	2.5 × 40	90	97 +
M-N4014A9	450	1703	4.0 × 14	90	97 +
M-N4021A9	800	3028	4.0 × 21	90	97 +
M-N4040A9	2000	7570	4.0 × 40	90	97 +
M-N4040A9D*	2000	7570	4.0 × 40	90	97 +

Note: Also available in FRP wrap (M-NB-)

* D= Flush Style. Replaces Desal 5.

30 mil spacer standard. For 43 mil spacer, add -43 at the end of the model number. Example: M-N2540A5-43.

Note: Performance specifications based on 2000 mg/l magnesium sulfate, 150 psi (1 MPa) applied pressure, 77°F (25°C) feed water temperature and 15% recovery. Element permeate flow may vary ± 20%. Permeate flow rates for feed streams other than water will vary.

Recommended Operating Conditions

• Maximum Operating Pressure	300 psig (2.1MPa)	• Maximum Feed Flow Rate	
• Maximum Operating Temperature	113°F (45°C)	○ 1.8" Dia. Elements	
• Maximum Feed water Turbidity	1 NTU	○ 2.5" Dia. Elements	6 gpm
• Maximum Feed water SDI (15 min)	4	○ 4" Dia. Elements	17 gpm
• Chlorine Tolerance (A3)	Up to 1	• Feed water pH Range (A3)	4-11
• Chlorine Tolerance (A9)	< 0.1	• Feed water pH Range (A9)	3-10
• Maximum Pressure Drop:	13 psig (0.9 bar)		

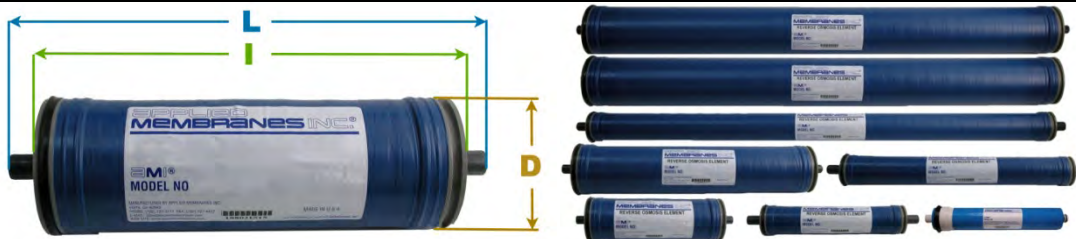

4 × 14 Shown for Dimensions, Actual Membrane Appearance Varies per Size.

Model No.	L		I		D	
	inches	centimeters	inches	centimeters	inches	centimeters
M-N1812A5, A9	11.75	29.8	10.0	25.4	1.75	4.4
M-N2514A5, A9	14	35.6	11.62	30	2.5	6.4
M-N2521A5, A9	21	53.3	19	48	2.5	6.4
M-N2540A5, A9	40	101.6	38	96	2.5	6.4
M-N4014A5, A9	14	35.6	12	30	3.9	9.9
M-N4021A5, A9	21	53.3	19	48	3.9	9.9
M-N4040A5, A9	40	101.6	38	96	3.9	9.9
M-N4040A5D, A9D	40	101.6	38	96	3.9	9.9

Visit us on the web for our complete product line and in-depth technical information. www.appliedmembranes.com

Ultrafiltration Membranes – Polyethersulfone (PES)

Performance Specifications

Model No.	Size (Dia." × Length")	Style	Outer Wrap	Molecular Weight Cut-Off (MWCO)
M-U1812PES	1.75 × 12	Standard	Tape Wrap	10,000
M-U2514PES	2.5 × 14	Standard	Tape Wrap	10,000
M-U2521PES	2.5 × 21	Standard	Tape Wrap	10,000
M-U2540PES	2.5 × 40	Standard	Tape Wrap	10,000
M-U4014PES	4.0 × 14	Standard	Tape Wrap	10,000
M-U4021PES	4.0 × 21	Standard	Tape Wrap	10,000
M-U4040PES	4.0 × 40	Standard	Tape Wrap	10,000
M-U4040PESD	4.0 × 40	Flush-Cut	Tape Wrap	10,000
M-UB4040PESD	4.0 × 40	Flush-Cut	FRP Wrap	10,000
M-UB8040PES	8.0 × 40	Flush-Cut, 46 mil	FRP Wrap	10,000

30 mil spacer standard for 2-4" Dia.. For 43 mil spacer, add -43 at the end of the model number. Example: M-U2540PES-43.

Note: An interconnector is provided with each 8" element, part no. PV-IN810.

Applications

- Absolute bacteria and virus removal from surface waters
- Beverage and liquid food processing and byproduct streams
- Applications requiring tolerance to solvents
- Treatment of oil, food, and pharmaceutical streams that require resistance to many esters and aromatics

Recommended Operating Conditions

• Maximum Operating Pressure	150psi (10 bar) at 77°F (25°C)
• Maximum Feed Flow Rate	
○ 1.8" Diameter Elements	2 gpm
○ 2.5 – 4" Diameter Elements	20 gpm
○ 8" Diameter Elements	80 gpm
• Maximum Operating Temperature	140°F (60°C) at 100 psi
• Chlorine Tolerance	5000 ppm days
• Feed water pH Range, Continuous Operation	2-11
• Feed water pH Range, Short-Term Cleaning (30 mins)	1-13

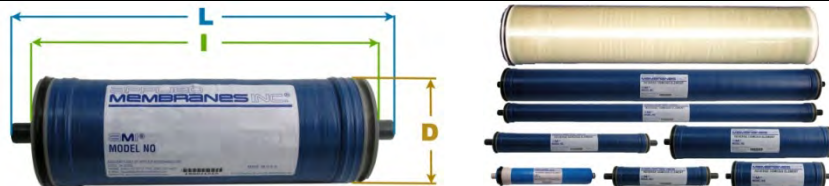

4 × 14 Shown for Dimensions, Actual Membrane Appearance Varies per Size.

Model No.	L		I		D	
	inches	centimeters	inches	centimeters	inches	centimeters
M-U1812PES	11.75	29.8	10.0	25.4	1.75	4.4
M-U2514PES	14	35.6	11.62	30	2.5	6.4
M-U2521PES	21	53.3	19	48	2.5	6.4
M-U2540PES	40	101.6	38	96	2.5	6.4
M-U4014PES	14	35.6	12	30	3.9	9.9
M-U4021PES	21	53.3	19	48	3.9	9.9
M-U4040PES	40	101.6	38	96	3.9	9.9
M-U(B)4040PESD	40	101.6	N/A	N/A	3.9	9.9
M-UB8040PES 1.125" Permeate Tube	40	101.6	N/A	N/A	7.9	20.1

Visit us on the web for our complete product line and in-depth technical information. www.appliedmembranes.com

Ultrafiltration Membranes – Polyacrylonitrile (PAN)

Performance Specifications

Model No.	Size (Dia. " × Length")	Style	Outer Wrap	Molecular Weight Cut-Off (MWCO)
M-U1812PAN	1.75 × 12	Standard	Tape Wrap	20,000
M-U2514PAN	2.5 × 14	Standard	Tape Wrap	20,000
M-U2521PAN	2.5 × 21	Standard	Tape Wrap	20,000
M-U2540PAN	2.5 × 40	Standard	Tape Wrap	20,000
M-U4014PAN	4.0 × 14	Standard	Tape Wrap	20,000
M-U4021PAN	4.0 × 21	Standard	Tape Wrap	20,000
M-U4040PAN	4.0 × 40	Standard	Tape Wrap	20,000
M-U4040PAND	4.0 × 40	Flush-Cut	Tape Wrap	20,000
M-UB4040PAND	4.0 × 40	Flush-Cut	FRP Wrap	20,000
M-UB8040PAN400	8.0 × 40	Flush-Cut, 46 mil	FRP Wrap	20,000

30 mil spacer standard for 2-4" Dia. For 43 mil spacer, add -43 at the end of the model number. Example: M-U2540PAN-43.

Note: An interconnector is provided with each 8" element, part no. PV-IN810.

Applications

- Fuel Oil/Water Separations
- Gray Water
- Black Water
- Paper/Pulp Wastewater Treatment
- Lignin and Textile Wastewater Cleanup
- Applications Requiring Tolerance to Many Solvents and Oils

Recommended Operating Conditions

• Maximum Operating Pressure	200 psig at 77°F (25°C)
• Maximum Feed Flow Rate	
○ 1.8" Diameter Elements	2 gpm
○ 2.5 – 4" Diameter Elements	20 gpm
○ 8" Diameter Elements	80 gpm
• Maximum Operating Temperature	122°F (50°C)
• Feed water pH Range, Continuous Operation	3-9

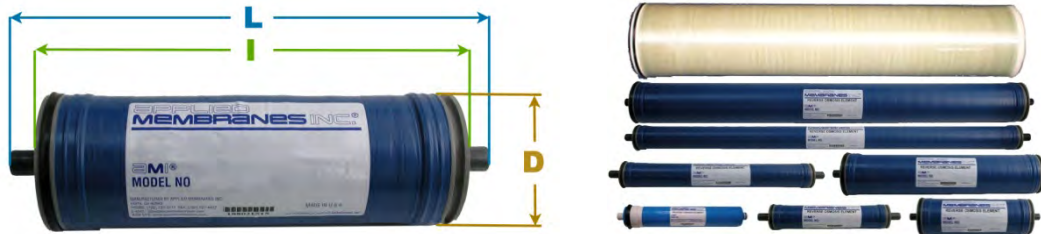

4 × 14 Shown for Dimensions, Actual Membrane Appearance Varies per Size.

Model No.	L		I		D	
	inches	centimeters	inches	centimeters	inches	centimeters
M-U1812PAN	11.75	29.8	10.0	25.4	1.75	4.4
M-U2514PAN	14	35.6	11.62	30	2.5	6.4
M-U2521PAN	21	53.3	19	48	2.5	6.4
M-U2540PAN	40	101.6	38	96	2.5	6.4
M-U4014PAN	14	35.6	12	30	3.9	9.9
M-U4021PAN	21	53.3	19	48	3.9	9.9
M-U4040PAN	40	101.6	38	96	3.9	9.9
M-U(B)4040PAND	40	101.6	N/A	N/A	3.9	9.9
M-UB8040PAN400 1.125" Permeate Tube	40	101.6	N/A	N/A	7.9	20.1

Visit us on the web for our complete product line and in-depth technical information. www.appliedmembranes.com

Hollow Fiber Ultrafiltration Membrane Elements

- Ideal for Pre-Treatment to Reverse Osmosis
- Can be used in Standard RO Housing with Filtrate Connector Kit (sold separately)
- Reliable Rejection of Microorganisms and Viruses
- Excellent Quality of Filtrate
- Easy Installation and Handling
- Housing, Filtrate Tube, Filtrate Connectors: PVC-U, White
- Maximum Trans-membrane Pressure[†]: 43.5 psi (3 bar)
- Temperature Range: 32°F to 104°F (0°C to 40°C)



Part Number	Size (Dia. x Length)	Membrane Type	Est. Flow [†] (gpd)		Membrane Area	
			Min	Max	sq. ft	m ²
M-U2514HF09	2.5" x 14"	Hollow Fiber 0.9	108	324	5.4	0.5
M-U2521HF09	2.5" x 21"	Hollow Fiber 0.9	220	660	11.0	1.0
M-U4021HF15	4" x 21"	Hollow Fiber 1.5	388	1,164	19.4	1.8
M-U4021HF09	4" x 21"	Hollow Fiber 0.9	540	1,620	27.0	2.5
M-U4040HF15	4" x 40"	Hollow Fiber 1.5	860	2,580	43.0	4.0
M-U4040HF09	4" x 40"	Hollow Fiber 0.9	1,300	3,900	65.0	6.0

† Design Notes:

1. Individual UF modules can be configured in parallel to provide increased system capacities.
2. The individual UF module flow ranges depend upon the source water quality and pretreatment. Consult with AMI for specific design flow rates for a specific application.
3. To avoid mechanical damage, do not subject the membrane to sudden temperature changes (>1°C/min) or water hammer

Filtrate Connectors for UF Membranes

Our hollow fiber UF membranes can be used in standard housings with the appropriate Filtrate Connector Kit as listed below. Please choose the appropriate connector kits below to adapt the hollow fiber elements to the vessel you will be using. (Two connectors are required per pressure vessel.)

Part Number	For HF UF Membrane	For Pressure Vessel
FC25	2.5" Diameter (M-&2514HF09 & M-U2521HF09)	Standard AMI/FilmTec Style 2.5" Dia. †
AD-40HF	4" Diameter (M-U4021HF* & M-U4040HF*)	Standard AMI/FilmTec Style 4" Dia. †
FC40	4" Diameter (M-U4021HF* & M-U4040HF*)	Special UF HF Vessel with ¾" Filtrate Ports [‡]

Pressure Vessels for Use with UF HF Membranes

For 4" Diameter elements, a specialty vessel with a larger filtrate port is available to reduce pressure drop. These are special order items and may not be in stock. †For standard vessels, please refer to section 2 of our catalog.

Part Number	Description
PV4021HF	PVC Pressure Vessel with ¾" Filtrate Port for 4" x 21" HF UF Membrane (Qty. 2 - FC40 Required)
PV4040HF	PVC Pressure Vessel with ¾" Filtrate Port for 4" x 40" HF UF Membrane (Qty. 2 - FC40 Required)

Membrane Element Dimensions

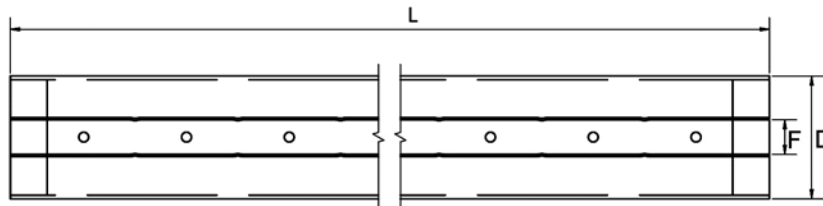

Model No.	Length (L)		Diameter (D)		Filtrate Connection ID (F)		Shipping Weight (Wet)
	inches	mm	inches	mm	inches	mm	
M-U2514HF09	11.8	300 ± 1.5	2.40	61	0.67	17.0	0.9 lbs
M-U2521HF09	18.7	475 ± 1.5	2.40	61	0.67	17.0	1.6 lbs
M-U4021HF15, 09	18.7	475 ± 1.5	3.94	100	1.12	28.4	5.0 lbs
M-U4040HF15, 09	37.8	960 ± 1.5	3.94	100	1.12	28.4	10 lbs

Visit us on the web for our complete product line and in-depth technical information. www.appliedmembranes.com

Polyvinylidene Fluoride (PVDF) MF & UF Elements

MICROFILTRATION (MF) PVDF – 0.2 Micron for Waste Water, Oily Water & Clarification.

Model No.	Size (Dia." × Length")	Style (From Below)	Outer Wrap	Dimensions (inches)			
				A	B	C	D
M-M1812VDF	1.75 × 12	1812	FRP Wrap	11.75	10.0	1.75	0.68
M-M2514VDF	2.5 × 14	I	FRP Wrap	14	11.62	2.5	0.75
M-M2521VDF	2.5 × 21	I	FRP Wrap	21	19	2.5	0.75
M-M2540VDF	2.5 × 40	I	FRP Wrap	40	38	2.5	0.75
M-M4014VDF	4.0 × 14	I	FRP Wrap	14	12	3.9	0.75
M-M4021VDF	4.0 × 21	I	FRP Wrap	21	19	3.9	0.75
M-M4040VDF	4.0 × 40	I	FRP Wrap	40	38	3.9	0.75

30 mil spacer standard for 2-4" Dia. For 43 mil spacer, add -43 at the end of the model number. Example: M-M2540VDF-43.

ULTRAFILTRATION (UF) PVDF – Electrocoat Elements

Model No.	Style (From Below)	Outer Wrap	Dimensions (inches)			
			A	B	C	D
M-U4028VDF-D400	II	FRP Wrap	28	N/A	4.0	0.62
M-U4033VDF-D400	II	FRP Wrap	33	N/A	4.0	0.62
M-U7640VDF-D400	II	FRP Wrap	40	N/A	7.4	1.285
M-U7638VDF-D400	III	FRP Wrap	38	33	7.4	1.66
M-U7641VDF-D400	III	FRP Wrap	40.5	33	7.4	1.66
M-U7648VDF-D400	III	FRP Wrap	47.5	40	7.4	1.66

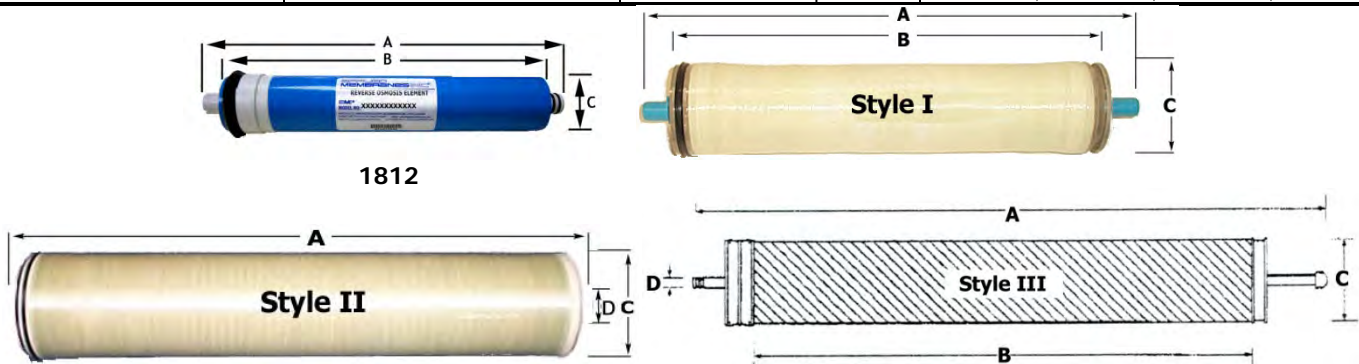

Recommended Operating Conditions

• Maximum Operating Pressure (MF)	200 psig at 77°F (25°C)
• Maximum Operating Pressure (UF)	50 psig
• Maximum Feed Flow Rate	
○ 4" Diameter Elements	20-25 gpm
○ 5.6" Diameter Elements	40-70 gpm
○ 7.6" Diameter Elements	50-110 gpm
• Feed water pH Range, Continuous Operation	2-12
• Feed water pH Range, Short-Term Cleaning	1-11

Visit us on the web for our complete product line and in-depth technical information. www.appliedmembranes.com

Microfiltration Elements – Polysulfone (PS)

Performance Specifications

Model No.	Size (Dia. " × Length")	Style	Outer Wrap	Molecular Weight Cut-Off (MWCO)
M-M1812PS20	1.75 × 12	Standard	Tape Wrap	20,000
M-M2514PS20	2.5 × 14	Standard	Tape Wrap	20,000
M-M2521PS20	2.5 × 21	Standard	Tape Wrap	20,000
M-M2540PS20	2.5 × 40	Standard	Tape Wrap	20,000
M-M4014PS20	4.0 × 14	Standard	Tape Wrap	20,000
M-M4021PS20	4.0 × 21	Standard	Tape Wrap	20,000
M-M4040PS20-D	4.0 × 40	Flush-Cut	Tape Wrap	20,000
M-MB4040PS20D	4.0 × 40	Flush-Cut	FRP Wrap	20,000
M-MB8040PS20	8.0 × 40	Flush-Cut, 46 mil	FRP Wrap	20,000

30 mil spacer standard for 2-4" Dia. For 43 mil spacer, add -43 at the end of the model number. Example: M-M2540PS20-43.
 Note: An interconnector is provided with each 8" element, part no. PV-IN810.

Applications

- Post-Treatment of ultrapure water
- Removal of suspended solids
- Process steam clarification, such as sugar solutions

Recommended Operating Conditions

• Maximum Feed Flow Rate	
○ 1.8" Diameter Elements	2 gpm
○ 2.5 – 4" Diameter Elements	20 gpm
○ 8" Diameter Elements	80 gpm
• Maximum Operating Temperature	122°F (50°C)
• Chlorine Tolerance	5,000+ ppm days
• Feed water pH Range, Continuous Operation	2-11
• Feed water pH Range, Short-Term Cleaning (30 min)	2-11.5
• Performance Challenge Material and Pressure	Polyethylene Glycol @ 30 psig

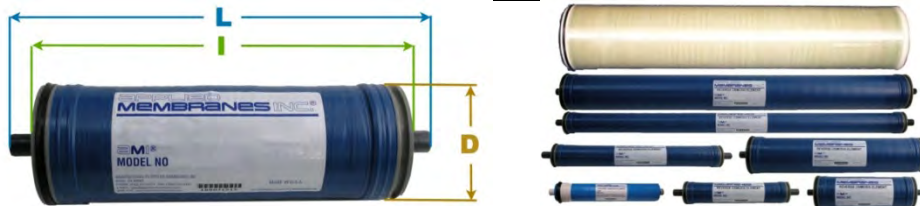

4 × 14 Shown for Dimensions, Actual Membrane Appearance Varies per Size.

Model No.	L		I		D	
	inches	centimeters	inches	centimeters	inches	centimeters
M-M1812PS20	11.75	29.8	10.0	25.4	1.75	4.4
M-M2514PS20	14	35.6	11.62	30	2.5	6.4
M-M2521PS20	21	53.3	19	48	2.5	6.4
M-M2540PS20	40	101.6	38	96	2.5	6.4
M-M4014PS20	14	35.6	12	30	3.9	9.9
M-M4021PS20	21	53.3	19	48	3.9	9.9
M-M4040PS20	40	101.6	38	96	3.9	9.9
M-M(B)4040PS20D	40	101.6	N/A	N/A	3.9	9.9
M-MB8040PS20 1.125" Permeate Tube	40	101.6	N/A	N/A	7.9	20.1

Visit us on the web for our complete product line and in-depth technical information. www.appliedmembranes.com

Residential Tap Water Thin Film Elements



Models TW30-1812-24, TW30-1812-36, TW30-1812-50 & TW30-1812-75 listed on this page are Tested and Certified to ANSI/NSF Standard 58

Performance Specifications

Model No.	Permeate Flow Rate†		Size (Dia. " × Length")	Applied Pressure (psi)	Stabilized Salt Rejection (%)*†
	gpd	lpd			
TW30-1812-24	24	91	1.8 × 12	50	98
TW30-1812-36	36	136	1.8 × 12	50	98
TW30-1812-50	50	190	1.8 × 12	50	98
TW30-1812-75	75	284	1.8 × 12	50	98
TW30-1812-100	100	379	1.8 × 12	50	90

- Permeate flow and salt rejection based on the following test conditions: 250 ppm softened tap water, 77°F (25°C), 15% recovery and the specified applied pressure.
- Minimum salt rejection is 96.0%.
- Permeate flows for individual elements may vary +/-20%.
- Product specifications may vary slightly as improvements are implemented.
- For ease of installation, element O-rings have been pre-lubricated with glycerin.



Operating Limits

• Membrane Type	Polyamide Thin-Film Composite
• Maximum Operating Temperature	113°F (45°C)
• Maximum Operating Pressure	150 psig (10 bar)
• Maximum Feed Flow Rate	2 gpm (7.6 lpm)
• Feed water pH Range, Continuous Operation ^a	2-11
• Feed water pH Range, Short-Term Cleaning (30 minutes) ^b	24-75 gpd: 1-12 • 100 gpd: 1-13
• Maximum Feed water Silt Density Index (SDI)	5
• Free Chlorine Tolerance ^c	<0.1 ppm

^a Maximum temperature for continuous operation above pH 10 is 95°F (35°C).

^b Refer to Cleaning Guidelines in specification sheet 609-23010.

^c Under certain conditions, the presence of free chlorine and other oxidizing agents will cause premature membrane failure. Since oxidation damage is not covered under warranty, FilmTec recommends removing residual free chlorine by pretreatment prior to membrane exposure.

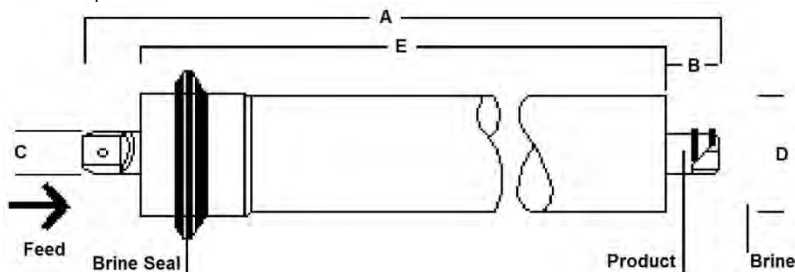

Model No.	A		B		C		D		E	
	inches	mm	inches	mm	inches	mm	inches	mm	inches	mm
TW30-1812 (24-75)	11.74	298	1.17	30	0.68	17	1.75	44.5	9.4	239
TW30-1812-100	11.74	298	0.87	22	0.68	17	1.75	44.5	10.0	254

Visit us on the web for our complete product line and in-depth technical information. www.appliedmembranes.com

APPLIED MEMBRANES INC.®

ISO 9001:2008
Certified Company

(760) 727-3711 • FX: (760) 727-4427
sales@appliedmembranes.com

AM, APPLIED MEMBRANES INC., APPLIED ARE TRADEMARKS OF APPLIED MEMBRANES, INC. © 2012

Tape Wrapped Elements for Commercial Applications

Standard Membrane Elements (TW30)

Model No.	Permeate Flow Rate		Size (Dia. " × Length")	Active Surface Area (Sq. Ft.)	Single Element Recovery (%)	Applied Pressure (psi)	Stabilized Salt Rejection (%)
	gpd	m ³ /d					
TW30-2026	220	0.83	2.0 × 26	7	10	225	99.5
TW30-2514	200	0.76	2.5 × 14	7	5	225	99.5
TW30-2521	325	1.23	2.5 × 21	13	8	225	99.5
TW30-2540	850	3.2	2.5 × 40	28	15	225	99.5
TW30-4014	525	1.99	4.0 × 14	20	5	225	99.5
TW30-4021	900	3.41	4.0 × 21	36	8	225	99.5
TW30-4040	2400	9.1	4.0 × 40	78	15	225	99.5
LC HR-4040	2900	11	4.0 × 40	94	15	225	99.5

Low and Extra Low Energy/Low Pressure Membrane Elements (LP & XLE)

Model No.	Permeate Flow Rate		Size (Dia. " × Length")	Active Surface Area (Sq. Ft.)	Single Element Recovery (%)	Applied Pressure (psi)	Stabilized Salt Rejection (%)
	gpd	m ³ /d					
LP-2540	1000	3.8	2.5 × 40	28	8	145	99.0
LP-4040	2900	11.0	4.0 × 40	78	8	145	99.2
XLE-2521	365	1.38	2.5 × 21	13	10	100	99.0
XLE-2540	850	3.2	2.5 × 40	28	15	100	99.0
XLE-4021	1025	3.88	4.0 × 21	36	5	100	99.0
XLE-4040	2600	9.8	4.0 × 40	87	15	100	99.0
LC LE-4040	2500	9.5	4.0 × 40	94	15	125	99.1

- Permeate flow and salt rejection based on the following test conditions: TW30 2,000 ppm NaCl feed stream XLE & LP 500 ppm NaCl feed stream, 77°F (25°C) and the pressure & recovery rates listed above.
- Permeate flows for individual elements may vary +/-20%. •For the purpose of improvement, specifications may be updated periodically.

Operating Limits

• Membrane Type: Polyamide Thin-Film Composite	• Maximum Feed Water Silt Density Index 5 SDI
• Maximum Operating Temperature 113°F (45°C)	• Free Chlorine Tolerance^c <0.1 ppm
• Feed water pH Range (Continuous)^a 2-11	• Maximum Pressure Drop 13 psig (0.9 bar)
• Feed water pH Range (Cleaning)^b 1-13	• Maximum Operating Pressure 600 psig (41 bar)

^a Maximum temperature for continuous operation above pH 10 is 95°F (35°C). ^b Refer to Cleaning Guidelines in spec sheet 609-23010.

^c Under certain conditions, the presence of free chlorine and other oxidizing agents will cause premature membrane failure. Since oxidation damage is not covered under warranty, FilmTec recommends removing residual free chlorine by pretreatment prior to membrane exposure.

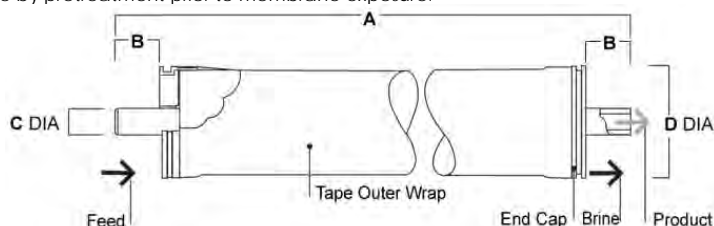

Model No.	Max. Feed Flow Rate		A		B		C		D	
	gpm	m ³ /hr	inches	mm	inches	mm	inches	mm	inches	mm
TW30-2026	5	1.1	26.0	660	1.18	30	0.68	17	1.8	46
TW30-2514	6	1.4	14.0	356	1.19	30	0.75	19	2.4	61
TW30-2521, XLE-2521	6	1.4	21.0	533	1.19	30	0.75	19	2.4	61
TW30-2540, XLE-2540, LP-2540	6	1.4	40.0	1016	1.19	30	0.75	19	2.4	61
TW30-4014	14	3.2	14.0	356	1.05	27	0.75	19	3.9	99
TW30-4021, XLE-4021	14	3.2	21.0	533	1.05	27	0.75	19	3.9	99
TW30-4040, XLE-4040, LP-4040	14	3.2	40.0	1016	1.05	27	0.75	19	3.9	99

Visit us on the web for our complete product line and in-depth technical information. www.appliedmembranes.com

APPLIED MEMBRANES INC.®

**ISO 9001:2008
Certified Company**

(760) 727-3711 • FX: (760) 727-4427
sales@appliedmembranes.com

AM, APPLIED MEMBRANES INC., APPLIED ARE TRADEMARKS OF APPLIED MEMBRANES, INC. © 2012

Fiberglass Elements for Commercial Systems

Fiberglass Wrapped RO Membrane Elements (BW30, LE)

Model No.	Permeate Flow Rate		Size (Dia. " × Length")	Active Surface Area (Sq. Ft.)	Feed Spacer Thickness (mil)	Applied Pressure (psi)	Stabilized Salt Rejection (%)
	gpd	m ³ /d					
BW30-2540	850	3.2	2.5 × 40	28	34	225	99.5
BW30-4040	2400	9.1	4 × 40	78	34	225	99.5
LE-4040	2500	9.5	4 × 40	78	28	150	99.0

- Permeate flow and salt rejection based on the following test conditions: 2,000 ppm NaCl, applied pressure as above, 77°F (25°C) and 15% recovery.
- Permeate flows for individual elements may vary +/-20%.
- For the purpose of improvement, specifications may be updated periodically.
- LE-4040 replaces BW30LE-4040.



Operating Limits

• Membrane Type	Polyamide Thin-Film Composite
• Maximum Operating Temperature	113°F (45°C)
• Maximum Operating Pressure	600 psig (41 bar)
• Maximum Pressure Drop	15 psig (1 bar)
• Maximum Feed Flow Rate	- 2.5 × 40 Elements: 6 gpm (1.4 m ³ /h) - 4 × 40 Elements: 16 gpm (3.6 m ³ /h)
• Feed water pH Range, Continuous Operation ^a	2-11
• Feed water pH Range, Short-Term Cleaning (30 minutes) ^b	1-13
• Maximum Feed water Silt Density Index (SDI)	5
• Free Chlorine Tolerance ^c	<0.1 ppm

^a Maximum temperature for continuous operation above pH 10 is 95°F (35°C).

^b Refer to Cleaning Guidelines in specification sheet 609-23010.

^c Under certain conditions, the presence of free chlorine and other oxidizing agents will cause premature membrane failure. Since oxidation damage is not covered under warranty, FilmTec recommends removing residual free chlorine by pretreatment prior to membrane exposure. Please refer to technical bulletin 609-22010 for more information.

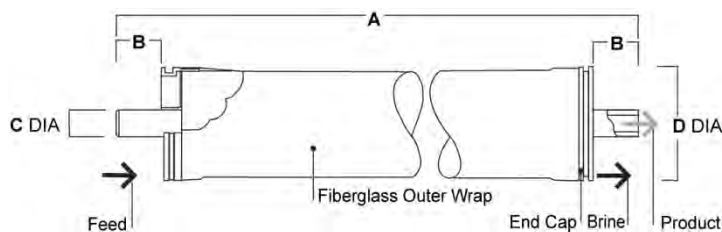

Model No.	A		B		C		D	
	inches	mm	inches	mm	inches	mm	inches	mm
BW30-2540	40.0	1016	1.19	30	0.75	19	2.4	61
BW30-4040, LE-4040	40.0	1016	1.05	27	0.75	19	3.9	99

Visit us on the web for our complete product line and in-depth technical information. www.appliedmembranes.com

APPLIED MEMBRANES INC.®

ISO 9001:2008 Certified Company

(760) 727-3711 • FX: (760) 727-4427
sales@appliedmembranes.com

AM, APPLIED MEMBRANES INC., APPLIED ARE TRADEMARKS OF APPLIED MEMBRANES, INC. © 2012

Brackish Water Elements for Industrial Applications

Brackish Water RO Membrane Elements

FILMTEC BW30 is the element of choice for systems requiring consistently high performance and the highest quality permeate. BW30-400 has more active area for a higher permeate flow; BW30-365 offers a wider feed spacer to maximize element life when treating difficult feed waters.

Model No.	Permeate Flow Rate		Size (Dia." x L")	Active Surface Area (Sq. Ft.)	Feed Spacer Thickness (mil)	Applied Pressure (psi)	Minimum Salt Rejection (%)	Stabilized Salt Rejection (%)
	gpd	m ³ /d						
BW30-365	9,500	36	8" x 40"	365	34	225	99.0	99.5
BW30-365-IG*	9,500	36	8" x 40"	365	34	225	99.0	99.5
BW30-400	10,500	40	8" x 40"	400	28	225	99.0	99.5
BW30-400-IG*	10,500	40	8" x 40"	400	28	225 </td <td>99.0</td> <td>99.5</td>	99.0	99.5

*Industrial Grade (IG) elements are designed for use in industrial water treatment applications. They maintain the same flow and rejection performance of the equivalent elements, but do not carry the ANSI standard 61 or KIWA certifications, offering a more cost effective option for industrial applications.

Low Energy and Extra Low Energy Brackish Water RO Membrane Elements

FilmTec Low Energy Brackish Water RO Elements are designed to deliver high quality water at 40-50% lower feed pressure to reduce energy and operating cost in municipal and industrial water applications.

Model No.	Permeate Flow Rate		Size (Dia." x L")	Active Surface Area (Sq. Ft.)	Feed Spacer Thickness (mil)	Applied Pressure (psi)	Minimum Salt Rejection (%)	Stabilized Salt Rejection (%)
	gpd	m ³ /d						
XLE-440	14,000	53	8" x 40"	440	28	125	98.0	99.0
LE-400	11,500	44	8" x 40"	400	28	150	99.0	99.3

Fouling Resistant RO Membrane Elements

FILMTEC fouling resistant elements are designed to purify water with high biological or organic fouling potential in systems with well-controlled pretreatment and offer superior fouling resistance and clean ability. BW30FR-400 has more active area for higher permeate flow; BW30FR-365 offers a wider feed spacer to maximize cleanability.

Model No.	Permeate Flow Rate		Size (Dia." x L")	Active Surface Area (Sq. Ft.)	Feed Spacer Thickness (mil)	Applied Pressure (psi)	Minimum Salt Rejection (%)	Stabilized Salt Rejection (%)
	gpd	m ³ /d						
BW30FR-400	10,500	40	8" x 40"	400	28	225	99.0	99.5
BW30FR-365	9,500	36	8" x 40"	365	34	225	99.0	99.5

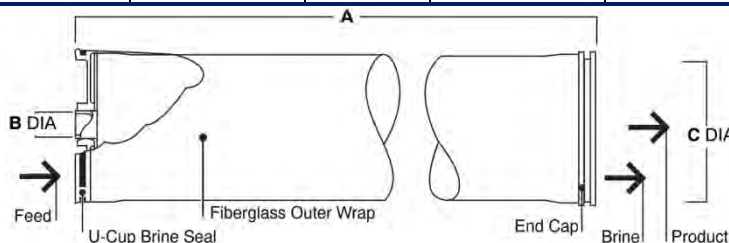

Model No.	A		B (ID)		C		Interconnector (one included with each element)
	inches	mm	inches	mm	inches	mm	
BW30FR-365, BW30FR-400, LE-400	40	1016	1.125	29	7.9	201	PV-IN810
XLE-440	40	1016	1.500	38	7.9	201	PV-IN810LE

Permeate flow rate and salt rejection shown on this page are based on the following test conditions: 2,000ppm NaCl (500 ppm for XLE), design pressures listed above, 77°F (25°C), and 15% recovery. Permeate flow rates for individual elements may vary +25/-15%. The above specifications are benchmark values. Please be sure to operate according to our system design guidelines. Please see individual products' specification sheet for operating limits and guidelines.

Visit us on the web for our complete product line and in-depth technical information. www.appliedmembranes.com

iLEC™ Interlocking Style Brackish Water Elements

A variety of FILMTEC elements are now available with iLEC interlocking end caps, an innovative element coupling technology that significantly enhances the performance of RO systems. Instead of using interconnectors to couple membranes end-to-end within a vessel, interlocking end caps twist directly together, reducing the number of sealing surfaces to a single axially compressed O-ring. The design reduces the potential for seal leakage, enabling sustained higher quality permeate, and reduces energy-consuming flow resistance, resulting in lower operating costs.

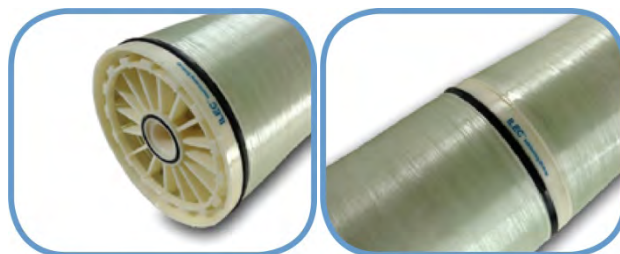

Interlocking Brackish Water Elements

FILMTEC BW30 is the element of choice for systems requiring consistently high performance and the highest quality permeate. BW30-440i has more active area for a higher permeate flow; BW30-400/34i offers a wider feed spacer to maximize element life when treating difficult feed waters. BW30HR-440i is a high productivity, high rejection RO membrane, with 99.7% Stabilized Salt Rejection, as well as stabilized rejection of 85% Boron, 99% NH₄⁺, 98.5% NO₃⁻, and 99.9% SiO₂.

Model No.	Permeate Flow Rate		Size (Dia. " × L")	Active Surface Area (Sq. Ft.)	Feed Spacer Thickness (mil)	Applied Pressure (psi)	Minimum Salt Rejection (%)	Stabilized Salt Rejection (%)
	gpd	m ³ /d						
BW30-400/34i	10,500	40	8" × 40"	400	34	225	99.0	99.5
BW30-440i	11,500	43	8" × 40"	440	28	225	99.0	99.5
BW30HR-440i	12,650	48	8" × 40"	440	28	225	99.4	99.7

Interlocking Low Energy Brackish Water Elements

FilmTec Low Energy Brackish Water RO Elements are designed to deliver high quality water at 40% lower feed pressure to reduce energy and operating cost in municipal and industrial water applications.

Model No.	Permeate Flow Rate		Size (Dia. " × L")	Active Surface Area (Sq. Ft.)	Feed Spacer Thickness (mil)	Applied Pressure (psi)	Minimum Salt Rejection (%)	Stabilized Salt Rejection (%)
	gpd	m ³ /d						
LE-440i	12,650	48	8" × 40"	440	28	150	99.0	99.3
HRLE-440i	12,650	48	8" × 40"	440	28	150	99.5	99.3

Interlocking Fouling Resistant Elements

FILMTEC fouling resistant elements are designed to purify water with high biological or organic fouling potential in systems with well-controlled pretreatment and offer superior fouling resistance and cleanability. BW30XFR-400/34i is a high productivity, high rejection RO membrane, with 99.65% Stabilized Salt Rejection, as well as stabilized rejection of 80% Boron, 98.8% NH₄⁺, 98.2% NO₃⁻, and 99.8% SiO₂.

Model No.	Permeate Flow Rate		Size (Dia. " × L")	Active Surface Area (Sq. Ft.)	Feed Spacer Thickness (mil)	Applied Pressure (psi)	Minimum Salt Rejection (%)	Stabilized Salt Rejection (%)
	gpd	m ³ /d						
BW30XFR-400/34i	11,500	44	8" × 40"	400	34	225	99.4	99.65
BW30FR-400/34i	10,500	40	8" × 40"	400	34	225	99.0	99.50
XFRLE-400/34 i	11,500	44	8" × 40"	400	34	225	99.4	99.2

Permeate flow rate and salt rejection shown on this page are based on the following test conditions: 2,000ppm NaCl, design pressures listed above, 77°F (25°C), and 15% recovery. Permeate flow rates for individual elements may vary +25/-15%. The above specifications are benchmark values. Please be sure to operate according to our system design guidelines. See product specifications sheets for operating limits and guidelines.

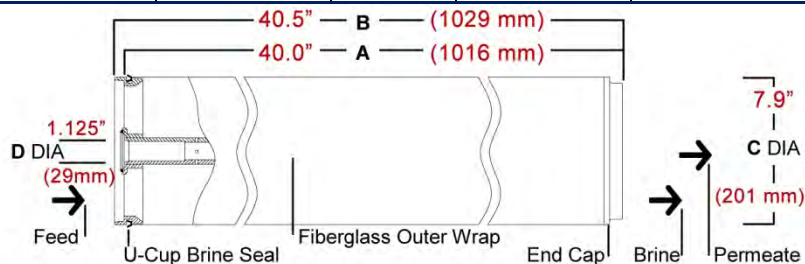

Visit us on the web for our complete product line and in-depth technical information. www.appliedmembranes.com

APPLIED MEMBRANES INC.®

ISO 9001:2008 Certified Company

(760) 727-3711 • FX: (760) 727-4427
sales@appliedmembranes.com

AM, APPLIED MEMBRANES INC., APPLIED ARE TRADEMARKS OF APPLIED MEMBRANES, INC. © 2012

Seawater RO Elements for Marine Systems

Designed to convert Seawater to Drinking Water in land and sea-based desalinators, the improved FILMTEC seawater reverse osmosis elements offer the highest productivity while maintaining excellent salt rejection in seawater desalination systems. FILMTEC seawater RO Elements can be used in water makers for seawater desalination in shipboard applications.



Performance Specifications

Model No.	Permeate Flow Rate		Size (Dia." x Length")	Active Surface Area (Sq. Ft.)	Single Element Recovery (%)	Applied Pressure (psi)	Stabilized Salt Rejection (%)
	gpd	m ³ /d					
SW30-2514	150	0.6	2.5" x 14"	6.5	2	800	99.4
SW30-2521	300	1.1	2.5" x 21"	13	4	800	99.4
SW30-2540	700	2.6	2.5" x 40"	29	8	800	99.4
SW30-4021	800	3.0	4.0" x 21"	33	4	800	99.4
SW30-4040	1,950	7.4	4.0" x 40"	80	8	800	99.4

Model No.	Permeate Flow Rate		Size (Dia." x Length")	Active Surface Area (Sq. Ft.)	Single Ele. Rec. (%)	Applied Pressure (psi)	Salt Rejection (%)		Stabilized Boron Rej. (%)
	gpd	m ³ /d					Stabilized	Min.	
SW30HRLE-4040	1,600	6.1	4.0" x 40"	85	8	800	99.7	99.6	91.0

Note: SW30HRLE-4040 RO Element is a four inch diameter version of SW30HRLE-400 and may also be used as a pilot element to demonstrate performance for the design of larger systems.

Permeate flow and salt rejection based on the following test conditions: 32,000 ppm NaCl feed stream (5ppm Boron, SW30HRLE), 77°F (25°C) and the pressure & recovery rates listed above. Permeate flows for individual elements may vary +/-20%.

For the purpose of improvement, specifications may be updated periodically.

Operating Limits

• Membrane Type:	Polyamide Thin-Film Composite	• Maximum Feed Water Silt Density Index	5 SDI
• Maximum Operating Temperature	113°F (45°C)	• Free Chlorine Tolerance ^c	<0.1 ppm
• Feed water pH Range (Continuous) ^a	2-11	• Maximum Pressure Drop	15 psig (1 bar)
• Feed water pH Range (Cleaning) ^b	1-13	• Maximum Operating Pressure	1,000 psig (69 bar) (SW30HRLE: 1,200 psig)

^a Maximum temperature for continuous operation above pH 10 is 95°F (35°C). ^b Refer to Cleaning Guidelines in spec sheet 609-23010.

^c Under certain conditions, the presence of free chlorine and other oxidizing agents will cause premature membrane failure. Since oxidation damage is not covered under warranty, FilmTec recommends removing residual free chlorine by pretreatment prior to membrane exposure. Please see individual products' specification sheet for operating limits and guidelines

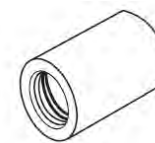
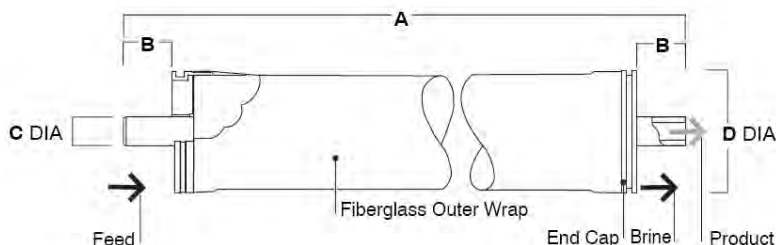

FilmTec sells coupler part number 89055 for use in multiple element housings. Each coupler includes two 2-210 EPR O-rings, FilmTec part number 89255.

Model No.	Max. Feed Flow Rate		A		B		C		D	
	gpm	m ³ /hr	inches	mm	inches	mm	inches	mm	inches	mm
SW30-2514	6	1.4	14.0	356	1.19	30	0.75	19	2.4	61
SW30-2521	6	1.4	21.0	533	1.19	30	0.75	19	2.4	61
SW30-2540	6	1.4	40.0	1016	1.19	30	0.75	19	2.4	61
SW30-4021	14	3.2	21.0	533	1.05	27	0.75	19	3.9	99
SW30-4040, SW30HRLE-4040	14	3.2	40.0	1016	1.05	27	0.75	19	3.9	99

Visit us on the web for our complete product line and in-depth technical information. www.appliedmembranes.com

APPLIED MEMBRANES INC.®

ISO 9001:2008 Certified Company

(760) 727-3711 • FX: (760) 727-4427
sales@appliedmembranes.com

AM, APPLIED MEMBRANES INC., APPLIED ARE TRADEMARKS OF APPLIED MEMBRANES, INC. © 2012

Seawater RO Elements for Industrial Systems

Performance Specifications

- SW30HR-380 delivers high boron rejection.
- SW30HRLE-400 offers highest capacity available.
- SW30-8040 & SW30-6040 seawater desalination reverse osmosis elements for marine applications.

Model No.	Permeate Flow Rate		Size (Dia." x Length")	Active Surface Area (Sq. Ft.)	Feed Spacer Thickness (mil)	Applied Pressure (psi)	Salt Rejection (%)		Stabilized Boron Rej. (%)
	gpd	m ³ /d					Stabilized	Min.	
SW30HR-380	6,000	23	8" x 40"	380	28	800	99.70	99.6	92.0
SW30HRLE-400	7,500	28	8" x 40"	400	28	800	99.75	99.6	91.0
SW30-6040	2,100	8	6" x 40"	N/A	34	800	99.40	99.0	N/A

The above values are normalized to the following test conditions: 32,000 ppm NaCl, 5 ppm Boron (SW30HR-380), 800 psi (5.5 MPa), 77°F (25°C), pH 8 and 8% recovery. Permeate flow rates for individual elements may vary +/-15%. Sales specifications may vary as design revisions take place.

Recommended Operating Conditions

• Membrane Type: Polyamide Thin-Film Composite	• Maximum Feed Water Silt Density Index 5 SDI
• Maximum Operating Temperature 113°F (45°C)	• Free Chlorine Tolerance^c <0.1 ppm
• Feed water pH Range (Continuous)^a 2-11	• Maximum Pressure Drop 15 psig (1 bar)
• Feed water pH Range (Cleaning)^b 1-13	• Maximum Operating Pressure 1,000 psig (69 bar) (SW30HRLE: 1,200 psig)

^a Maximum temperature for continuous operation above pH 10 is 95°F (35°C). ^b Refer to Cleaning Guidelines in spec sheet 609-23010.

^c Under certain conditions, the presence of free chlorine and other oxidizing agents will cause premature membrane failure. Since oxidation damage is not covered under warranty, FilmTec recommends removing residual free chlorine by pretreatment prior to membrane exposure. Please see individual products' specification sheet for operating limits and guidelines

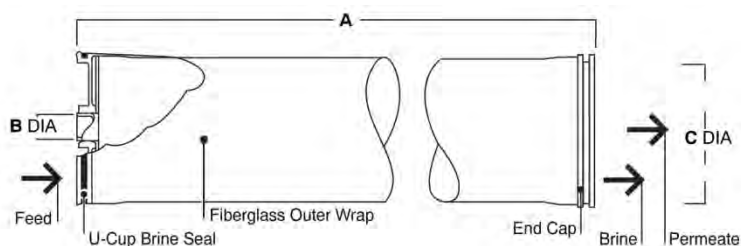

Model No.	A		B		C	
	inches	mm	inches	mm	inches	mm
SW30HR-380	40	1,016	1.125	29	7.9	201
SW30HRLE-400	40	1,016	1.125	29	7.9	201
SW30-6040	40	1,016	1.27	32.3	5.97	151.6

Visit us on the web for our complete product line and in-depth technical information. www.appliedmembranes.com

APPLIED MEMBRANES INC.®

ISO 9001:2008
Certified Company

(760) 727-3711 • FX: (760) 727-4427
sales@appliedmembranes.com

AM, APPLIED MEMBRANES INC., APPLIED ARE TRADEMARKS OF APPLIED MEMBRANES, INC. © 2012

iLEC™ Seawater RO Elements for Industrial Systems

A variety of FILMTEC seawater desalination elements are now available with iLEC interlocking end caps, an innovative element coupling technology that significantly enhances the performance of RO systems. Instead of using interconnectors to couple membranes end-to-end within a vessel, interlocking end caps twist directly together, reducing the number of sealing surfaces to a single axially compressed O-ring. The design reduces the potential for seal leakage, enabling sustained higher quality permeate, and reduces energy-consuming flow resistance, resulting in lower operating costs.

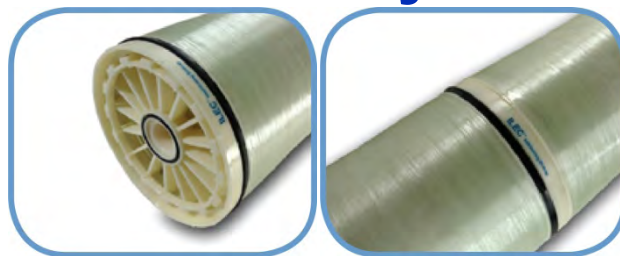

iLEC Interlocking Style Seawater Membranes

- SW30 offers 34 mil feed spacer to lessen the impact of fouling
- SW30XLE offers high productivity and low energy requirements
- SW30ULE offers highest productivity available
- SW30HRLE offers high NaCl and boron rejection
- SW30HR highest boron rejection

Model No.	Permeate Flow Rate		Size (Dia. " x Length")	Active Surface Area (Sq. Ft.)	Feed Spacer Thickness (mil)	Applied Pressure (psi)	Salt Rejection (%)		Stabilized Boron Rej. (%)
	gpd	m ³ /d					Stabilized	Min.	
SW30XLE-400i	9,000	34	8" x 40"	400	28	800	99.80	99.65	88
SW30XLE-440i	9,900	38	8" x 40"	440	28	800	99.80	99.65	88
SW30ULE-400i	11,000	42	8" x 40"	400	28	800	99.70	99.60	87
SW30ULE-440i	12,000	45	8" x 40"	440	28	800	99.70	99.60	89
SW30HRLE-370/34i	6,700	25	8" x 40"	370	34	800	99.80	99.65	92
SW30HRLE-400i	7,500	28	8" x 40"	400	28	800	99.80	99.65	92
SW30HRLE-440i	8,200	31	8" x 40"	440	28	800	99.80	99.65	92
SW30XHR-400i	6,000	23	8" x 40"	400	28	800	99.82	99.70	93

The above benchmark values are based on the following test conditions: 32,000 ppm NaCl, 5 ppm Boron, 800 psi (5.5 MPa), 77°F (25°C), pH 8 and 8% recovery. Permeate flows for individual elements may vary +/-15%. Product specifications may vary slightly as improvements are implemented.

Recommended Operating Conditions

• Membrane Type: Polyamide Thin-Film Composite	• Maximum Feed Water Silt Density Index	5 SDI
• Maximum Operating Temperature 113°F (45°C)	• Free Chlorine Tolerance ^c	<0.1 ppm
• Feed water pH Range (Continuous) ^a 2-11	• Maximum Pressure Drop	15 psig (1 bar)
• Feed water pH Range (Cleaning) ^b 1-13		

^a Maximum temperature for continuous operation above pH 10 is 95°F (35°C). ^b Refer to Cleaning Guidelines in spec sheet 609-23010.

^c Under certain conditions, the presence of free chlorine and other oxidizing agents will cause premature membrane failure. Since oxidation damage is not covered under warranty, FilmTec recommends removing residual free chlorine by pretreatment prior to membrane exposure. Please see individual products' specification sheet for operating limits and guidelines

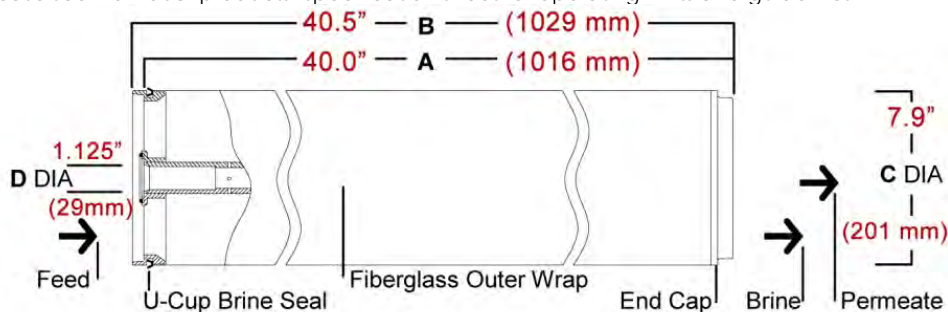

Visit us on the web for our complete product line and in-depth technical information. www.appliedmembranes.com

APPLIED MEMBRANES INC.®

ISO 9001:2008 Certified Company

(760) 727-3711 • FX: (760) 727-4427
sales@appliedmembranes.com

AM®, APPLIED MEMBRANES INC., APPLIED® ARE TRADEMARKS OF APPLIED MEMBRANES, INC. © 2012

Full Fit & Heat Sanitizable Membrane Elements

DOW FilmTec's full-fit configuration minimizes stagnant areas and is an ideal choice for applications requiring a sanitary design. All components comply with U.S. Food & Drug Administration standards.



- The DOW RO-390-FF product is a premier membrane for evaporator condensate polishing.
- HSRO heat sanitizable reverse osmosis membrane elements deliver exceptional quality water with the added capability to withstand sanitization with hot water.

Model No.	Permeate Flow Rate		Size (Dia. " × Length")	Active Surface Area (Sq. Ft.)	Applied Pressure (psi)	Stabilized Salt Rejection (%)
	gpd	m ³ /d				
RO-4040-FF	2,400	9.1	4" × 40"	85	225	99.5
HSRO-4040-FF	1,900	7.2	4" × 40"	90	150	99.5
RO-390-FF	10,800	40.9	8" × 40"	390	225	99.5
HSRO-390-FF	9,000	34.1	8" × 40"	390	150	99.5

Permeate flow and salt rejection based on the following test conditions: 2,000 ppm NaCl, pressure specified above, 77°F (25°C) and 15% recovery. Elements must be conditioned prior to start-up. A one-time flux loss will occur during stabilization. Listed values apply after performance stabilization. Permeate flows for individual elements may vary +/-20%.

Recommended Operating Conditions

• Membrane Type: Thin-Film Composite	• Maximum Feed Water Silt Density Index 5 SDI
• Maximum Operating Temperature 113°F (45°C)	• Maximum Operating Pressure 600 psig (41 bar)
• Maximum Sanitizing Temp. (HSRO) 185°F (85°C)	• Maximum Pressure Drop 15 psig (1 bar)
• Feed water pH Range (Continuous)^a RO: 3-10 HSRO: 2-11	• Free Chlorine Tolerance^c RO: Below detectable amounts HSRO: <0.1 ppm
• Feed water pH Range (Cleaning)^b 1-12	

^a Maximum temperature for continuous operation above pH 10 is 95°F (35°C). ^b Refer to Cleaning Guidelines in spec sheet 609-23010.

^c Under certain conditions, the presence of free chlorine and other oxidizing agents will cause premature membrane failure. Since oxidation damage is not covered under warranty, FilmTec recommends removing residual free chlorine by pretreatment prior to membrane exposure. Please see individual products' specification sheet for operating limits and guidelines

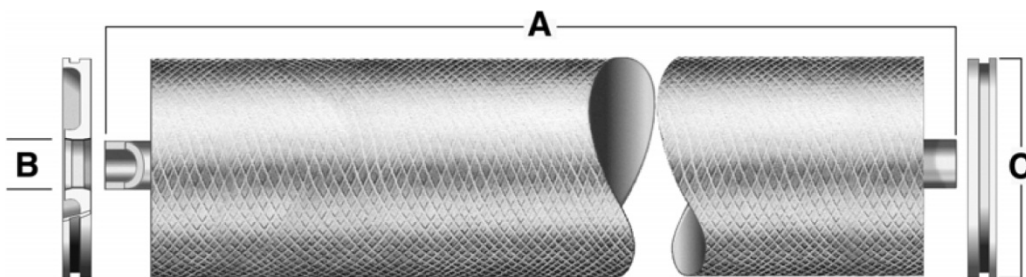

Model No.	A		B		C	
	inches	mm	inches	mm	inches	mm
RO-4040-FF	40	1,016	0.75	19	3.9	99
HSRO-4040-FF	40	1,016	0.75	19	3.9	99
RO-390-FF	40	1,016	1.125	28.58	7.9	200
HSRO-390-FF	40	1,016	1.125	28.58	7.9	200

Visit us on the web for our complete product line and in-depth technical information. www.appliedmembranes.com

APPLIED MEMBRANES INC.®

**ISO 9001:2008
Certified Company**

(760) 727-3711 • FX: (760) 727-4427
sales@appliedmembranes.com

AM, APPLIED MEMBRANES INC., APPLIED ARE TRADEMARKS OF APPLIED MEMBRANES, INC. © 2012

Nanofiltration Membrane Elements

The DOW™ FILMTEC™ NF270 membrane elements are ideal for removing a high percentage of TOC and THM precursors with medium to high salt passage and medium hardness passage. The DOW FILMTEC NF270 membrane is an ideal choice for surface water and ground water where good organic removal is desired with partial softening.

The DOW FILMTEC™ NF90 membrane elements provide high productivity performance while removing a high percentage of salts, nitrate, iron and organic compounds such as pesticides, herbicides and THM precursors. The low net driving pressure of the NF90 membrane allows the removal of these compounds at low operating pressures.



Nanofiltration Elements

Model No.	Permeate Flow Rate		Size (Dia. " × Length")	Applied Pressure (psi)	Stabilized Salt Rejection (%)
	gpd	m ³ /d			
NF270-2540	850 ¹	3.2	2.5" × 40"	70	>97.0 ¹
NF90-2540	680 ¹	2.6	2.5" × 40"	70	>97.0 ¹
NF270-4040	2,500 ¹	9.5	4" × 40"	70	>97.0 ¹
NF90-4040	2,000 ¹	7.6	4" × 40"	70	>97.0 ¹
NF270-400	CaCl ₂ : 14,700 ² MgSO ₄ : 12,500 ²	CaCl ₂ : 55.6 ² MgSO ₄ : 47.3 ²	8" × 40"	70	CaCl ₂ : 40-60 ² MgSO ₄ : >97 ²
NF90-400	NaCl: 7,500 ³ MgSO ₄ : 9,500 ³	NaCl: 28.4 ³ MgSO ₄ : 36.0 ³	8" × 40"	70	NaCl: 85-95 ³ MgSO ₄ : > 97 ³

¹ Permeate flow and salt passage based on: 2000 mg/l MgSO₄, 70 psi (0.48 MPa), and 77 °F (25°C) and 15% recovery.

² Permeate flow and salt passage based on: 500 mg/l CaCl₂ or 2000 mg/l MgSO₄, 70 psi (0.48 MPa), 77 °F (25°C), 15% recovery.

³ Permeate flow and salt passage based on: 2,000 mg/l NaCl or 2000 mg/l MgSO₄, 70 psi (0.48 MPa), 77 °F (25°C), 15% recovery.

Recommended Operating Conditions

• Membrane Type: Polyamide Thin-Film Composite	• Maximum Feed Water Silt Density Index SDI 5
• Maximum Operating Temperature 113°F (45°C)	• Free Chlorine Tolerance <0.1 ppm
• Maximum Operating Pressure 600 psig (41 bar)	• Maximum Feed Flow: 2.5" Dia.: 6 gpm 4" Dia.: 16 gpm 8" Dia.: 7 gpm
• Feed water pH Range (Continuous) 2.5 & 4" Dia.: 2-11 8" Dia.: 3-10	• Maximum Pressure Drop 2.5" Dia.: 13 psig (0.9 bar) 4" & 8" Dia.: 15 psig (1.0 bar)
• Feed water pH Range (Cleaning) 2.5 & 4" Dia.: 1-12 8" Dia.: 1-13	

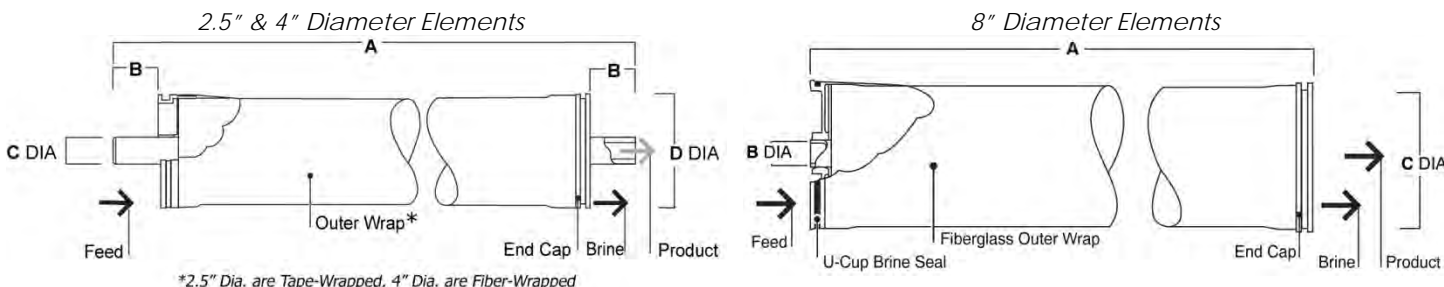

Model No.	A		B		C		D	
	inches	mm	inches	mm	inches	mm	inches	mm
NF270-2540, NF90-2540	40.0	1016	1.19	30	0.75	19	2.4	61
NF270-4040, NF90-4040	40.0	1016	1.05	27	0.75	19	3.9	99

Model No.	A		B		C	
	inches	mm	inches	mm	inches	mm
NF270-400, NF90-400	40	1,016	1.5	38	7.9	201

Visit us on the web for our complete product line and in-depth technical information. www.appliedmembranes.com

APPLIED MEMBRANES INC.®

ISO 9001:2008 Certified Company

(760) 727-3711 • FX: (760) 727-4427
sales@appliedmembranes.com

AM, APPLIED MEMBRANES INC., APPLIED ARE TRADEMARKS OF APPLIED MEMBRANES, INC. © 2012

Hollow Fiber Ultrafiltration Modules

About DOW™ Ultrafiltration

The DOW™ Ultrafiltration module utilizes a double-walled hollow fiber (capillary) PVDF membrane which has a very small nominal pore diameter for PVDF material that allows for the removal of all particulate matter, bacteria and most viruses and colloids. Despite the small pore diameter, the membrane has a very high porosity resulting in a flux similar to that of micro-filtration (MF) and can effectively replace MF in most cases.

Systems designed with DOW Ultrafiltration use an outside-in flow configuration which allows for less plugging, higher solids loading, higher flow area and easy cleaning. The primary flow design is dead-end filtration but the module can be operated using a concentrate bleed. Dead-end filtration uses less energy and has a lower operating pressure than the concentrate bleed, therefore reducing operating costs.

Typically, DOW Ultrafiltration is operated at a constant permeate flow. The transmembrane pressure (TMP) will naturally increase over time and the module can be cleaned periodically by back flushing and air scouring to remove the fouling layer. Disinfectants and other cleaning agents can be used to fully remove and prevent performance loss due to biological growth as well as other foulants.

DOW™ Ultrafiltration Advantages

- Low fouling Hydrophilic Polyvinylidene fluoride (H-PVDF) membrane
- Excellent filtration performance with high flux
- Durable and break resistant double-walled fiber structure
- High chemical resistance and temperature tolerance for effective membrane cleaning
- Very fine nominal pore diameter (0.03 µm)
- High removal efficiency of bacteria and viruses
- Dead-end or concentrate bleed flow capabilities
- Outside-In flow configuration that allows for less plugging and higher solids loading, higher flow area and easier cleaning
- Can be periodically back washed and air scoured to improve performance and extend operating life by removing the fouling layer
- Simple, vertical, modular design allows low cost, compact systems



DOW™ UF Specifications Ordering Information

Model No.	Size	Flow Range		Membrane Area		Module Volume		Weight-EMPTY		Weight-Water FILLED	
		gpm	m ² /hr	ft ²	m ²	gallons	liters	lbs	kg	lbs	kg
Pretreatment Models											
SFP-2660	6" x 60"	5.9 – 17.3	1.3 – 4.0	355	33	4.2	16	25	55	41	90
SFP-2860	8" x 60"	9.2 – 26.7	2.0 – 6.1	549	51	9.3	35	106	48	183	83
SFP-2880	8" x 80"	3.1 – 9.3	13.6 – 40.9	829	77	10.3	39	135	61	220	100
NSF/ANSI 61 Drinking Water Models											
SFD-2660	6" x 60"	5.9 – 17.3	1.3 – 4.0	355	33	4.2	16	25	55	41	90
SFD-2860	8" x 60"	9.2 – 26.7	2.0 – 6.1	549	51	9.3	35	106	48	183	83
SFD-2880	8" x 80"	3.1 – 9.3	13.6 – 40.9	829	77	10.3	39	135	61	220	100

Recommended Operating Conditions

• Filtrate Flux @ 25°C	24 – 70 gfd (40 – 120 l/m ² /hr)	• NaOCl (max)	2,000 mg/l
• pH, Operating	2-11	• TSS (max)	100 mg/l
• Temperature	34 – 104°F (1 – 40°C)	• Turbidity (max)	300 ntu
• Max. Inlet Module Pressure (@20°C)	93.75 psi (6.25 bar)	• Particle Size (max)	300 µm
• Max. Operating TMP	30 psi (2.1 bar)	• Flow Configuration	Outside In, Dead End Flow
• Max. Operating Air Scour Flow	7.1 scfm (12 Nm ³ /hr)	• Expected Filtrate Turbidity	≤ 0.1 NTU
• Max. Backwash Pressure	36 psi (2.5 bar)	• Expected Filtrate SDI	≤ 2.5

Visit us on the web for our complete product line and in-depth technical information. www.appliedmembranes.com

APPLIED MEMBRANES INC.®

ISO 9001:2008 Certified Company

(760) 727-3711 • FX: (760) 727-4427
sales@appliedmembranes.com

AM, APPLIED MEMBRANES INC., APPLIED ARE TRADEMARKS OF APPLIED MEMBRANES, INC. © 2012

ESPA® Ultra Low Pressure Membrane Elements

ESPA SERIES – Ultra Low Pressure Brackish Water RO Membranes

- **ESPA1** – High Productivity, energy saving membranes
- **ESPA2-LD** – New technology for higher productivity; minimizes bio-fouling & colloidal fouling; enhanced cleanability
- **ESPA2 MAX** – Highest productivity at the highest rejection level
- **ESPA4-LD & ESPA4 MAX**– Extra Low energy membranes with high productivity & rejection



Model No.	Size (Dia." x Length")	Flow Rate		Test Pressure (psi)	Nominal Salt Rejection (%)	Minimum Salt Rejection (%)
		gpd	m ³ /d			
ESPA-2514	2.5" x 14"	250	0.9	150	99.4	98.0
ESPA-2521	2.5" x 21"	350	1.3	150	99.4	98.0
ESPA-2540	2.5" x 40"	750	2.8	150	99.4	98.0
ESPA-4014	4" x 14"	500	1.9	150	99.4	98.0
ESPA-4021	4" x 21"	1,000	3.8	150	99.4	98.0
ESPA1-4040	4" x 40"	2,600	9.8	150	99.3	99.0
ESPA2-LD-4040	4" x 40"	2,000	7.6	150	99.6	99.4
ESPA4-4040	4" x 40"	2,500	9.5	100	99.2	99.0
ESPA1	8" x 40"	12,000	45.4	150	99.3	99.0
ESPA2-LD	8" x 40"	10,000	37.9	150	99.6	99.5
ESPA2MAX	8" x 40"	12,000	45.4	150	99.6	99.5
ESPA4-LD	8" x 40"	12,000	45.4	100	99.2	99.0
ESPA4MAX	8" x 40"	13,200	50.0	100	99.2	99.0

ESPAB Series – Boron Removal

- Provides a new option for communities where boron levels are naturally high or for manufacturers challenged by boron contamination issues.

Model No.	Size (Dia." x Length")	Flow Rate		Test Pressure (psi)	Salt Rejection (%)		Ave. Boron Rej. (%@10psi)
		gpd	m ³ /d		Nominal	Minimum	
ESPABMAX	8" x 40"	9,000	34.1	150	99.3	99	99.6

Applications

- Municipal Potable and Wastewater Plants
- Bottling Operations
- Light Industrial

Advantages

- 99-99.6% Nominal Rejection
- Lower Pressure for Lower CAPEX-OPEX

Recommended Operating Conditions and Technical Information

• Configuration:	Spiral Wound	• Maximum Feedwater Turbidity	1.0 NTU
• Membrane Polymer:	Composite Polyamide	• Feedwater pH Range:	3-10
• Maximum Chlorine Concentration:	<0.1 ppm	• Maximum Single-Element Recovery Ratio:	5:1
• Maximum Operating Temperature:	113°F (45°C)	• Maximum Single-Element Pressure Drop:	10 psi
• Maximum Feedwater SDI (15 mins):	2.5" Dia. & 4" 14 & 21"L: 4.0 4x40" & 8"x40": 5.0	• Maximum Applied Pressure:	2.5" Dia. & 4" 14 & 21"L: 300 psi 4x40" & 8"x40": 600 psi

Note: Performance specifications based on 1,500 ppm NaCl solution (ESPA4 500 ppm NaCl), 77°F (25°C) feed water temperature, feed water pH 6.5-7, 15% recovery and applied pressures as listed above. Element permeate flow may vary +35% or -15%. See technical literature for extended pH tolerance and additional application data.

Visit us on the web for our complete product line and in-depth technical information. www.appliedmembranes.com

APPLIED MEMBRANES INC.®

**ISO 9001:2008
Certified Company**

(760) 727-3711 • FX: (760) 727-4427
sales@appliedmembranes.com

AM, APPLIED MEMBRANES INC., APPLIED ARE TRADEMARKS OF APPLIED MEMBRANES, INC. © 2012

CPA High Rejection Membrane Elements

CPA SERIES – Highest Rejection Brackish Water RO Membranes

CPA (Composite Polyamide) elements set the standard for RO membrane elements – over 600 million gallons per day of pure water are produced by CPA elements for global municipalities and industries.

- **CPA2** – “The Workhorse” Most widely used with consistent performance
- **CPA3** – Best combination of productivity and salt rejection available
- **CPA5-LD Series** – New technology minimizing bio-fouling and colloidal fouling and enhancing cleanability



Model No.	Size (Dia. × Length")	Flow Rate		Test Pressure (psi)	Nominal Salt Rejection (%)	Minimum Salt Rejection (%)
		gpd	m ³ /d			
CPA2-4040	4" × 40"	2,250	8.5	225	99.5	99.2
CPA5-LD-4040	4" × 40"	2,100	7.95	225	99.7	99.5
CPA3	8" × 40"	11,000	41.6	225	99.7	99.6
CPA5-LD	8" × 40"	11,000	41.6	225	99.7	99.6
CPA5MAX	8" × 40"	12,000	45.4	225	99.7	99.6

Applications

- Desalting of Well Waters – Municipal Drinking Water
- Reducing TDS Prior to Ion Exchange
- Boiler Make-up Water
- Ultrapure Water For Semiconductor Manufacture

Advantages

- 99.7% Nominal Rejection
- High TOC, Silica and Hardness Rejection

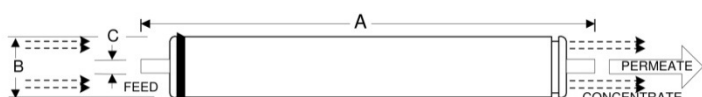

4" × 40"

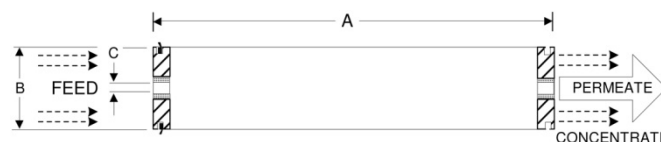

8" × 40"

Model No.	A		B		C	
	inches	mm	inches	mm	inches	mm
CPA2-4040, CPA5-LD-4040	40	1,016	3.95	100.3	0.75	19.1
CPA3, CPA5-LD, CPA5 MAX	40	1,016	7.89	200	1.125	28.6

Recommended Operating Conditions and Technical Information

• Configuration:	Spiral Wound	• Maximum Feedwater Turbidity	1.0 NTU
• Membrane Polymer:	Composite Polyamide	• Maximum Feedwater SDI:	5 (15 min.)
• Maximum Chlorine Concentration:	<0.1 ppm	• Maximum Single-Element Recovery Ratio:	5:1
• Maximum Operating Temperature:	113°F (45°C)	• Maximum Single-Element Pressure Drop:	10 psi
• Feedwater pH Range:	3-10	• Maximum Applied Pressure:	600 psi

Note: Performance specifications based on 1,500 ppm NaCl solution, 77°F (25°C) feed water temperature, feed water pH 6.5-7, 15% recovery and applied pressures as listed above. Element permeate flow may vary +35% or -15%. See technical literature for extended pH tolerance and additional application data.

Visit us on the web for our complete product line and in-depth technical information. www.appliedmembranes.com

APPLIED MEMBRANES INC.

ISO 9001:2008
Certified Company

(760) 727-3711 • FX: (760) 727-4427
sales@appliedmembranes.com

AM, APPLIED MEMBRANES INC., APPLIED ARE TRADEMARKS OF APPLIED MEMBRANES, INC. © 2012

LFC® Low Fouling Membrane Elements

LFC SERIES – Low Fouling Brackish Water RO Elements

LFC® (Low Fouling Composite) elements combine neutral surface charge and hydrophilicity, providing significant reduction in fouling rates and increasing membrane efficiency by restoring nominal performance after cleaning. The LFC3-LD is designed with a thicker brine spacer lowering the Delta P meeting the increased demand for lower fouling membranes that require less frequent cleanings while maintaining a high permeate flow. The LFC3-LD provides 11,000 gallons per day (41.6 m³/d) of flow at 99.7% nominal salt rejection. This membrane is well suited for the treatment of difficult feed waters for numerous municipal and industrial applications, which up to now required significant feed water pretreatment upstream of any composite reverse osmosis membrane.



Model No.	Size (Dia." × Length")	Flow Rate		Test Pressure (psi)	Nominal Salt Rejection (%)	Minimum Salt Rejection (%)
		gpd	m ³ /d			
LFC3-LD-4040	4" × 40"	2,100	7.95	225	99.7	99.5
LFC3-LD	8" × 40"	11,000	41.6	225	99.7	99.5

Applications

- Municipal/Industrial surface and waster waters
- Difficult feed waters requiring significant pretreatment

Advantages

- 99.7% Nominal rejection
- Low fouling membrane chemistry reduces or eliminates pre-treatment
- LD technology increases brine spacer thickness for reduced differential pressures
- Lower cleaning frequency and costs

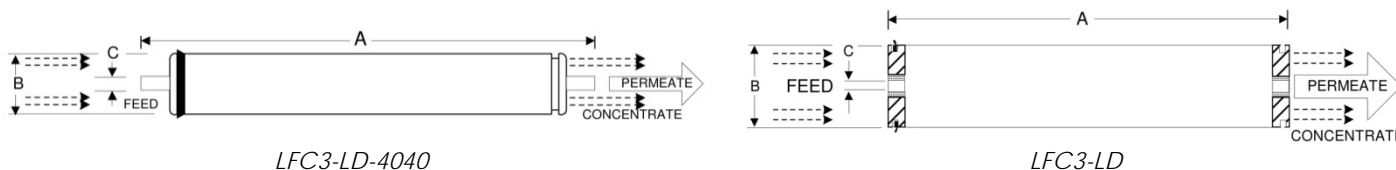

Model No.	A		B		C	
	inches	mm	inches	mm	inches	mm
LFC3-LD-4040	40	1,016	3.95	100.3	0.75	19.1
LFC3-LD	40	1,016	7.89	200	1.125	28.6

Recommended Operating Conditions and Technical Information

• Configuration:	Spiral Wound	• Maximum Feedwater Turbidity	1.0 NTU
• Membrane Polymer:	Composite Polyamide	• Maximum Feedwater SDI:	5 (15 min.)
• Maximum Chlorine Concentration:	<0.1 ppm	• Maximum Single-Element Recovery Ratio:	5:1
• Maximum Operating Temperature:	113°F (45°C)	• Maximum Single-Element Pressure Drop:	10 psi
• Feedwater pH Range:	3-10	• Maximum Applied Pressure:	600 psi

Note: Performance specifications based on 1,500 ppm NaCl solution, 77°F (25°C) feed water temperature, feed water pH 6.5-7, 15% recovery and applied pressures as listed above. Element permeate flow may vary +35% or -15%. See technical literature for extended pH tolerance and additional application data.

Visit us on the web for our complete product line and in-depth technical information. www.appliedmembranes.com

APPLIED MEMBRANES INC.®

**ISO 9001:2008
Certified Company**

(760) 727-3711 • FX: (760) 727-4427
sales@appliedmembranes.com

AM, APPLIED MEMBRANES INC., APPLIED ARE TRADEMARKS OF APPLIED MEMBRANES, INC. © 2012

SWC® Seawater Membrane Elements

SWC SERIES – Seawater Desalination RO Membranes

SWC seawater desalination elements offer the highest levels of salt rejection and a consistently pure end product. Membrane formulations are designed to accommodate varying levels of seawater salinities worldwide with reliable field-proven performance.

- **SWC4B MAX** – Highest Boron Rejection Available (95% average)†
- **SWC5 MAX, SWC5-LD** – Lower Fouling for Maximum Performance
- **SWC6-4040, SWC6, SWC6 MAX** – Highest Permeate Flow Rate Available with 91% Average Boron Rejection†



Model No.	Size (Dia. × Length")	Flow Rate		Test Pressure (psi)	Nominal Salt Rejection (%)	Minimum Salt Rejection (%)
		gpd	m ³ /d			
SWC-2514	2.5" × 14"	110	0.4	800	99.4	99.0
SWC-2521	2.5" × 21"	220	0.8	800	99.4	99.0
SWC-2540	2.5" × 40"	520	2.0	800	99.4	99.0
SWC-4014	4" × 14"	370	1.4	800	99.4	99.0
SWC-4021	4" × 21"	640	2.4	800	99.4	99.0
SWC5-LD-4040	4" × 40"	1,750	6.6	800	99.7	99.5
SWC6-4040	4" × 40"	2,500	7.2	800	99.7	99.5
SWC4BMAX	8" × 40"	7,200	27.3	800	99.8	99.7
SWC5-LD	8" × 40"	9,000	34.1	800	99.8	99.7
SWC5MAX	8" × 40"	9,900	37.5	800	99.8	99.7
SWC6	8" × 40"	12,000	45.5	800	99.8	99.7
SWC6MAX	8" × 40"	13,200	50	800	99.8	99.7

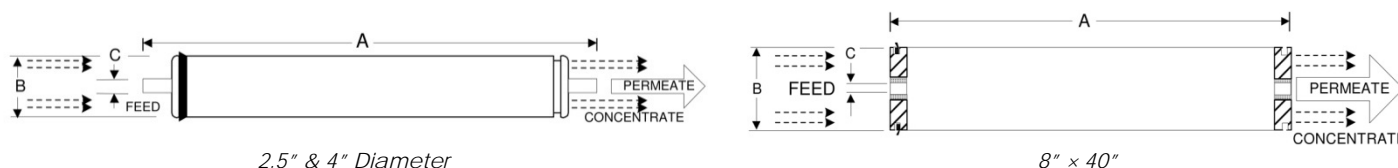

2.5" & 4" Diameter

8" × 40"

Model No.	A		B		C		Maximum Feed Flow	
	inches	mm	inches	(gpm)	inches	mm	gpm	m ³ /h
SWC-2514	14	355.6	2.4	61	0.75	19.1	6	1.4
SWC-2521	21	533.4	2.4	61	0.75	19.1	6	1.4
SWC-2540	40	1,016	2.4	61	0.75	19.1	6	1.4
SWC-4014	14	355.6	3.95	100.3	0.75	19.1	12	2.7
SWC-4021	21	533.4	3.95	100.3	0.75	19.1	12	2.7
SWC – All 4"×40"	40	1,016	3.95	100.3	0.75	19.1	16	3.6
SWC – All 8"×40"	40	1,016	7.89	200	1.125	28.6	75	17.0

Recommended Operating Conditions and Technical Information

• Configuration:	Spiral Wound	• Maximum Feedwater	2.5" Dia. & 4" 14 & 21"L: 4.0
• Membrane Polymer:	Composite Polyamide	• SDI (15 mins):	4×40" & 8"×40": 5.0
• Maximum Chlorine Concentration:	<0.1 ppm	• Maximum Single-Element Recovery Ratio:	5:1
• Maximum Operating Temperature:	113°F (45°C)	• Maximum Single-Element Pressure Drop:	10 psig
• Maximum Feedwater Turbidity	1.0 NTU	• Maximum Applied	2.5" Dia. & 4" 14 & 21"L: 1,000 psig
• Feedwater pH Range:	2.5" Dia. & 4" 14 & 21"L: 3-10 4×40" & 8"×40": 2-11	• Pressure:	4×40" & 8"×40": 1,200 psig

Note: Performance specifications based on 32,000 ppm NaCl solution, 77°F (25°C) feed water temperature, feed water pH 6.5-7, 10% recovery and applied pressures as listed above. Element permeate flow may vary +35% or -15%. See technical literature for extended pH tolerance and additional application data. †When tested at standard conditions with 5.0ppm Boron in feed solution.

Visit us on the web for our complete product line and in-depth technical information. www.appliedmembranes.com

APPLIED MEMBRANES INC.®

ISO 9001:2008
Certified Company

(760) 727-3711 • FX: (760) 727-4427
sales@appliedmembranes.com

AM, APPLIED MEMBRANES INC., APPLIED ARE TRADEMARKS OF APPLIED MEMBRANES, INC. © 2012

Nanofiltration Membrane Elements

ESNA SERIES – Energy Saving Nanofiltration (NF) Membranes

High performance energy savings ESNA nanofiltration membrane elements are ideal for softening applications and the removal of pesticides, bacteria or viruses. They provide 50%-90% salt rejection with ultra-low-pressure operations, increased energy savings, and significantly lower installation and operating costs. They can effectively remove organics which can form disinfection by-products in municipal water distribution lines. At the Boca Raton plant the THM formation potential was reduced from 0.6 mg/L to less than 0.020 mg/L, well below the 0.042 mg/L limit.

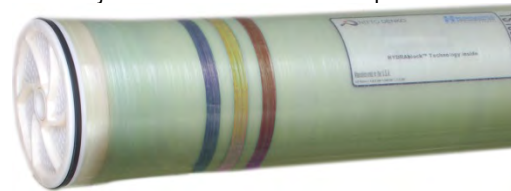

Advantages

- Municipal Water Treatment
- New technology for higher productivity; minimizes bio-fouling and colloidal fouling and enhancing cleanability

Applications

- Up to 91% nominal rejection
- Effectively removes organics
- Optimum hardness rejection
- Ultra-low pressure, energy saving, lower OPEX

Model No.	Size (Dia. " × Length")	Flow Rate		Test Pressure (psi)	Nominal CaCl ₂ Rejection (%)	Minimum CaCl ₂ Rejection (%)
		gpd	m ³ /d			
ESNA1-LF-LD-4040	4" × 40"	1,700	6.4	75	89	86
ESNA1-LF2-LD-4040	4" × 40"	2,000	7.6	75	86	83
ESNA1-LF-LD	8" × 40"	8,200	31.0	75	89	86
ESNA1-LF2-LD	8" × 40"	10,500	39.7	75	86	83

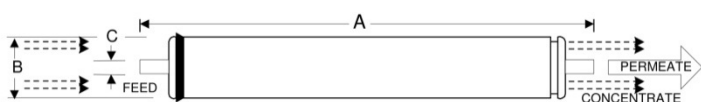

ESNA1-LF-LD-4040 & ESNA1-LF2-LD-4040

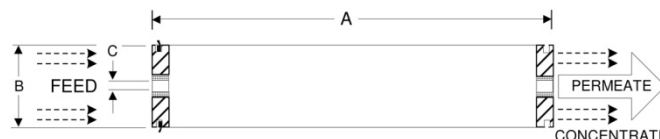

ESNA1-LF-LD & ESNA1-LF2-LD

Model No.	A		B		C		Maximum Feed Flow	
	inches	mm	inches	mm	inches	mm	gpm	m ³ /h
ESNA1-LF-LD-4040 & ESNA1-LF2-LD-4040	40	1,016	3.95	100.3	0.75	19.1	16	3.6
ESNA1-LF-LD & ESNA1-LF2-LD	40	1,016	7.89	200	1.125	28.6	75	17

Recommended Operating Conditions and Technical Information

• Configuration:	Spiral Wound	• Maximum Feedwater	LF-LD	5.0
• Membrane Polymer:	Composite Polyamide	• SDI (15 mins):	LF2-LD	4.0
• Maximum Chlorine Concentration:	<0.1 ppm	• Maximum Single-Element Recovery Ratio:		5:1
• Maximum Operating Temperature:	113°F (45°C)	• Maximum Single-Element Pressure Drop:		10 psi
• Feedwater pH Range:	2-10	• Maximum Applied Pressure:		600 psi
• Maximum Feedwater Turbidity	1.0 NTU			

Note: Performance specifications based on 500 ppm CaCl solution, 77°F (25°C) feed water temperature, feed water pH 6.5-7, 15% recovery and applied pressures as listed above. Element permeate flow may vary +25% or -25%. See technical literature for extended pH tolerance and additional application data.

Visit us on the web for our complete product line and in-depth technical information. www.appliedmembranes.com

APPLIED MEMBRANES INC.

ISO 9001:2008
Certified Company

(760) 727-3711 • FX: (760) 727-4427
sales@appliedmembranes.com

AM, APPLIED MEMBRANES INC., APPLIED ARE TRADEMARKS OF APPLIED MEMBRANES, INC. © 2012

HYDRAcap® Ultrafiltration Modules

HYDRAcap is used to treat surface water, ground water, seawater and waste water as either primary treatment or as pre-treatment to reverse osmosis (RO) and Nano filtration (NF). Compared to conventional pretreatment, HYDRAcap allows higher fluxes for RO and NF systems while maintaining longer intervals between cleanings. In some cases it replaces conventional pretreatment for portable applications, ground water recharging and water recycling.



HYDRAcap® Advantages and Performance

- Low fouling hydrophilic polyethersulfone membrane
- Tolerant to chlorine, peroxide and other oxidants.
- Resistant to pH extremes
- Filtrate Turbidity: ≤ 0.07 NTU
- Virus & Bacteria Removal: ≥ 4 log
- TOC Reduction: 5 – 65%
- MWCO, nominal: 150,000 Daltons
- Operating Mode: Inside to Outside Filtration; Direct flow or Crossflow

HYDRAcap and HYDRAcap LD

- The 0.8 mm **HYDRAcap** is used for surface water applications containing lower turbidities.
- The 1.2 mm **HYDRAcapLD** offers a 50% larger capillary diameter for a wider range of high fouling applications.

Model No.	Filtrate Flow Rate		Nominal Membrane Area	Number of Fibers	Fiber Dimensions	
	gpm	m ³ /h			ID	OD
HYDRAcap40	7 – 19	1.6 – 4.4	320 ft ²	13,200	0.031" (0.8 mm)	0.051" (1.3 mm)
HYDRAcap40-LD	5 – 12.3	1.1 – 2.8	208 ft ²	5,600	0.047" (1.2 mm)	0.080" (2.0 mm)
HYDRAcap60	11 – 30	2.7 – 6.8	500 ft ²	13,200	0.031" (0.8 mm)	0.051" (1.3 mm)
HYDRAcap60-LD	7.8 – 19	1.8 – 4.3	323 ft ²	5,600	0.047" (1.2 mm)	0.080" (2.0 mm)

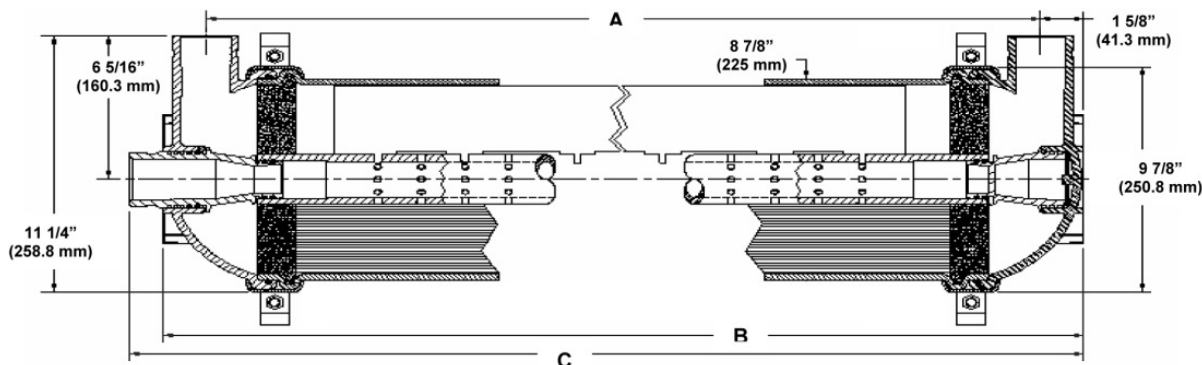

Model No.	A		B		C		Pipe Connections	Average Weight	
	inches	mm	inches	mm	inches	mm		lb	kg
HYDRAcap40, 40-LD	43	1092	46 1/8	1172	47 1/4	1200	2" Victaulic	63	28
HYDRAcap80, 60-LD	63	1600	66 1/8	1680	67 1/4	1708	2" Victaulic	97	44

Note: Performance listed is typical module performance for most feedwaters. Typical TOC rejection is 5-15% without coagulant and 40-65% with coagulant. Refer to product specification sheets for application data and typical process conditions.

Visit us on the web for our complete product line and in-depth technical information. www.appliedmembranes.com

APPLIED MEMBRANES INC.®

ISO 9001:2008
Certified Company

(760) 727-3711 • FX: (760) 727-4427
sales@appliedmembranes.com

AM, APPLIED MEMBRANES INC., APPLIED ARE TRADEMARKS OF APPLIED MEMBRANES, INC. © 2012

Fluid Systems® RO Spiral Membrane Elements

KMS spiral reverse osmosis membranes are recognized for exceptional performance and dependability. TFC membranes excel at desalination as well as removing trace organics and reducing hardness. ROGA membranes are designed for high organic fouling environments, where chlorine may be present and are ideal for high rejection, low-pressure processes where oxidizing agents are a concern.



HR Series – High Rejection Low Pressure Thin Film Elements

Model No.	Size (Dia. " × L")	Permeate Flow		Chloride Rejection (%)	Test Pressure (psi)	Overwrap	Membrane Area		Feed Spacer	
		gpd	m ³ /d				(ft ²)	(m ²)	mil	mm
2540HR	2.5 × 40	750	2.8	99.40	225	Tape	27	2.5	31	0.8
4040-HR-T	4 × 40	2,270	8.6	99.55	225	Tape	85	7.9	28	0.7
4040-HR	4 × 40	2,270	8.6	99.55	225	Fiberglass	85	7.9	28	0.7
8040-HR-375	8 × 40	10,200	38.6	99.5	225	Fiberglass	375	34.8	31	0.8
8040-HR-400	8 × 40	11,000	41.6	99.5	225	Fiberglass	400	37.2	28	0.7

Test Conditions: 2,000 mg/l NaCl (700mg/l for 2.5") solution at 225 psi (1,550 kPa) applied pressure, 15% recovery, 77°F (25°C) and pH 7.5

XR Series – High Rejection Thin Film Elements

Model No.	Size (Dia. " × L")	Permeate Flow		Chloride Rejection (%)	Test Pressure (psi)	Overwrap	Membrane Area		Feed Spacer	
		gpd	m ³ /d				(ft ²)	(m ²)	mil	mm
4040-XR	4 × 40	2,200	8.3	99.75	325	Fiberglass	85	7.9	28	0.7
8040-XR-375	8 × 40	9,800	37.1	99.75	325	Fiberglass	375	34.8	31	0.8
8040-XR-400	8 × 40	10,500	39.7	99.75	325	Fiberglass	400	37.2	28	0.7

Test Conditions: 2,000 mg/l NaCl solution at 325 psi (2,240 kPa) applied pressure, 15% recovery, 77°F (25°C) and pH 7.5

ROGA Series – Chlorine Resistant High Rejection Cellulose Acetate RO Elements

Model No.	Size (Dia. " × L")	Permeate Flow		Chloride Rejection (%)	Test Pressure (psi)	Overwrap	Membrane Area		Feed Spacer	
		gpd	m ³ /d				(ft ²)	(m ²)	mil	mm
ROGA-4040-HR	4 × 40	1,700	6.4	98.0	420	Fiberglass	80	7.4	31	0.8
ROGA-8040-HR-325	8 × 40	7,100	26.9	98.0	420	Fiberglass	325	30.2	31	0.8

Test Conditions: 2,000 mg/l NaCl solution at 420 psi (2,900 kPa) applied pressure, 15% recovery, 77°F (25°C) and pH 5.7

SW Series – Seawater Elements

Model No.	Size (Dia. " × L")	Permeate Flow		Chloride Rejection (%)	Test Pressure (psi)	Overwrap	Membrane Area		Feed Spacer	
		gpd	m ³ /d				(ft ²)	(m ²)	mil	mm
2540-SW	2.5 × 40	520	2.0	99.5	800	Fiberglass	25	2.3	31	0.8
2540SWHF	2.5 × 40	700	2.6	99.5	800	Fiberglass	25	2.3	31	0.8
4040-SW	4 × 40	1,330	5.0	99.75	800	Fiberglass	74	6.9	31	0.8
8040-SW-335	8 × 40	6,000	22.7	99.75	800	Fiberglass	335	31.1	34	0.9
8040-SW-400	8 × 40	7,200	27.2	99.75	800	Fiberglass	400	37.2	28	0.7

Test Conditions: 32,800 mg/l NaCl solution (isotonic to ASTM standard seawater) at 800 psi (5,520 kPa) applied pressure, 7% recovery, 77°F (25°C) and pH 7.5

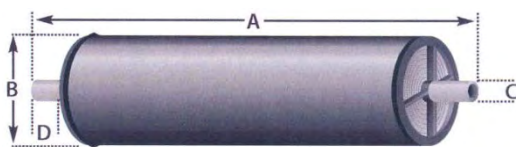

HR, XR, SW - 2.5"×40" & 4"×40"

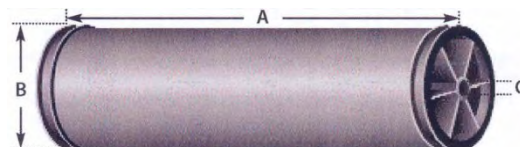

8"×40" & ROGA 4"×40"

Size	A		B		C		D		Weight	
	inches	mm	inches	mm	inches	mm	inches	mm	Lbs	kg
2.5"×40" (All)	40.0	1,016	2.4	61.0	0.75	19.0	1.0	25.4	3.0	1.4
4"×40" (HR, XR, SW)	40.0	1,016	4.0	101.6	0.75	19.0	1.0	25.4	10	4.5
4"×40" ROGA	40.0	1,016	4.0	101.6	0.625	15.9	n/a	n/a	10	4.5
8"×40" (All)	40.0	1,016	8.0	203	1.125	29	n/a	n/a	38	17

Visit us on the web for our complete product line and in-depth technical information. www.appliedmembranes.com

Brackish Water Membrane Elements

- Membrane Type: Cross-linked fully aromatic polyamide composite membrane
- High rejection TM700 series, for high salinity brackish water applications
- Ultra low pressure TMH and TMG series for low salinity brackish water applications
- Low fouling TML series for brackish water applications
- High rejection TM800 series, for sea water applications



TM700 Series – High Rejection Brackish Water RO Elements

Model No.	Size (Dia. " × L ")	Permeate Flow		Salt Rejection (%)	Test Pressure (psi)	Membrane Area		Feed Spacer	
		gpd	m ³ /d			(ft ²)	(m ²)	mil	mm
TM710	4 × 40	2,400	9.1	99.7	225	87	8	31	0.8
TM720-370	8 × 40	9,500	36.0	99.7	225	370	34	31	0.8
TM720-400	8 × 40	10,200	38.6	99.7	225	400	37	31	0.8
TM720N-400	8 × 40	10,200	38.7	99.7	225	400	37	34	0.9
TM720-440	8 × 40	11,300	42.8	99.7	225	440	41	28	0.7
<i>TM700C – Brackish with 95% Boron Rejection (at pH 10 & 5 ppm Feed)</i>									
TM720C-400	8 × 40	10,200	38.7	99.7	225	400	37	31	0.8
TM720C-440	8 × 40	11,300	42.8	99.7	225	440	41	28	0.7
<i>TM700L – Low Pressure High Rejection Brackish</i>									
TM720L-400	8 × 40	8,500	32.2	99.5	225	400	37	28	0.7
TM720L-440	8 × 40	9,200	34.8	99.5	225	440	41	28	0.7

Test Conditions: 2,000 mg/l NaCl solution at 225 psi (1.55 MPa) applied pressure, 15% recovery, 77°F (25°C) and pH 7. Minimum Salt Rejection is 99%.

TMG Series – Low Pressure Brackish Water RO Elements

Model No.	Size (Dia. " × L ")	Permeate Flow		Salt Rejection (%)	Test Pressure (psi)	Membrane Area		Feed Spacer	
		gpd	m ³ /d			(ft ²)	(m ²)	mil	mm
TMG10	4 × 40	2,400	9.1	99.5	110	87	8	31	0.8
TMG20-400	8 × 40	10,200	38.6	99.5	110	400	37	28	0.7
TMG20-400C*	8 × 40	10,200	38.6	99.5	110	400	37	31	0.8
TMG20N-400	8 × 40	10,200	38.6	99.5	110	400	37	34	0.9
TMG20N-400C*	8 × 40	10,200	38.6	99.5	110	400	37	34	0.9
TMG20-440	8 × 40	11,300	42.8	99.5	110	440	41	28	0.7
TMG20-440C*	8 × 40	11,300	42.8	99.5	110	440	41	28	0.7

Test Conditions: 500 mg/l NaCl solution at 110 psi (0.76 MPa) applied pressure, 15% recovery, 77°F (25°C) and pH 7. Minimum Salt Rejection is 99%.

*Elements ending in "C" contain 1.125" pwt.

TMH Series – Ultra Low Pressure Brackish Water RO Elements

Model No.	Size (Dia. " × L ")	Permeate Flow		Salt Rejection (%)	Test Pressure (psi)	Membrane Area		Feed Spacer	
		gpd	m ³ /d			(ft ²)	(m ²)	mil	mm
TMH10A	4 × 40	2,400	9.1	99.3	100	87	8	31	0.8
TMH20A-400	8 × 40	11,000	41.6	99.3	100	400	37	28	0.7
TMH20A-440	8 × 40	11,800	44.7	99.3	100	440	41	28	0.7

Test Conditions: 500 mg/l NaCl solution at 100 psi (0.69 MPa) applied pressure, 15% recovery, 77°F (25°C) and pH 7. Minimum Salt Rejection is 99%.

Visit us on the web for our complete product line and in-depth technical information. www.appliedmembranes.com

ISO 9001:2008
Certified Company

(760) 727-3711 • FX: (760) 727-4427
sales@appliedmembranes.com

AM, APPLIED MEMBRANES INC., APPLIED ARE TRADEMARKS OF APPLIED MEMBRANES, INC. © 2012

Brackish & Seawater Membrane Elements

TML Series – Low Fouling Brackish Water RO Elements

Model No.	Size (Dia. " × L")	Permeate Flow		Salt Rejection (%)	Test Pressure (psi)	Membrane Area		Feed Spacer	
		gpd	m ³ /d			(ft ²)	(m ²)	mil	mm
TML10	4 × 40	1,850	7.0	99.7	225	73	7	34	0.9
TML10F	4 × 40	2,200	8.3	99.7	225	87	8	31	0.8
TML20-370	8 × 40	9,500	36.0	99.7	225	370	34	34	0.9
TML20N-400	8 × 40	10,200	38.6	99.7	225	400	37	34	0.9

Test Conditions: 2,000 mg/l NaCl solution at 225 psi (1.55 MPa) applied pressure, 15% recovery, 77°F (25°C) and pH 7. Minimum Salt Rejection is 99%.

TM800 Series – Seawater Desalination RO Elements

Model No.	Size (Dia. " × L")	Permeate Flow		Salt Rejection (%)	Test Pressure (psi)	Membrane Area		Feed Spacer	
		gpd	m ³ /d			(ft ²)	(m ²)	mil	mm
<i>TM800B – Seawater with High Pressure Capability (Up to 1,400 PSI)</i>									
TM820B-400	8 × 40	5,600	21.2	99.75	800	400	37	31	0.8
<i>TM800C – Seawater with 93% Boron Rejection (at pH8 & 5mg/l feed)</i>									
TM810C	4 × 40	1,200	4.5	99.75	800	73	7	31	0.8
TM820C-370	8 × 40	6,000	22.7	99.75	800	370	34	31	0.8
TM820C-400	8 × 40	6,500	24.6	99.75	800	400	37	28	0.7
<i>TM800E – Energy Saving Seawater with 91% Boron Rejection (at pH8 & 5mg/l feed)</i>									
TM820E-400	8 × 40	7,500	28.3	99.75	800	400	37	28	0.7
<i>TM800F & TM800L – High Flow Seawater Elements</i>									
TM810L	4 × 40	1,900	7.2	99.70	800	73	7	28	0.7
TM810F	4 × 40	2,200	8.3	99.70	800	73	7	31	0.8
TM820F-400	8 × 40	9,000	34.1	99.70	800	400	37	28	0.7
<i>TM800S – High Flow Seawater with 90% Boron Rejection (at pH8 & 5mg/l feed)</i>									
TM820S-400	8 × 40	9,000	34.1	99.75	800	400	37	28	0.7

Test Conditions: 32,000 mg/l NaCl solution at 800 psi (5.52 MPa) applied pressure, 15% recovery, 77°F (25°C) and pH 8. Minimum Salt Rejection is 99.5%.

Dimensions of Toray Membranes

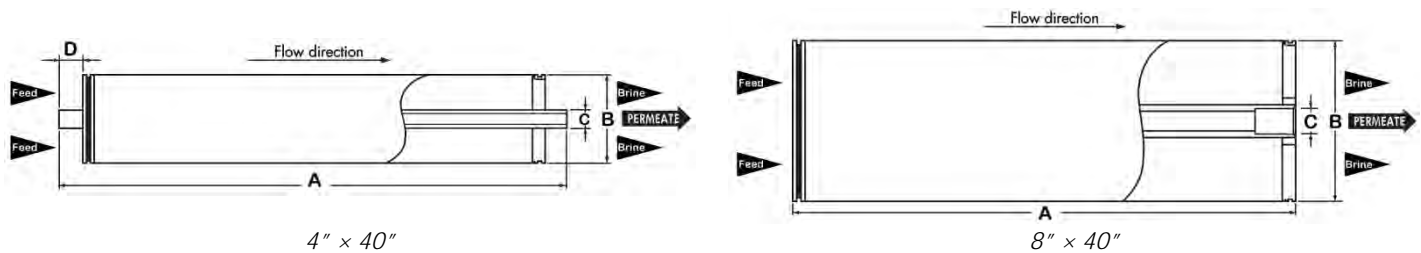

Model No.	A		B		C		D	
	inches	mm	inches	mm	inches	mm	inches	mm
4" × 40" (All)	40	1,016	4	101	0.75	19	1.05	26
8" × 40" Standard	40	1,016	7.9	201	1.50	38	n/a	n/a
8" × 40" "C" (Marked with *)	40	1,016	7.9	201	1.125	29	n/a	n/a

Visit us on the web for our complete product line and in-depth technical information. www.appliedmembranes.com

Inge Hollow Fiber UF Elements

Dizzer XL Modules & T-Rack Integrated

Dizzer® XL Series Ultrafiltration Modules for Large Scale Applications

- Complete Modules – No additional Pressure Housing Required
- Reliable Rejection of Microorganisms and Viruses
- Excellent Quality of Filtrate
- Efficient backwash and simple operation
- No fiber breaks – guaranteed quality
- Ideal for Pre-Treatment to Reverse Osmosis
- Easy Installation and Handling
- Welded Feed Connectors (Modules with filtrate clamps [to use for replacement in existing "old style" installations] are available upon request.)



Part #	Product Name	Size (Dia. × Length")	Membrane Type	Estimated Flow Rate* (gpm)		Membrane Area	
				Min.	Max.	sq. ft	m ²
DIZZERXL38	dizzer XL 0.9 MB 38	9 ⁷ / ₈ " × 46 ¹ / ₂ "	Multibore® 0.9	5.7	17.1	410	38
DIZZERXL25	dizzer XL 1.5 MB 25	9 ⁷ / ₈ " × 46 ¹ / ₂ "	Multibore® 1.5	3.8	11.3	270	25
DIZZERXL60	dizzer XL 0.9 MB 60	9 ⁷ / ₈ " × 66 ¹ / ₈ "	Multibore® 0.9	9.0	26.9	645	60
DIZZERXL40	dizzer XL 1.5 MB 40	9 ⁷ / ₈ " × 66 ¹ / ₈ "	Multibore® 1.5	6.0	17.9	430	40

***Design Notes:**

1. Individual UF modules can be configured in parallel to provide increased system capacities.
2. The individual UF module flow ranges depend upon the source water quality and pretreatment. Consult with AMI for specific design flow rates for a specific application.

Technical Information

- Housing: PVC-U, white with End Cap: PVC-U, grey and SS Coupling (sealing EPDM)
- Maximum pressure* 70 psi (5 bar)
- Temperature Range: 32°F to 104°F (0°C to 40°C)

**To avoid mechanical damage, do not subject the membrane to sudden temperature changes (>1°C/min) or water hammer*

T-Rack® Vario Integrated Module & Rack

AMI Offers Inge T-Rack Vario Racks of Integrated Hollow Fiber UF Membranes in many sizes and configurations. Please contact us with the details of your application for an engineered quotation.

- Integrated module & rack design with integration of feed and drain pipes in module end caps.
- 60% smaller footprint compared to conventional racks.
- Integration of feed and drain pipes in middle
- Modular design enables each T-Rack to be individually configured and tailored to the available floor space. Can be arranged in two or four rows for High flexibility design and no engineering costs.
- Module bodies and filtrate headers with filtrate connections; No O-Rings. Provides high operating reliability.
- All headers have the same nominal diameter and all flange connections are mounted at the same level for simple piping layout and lower installation costs.
- Each row can be operated as a separate filtration line.
- Expandable – more modules can be easily installed at a later date.



Visit us on the web for our complete product line and in-depth technical information. www.appliedmembranes.com

APPLIED MEMBRANES INC.®

**ISO 9001:2008
Certified Company**

(760) 727-3711 • FX: (760) 727-4427
sales@appliedmembranes.com

AMI®, APPLIED MEMBRANES INC.®, APPLIED® ARE TRADEMARKS OF APPLIED MEMBRANES, INC. © 2012