

EZ SDI-1™

**Installation and
Operating Manual**

EZ SDI-1™ Automated Silt Density Index Test System Installation and Operating Manual

Copyright 2003

NOTICE

This manual is protected by federal copyright laws. It should not be copied in any way, shape, or fashion without the written permission.

Version 3.04

**Applied Membranes Inc.
2325 Cousteau Ct.
Vista, CA 92081-8346
760-727-3711**

Version Log

Version	Date	Effective Pages	Description of Changes
3.00	03/12/02	-	Original Issue
3.01	04/09/02	3-5	Heading correction
3.02	04/09/02	-	Corrected Typographical Errors
3.03	09/03/02	-	Added Filter Options
3.04	02/04/03	Appendix A	Analog Output

Conventions and Symbols

Special characters, listed and described below, are used in this documentation to emphasize certain information.



Note: Emphasizes additional information pertinent to the subject matter.



Warning: Emphasizes information about actions, which may result in personal injury.



Caution: Emphasizes information about actions, which may result in equipment damage.

The following electrical symbols may be used in this documentation.

Symbol

Meaning



Direct current.



Alternating current.



Both direct and alternating current.



Earth (ground) terminal.



Frame or chassis terminal.

General Limited Warranty

Warranty

1. In no event will Applied Membranes Inc., or any of its representatives, be responsible or liable for indirect or consequential damages resulting from the use or application of any product. The user and those responsible for applying the product must satisfy themselves with the acceptability of the application.
2. Applied Membranes Inc. extends a one (1) year warranty covering parts and labor on any factory manufactured product. Any product, which is found to have a defect in workmanship or components, shall be replaced or repaired at the option of Applied Membranes Inc.
3. A prepaid minimum inspection fee is required for the repair of products not covered by the warranty period. Contact Applied Membranes Inc. for repair information and repair rates.
4. Applied Membranes Inc. will not be responsible for replacement or repair of any product that was damaged by improper installation, mishandling, or user modifications.
5. All units returned for repair must have a RA (return authorization) number obtained from Applied Membranes Inc. This RA number must be included with the returned product and any correspondence regarding the returned product must reference that number. Shipping on all returned products must be pre-paid and insured. Applied Membranes Inc. will not be responsible for any shipping damage incurred. Repaired products will be shipped pre-paid and insured.
6. Applied Membranes Inc. reserves the right to change any specification or feature of any product at any time. This right also extends to repair fees or any warranty conditions contained herein.

EZ SDI™ Overview	1
Introduction	1-1
Features	1-1
Specifications	1-1
Alarm Outputs	1-2
Operation	1-2
Controls	1-2
Installation	2
Environmental	2-1
Mounting	2-1
Connections	2-1
Ground	2-2
Water	2-2
Alarm Outputs	2-2
Wiring Diagram	2-3
Operation	3
Controls	3-1
Keypad	3-1
LED Indicators	3-2
Test Triggers	3-2
Filter Options	3-2
Test Procedure	3.3
Sequence	3-3
Screens	3-3
Settings	3-5
Settings Table	3-5
Data Logging & SDI Data Reader	3-6
Screen Operation	3-8
Troubleshooting	4
Appendix A	
Analog Output Option	A-1
Notes	

Introduction

The EZ SDI™ Automated Silt Density Index Test System is designed to perform a standard Silt Density Index Test according to the ASTM D194-95. Information is displayed on a back-lit liquid crystal display, and on individual light-emitting diodes (LED). Functions and controls are operated through switches on the membrane keypad.

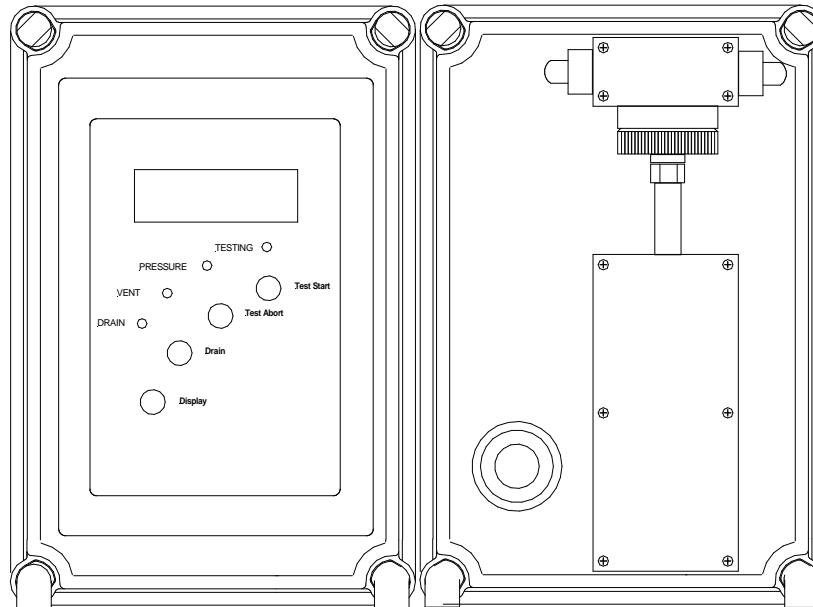

Features

The EZ SDI™ incorporates the following features:

- One Temperature sensor to measure temperature change during test.
- One Pressure sensor to ensure proper filter feed pressure.
- Two Alarm Outputs; one for high or low filter feed pressure, and one for high SDI.

Specifications

The EZ SDI™ incorporates the following specifications:

Power Requirements: The controller requires 120 / 240 volts AC, 50 or 60 Hz, single phase, 1 amp maximum.

Flow Requirements: The controller requires a feed stream with the following conditions:

- 500 mL / Min.
- 70 – 1500 PSI

Tubing connections: The three tubing connections located at the bottom of the enclosure are as follows:

- 1 feed water connection: ¼" Tubing
- 2 vent connections: each are ¼" Tubing Fast & Tite connectors
- 1 drain connection: ¼" I.D. hose barb. The hose is included in the shipment.

The unit will flow 150 mL / Min to the drain at all times when the unit is pressurized. All drain and vent tubing must be routed to an open drain with no restrictions. A valve may be placed on the feed water inlet tubing to prevent excess water flow to waste between tests.



NOTE: If the feed water flow to the EZ SDI™ is interrupted for extended periods between tests, biogrowth may occur in the sample tubing and affect test results.

Environment: The controller can operate at a temperature from 0° to 55° C (32° to 131° F). Relative humidity must not exceed 95 percent.

Alarm Outputs

The EZ SDI™ is equipped with the following alarm outputs. All outputs are in the form of SPST relays rated at 2 Amps, 250 VAC /30 VDC.

Relay # 1: This output is provided as an external alarm indicator. The output is energized when the following alarm conditions are present:

- Low Pressure Filter Feed Pressure
- High Pressure Filter Feed Pressure

Relay # 2: This output is for external alarm indicators. The output is energized when the following alarm conditions are present:

- High Silt Density Index



All outputs are dry contact outputs and do not have internal circuit protection. It is the user's responsibility to provide proper circuit protection on each output.

Operation

The EZ SDI™ has two operating modes, Test and Standby. These are selected from the keypad.

The *test mode* is the operational mode of the system. After installing a new set of filters, the system may be placed into the test mode by means of the TEST START key. The system will remain in the *test mode* until all three SDI tests, SDI5, SDI10 and SDI15, have been completed. The tests may be initiated manually by pressing the TEST Start Key, by a preset timed interval or by an external signal in the form of a dry contact (momentary for at least five seconds).

The *standby mode* is intended to place the system in a temporary non-operational mode. The system will go into the *standby mode* at the completion of the filter test. The unit will display a "RELOAD FILTER" message. The system will stay in *standby mode* until the operator presses the TEST START key.

Controls

The EZ SDI™ is equipped with the following controls and indicators on the front panel of the controller.

- 4 x 20 LCD with LED Backlight
- Four LED Indicators for Alarms and Status
- Four Tactile Keys for Control and Data Entry

Environmental The EZ SDI™ is mounted onto a flat wall or panel surface. The unit should be mounted level both front to back and side-to-side. The EZ SDI™ should not be used in explosive environments. General environmental specifications are listed below.

Environmental Specifications	
Specification	Rating
Storage Temperature	-20 to 70 Deg C
Ambient Operating Temperature	0 to 55 Deg C
Ambient Humidity	30% to 95 % Relative Humidity (Non-Condensing)

Mounting When mounting the EZ SDI™, sufficient room should be allowed on the side and bottom of the device for access to the I/O and sample connections. Mounting dimensions are shown below. Note: Filter changing is easier if the EZ SDI™ is mounted at eye level.

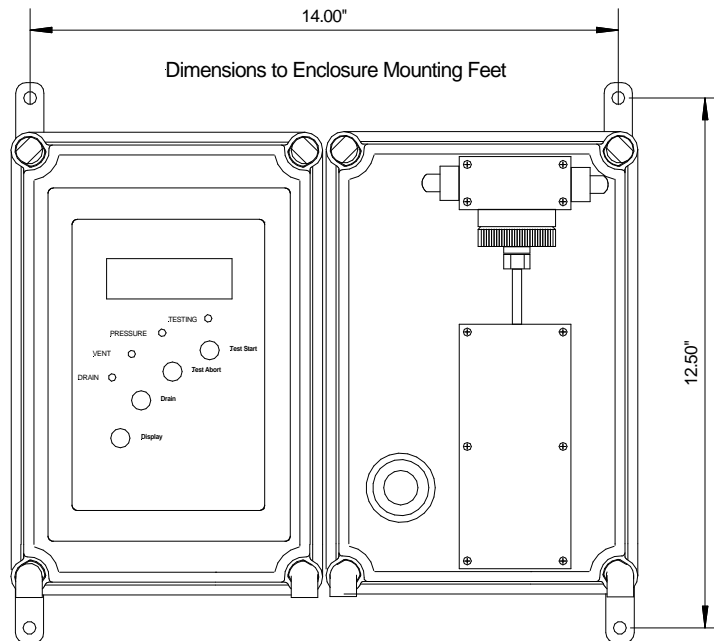

Connections Screw terminals are provided for making connections for alarm outputs. The terminals are numbered in ascending order from bottom to top. A power cord is supplied for standard 120VAC plug-in applications. If the supplied power is to be hardwired to the EZ SDI™ then the power terminals are located on the 24 VDC power supply. (L, N, G). Power should always be disconnected from the EZ SDI™ before making or changing any connections. The EZ SDI™ has internal circuit protection on the solenoid valves and sensors in the form of a panel mounted fuse holder. Only ¼" x 1 ¼" fuses rated at 2 amps should be used.

Ground

A good common ground reference (earth ground) is essential for proper operation of the EZ SDI™. A good earth ground or power circuit ground should be connected to the power supply terminal labeled G. If a power cord is used then the ground terminal on the power cord must be grounded.

Water Connections

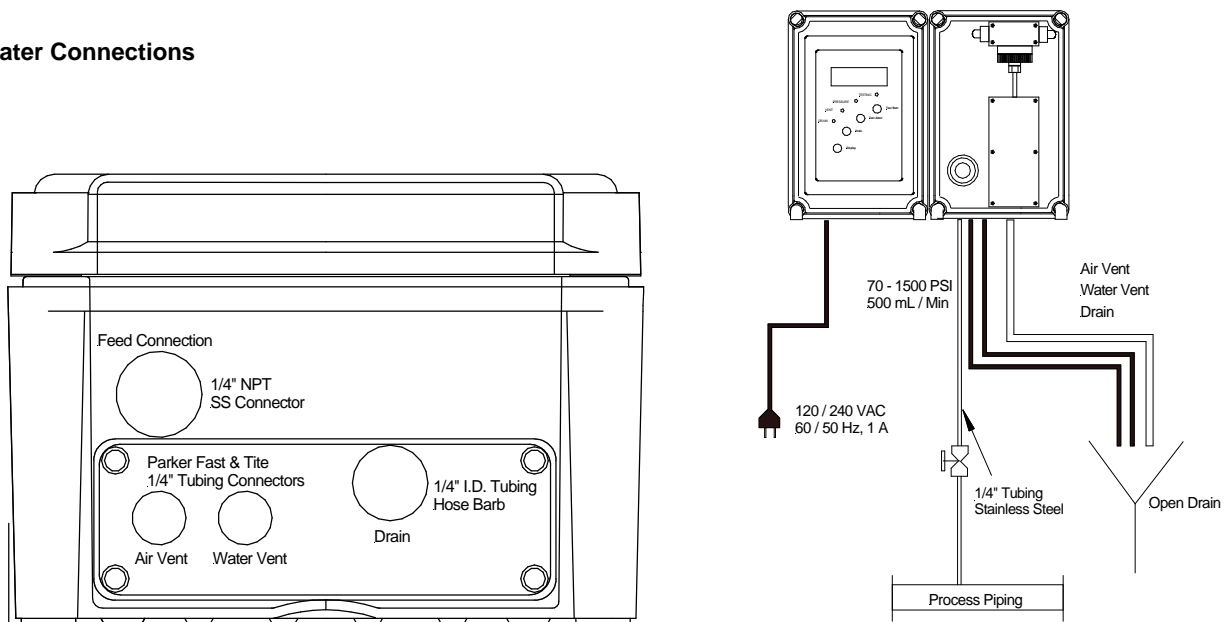

The EZ SDI™ has 4 water connections: one feed, two vents and one drain. The location of each of these connections is shown on the diagram above.

The feed water operating pressure range is 70 – 1500 psi. The feed water connection tubing must be ¼” Stainless Steel. For applications with less than 250 psi feed water ¼” Nylon tubing (Parker part# NB-4-035 or equivalent) can be used. Please consult the manufacturer’s specification for the maximum operating pressure of the proposed Nylon tubing. Connectors for both stainless steel and Nylon tubing are included with the EZ-SDI™. It is the responsibility of the installer to select the proper fittings for their application.



The EZ SDI™ is designed to operate on reverse osmosis feed water. This feed water should be pretreated to remove particles above 160 microns in diameter. The use of feed water with particles over 160 microns in diameter can result in plugging of the regulator or vent orifice. If the regulator or vent orifice becomes plugged then the unit will malfunction and produce invalid results.



Alarm Outputs

All outputs are in the form of SPST relays rated at 2 amps, 240 VAC or 30 VDC. If larger loads are required, use an interposing relay.

The wiring diagram for the output connections is shown at the end of this section.



It is the users responsibility to provide circuit protection on each of the relay outputs.

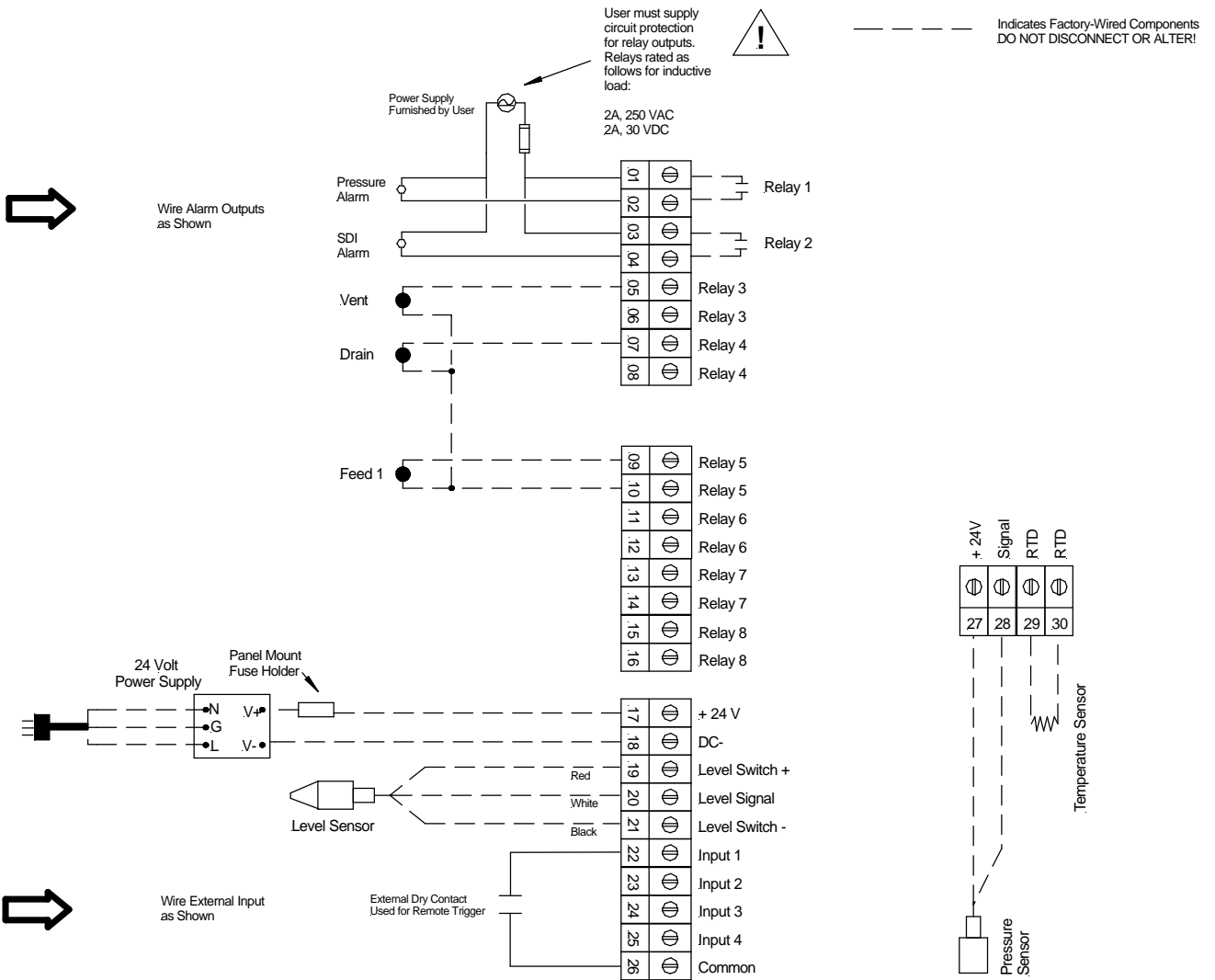

This is an example-wiring diagram for the relay alarm outputs and remote trigger input.

DO NOT DISCONNECT OR ALTER ANY FACTORY WIRING, AS THIS WILL CAUSE THE UNIT TO MALFUNCTION.

Controls

The EZ SDI™ is housed in a NEMA 4 enclosure with a membrane keypad. Indicators include a 4 line x 20 character LCD with LED backlight and four LED indicators for alarm conditions. The major components of the EZ SDI™ are illustrated below.

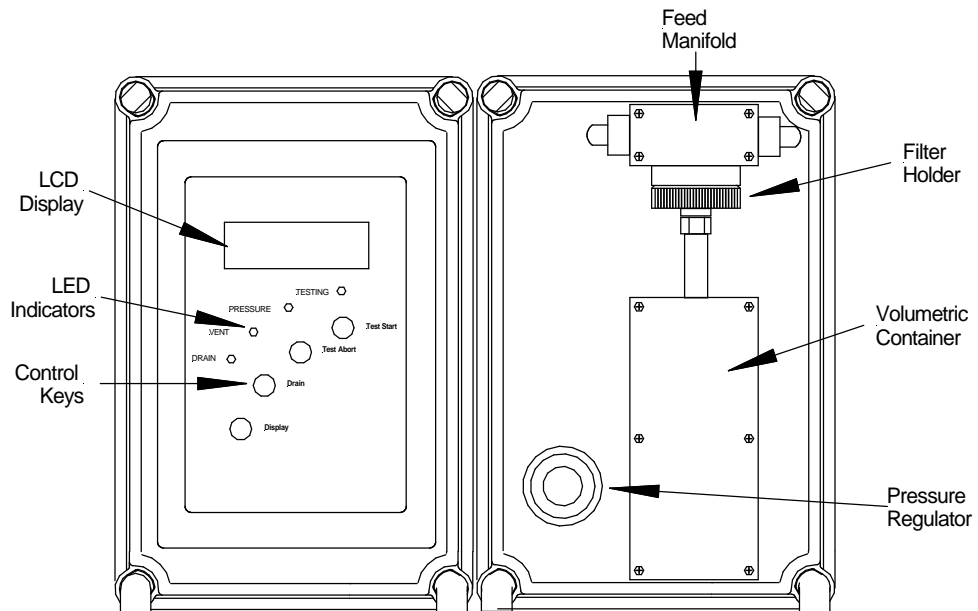

Keypad

The membrane keypad contains 4 tactile keys that are used for a number of control and data entry functions.

Test Start: Pressing this key places the unit in test mode. Depending upon the activation method, a test may start immediately or the unit may display a “Waiting For Trigger “ message. This key is also used as a “down arrow” when one of the Settings Screens is displayed. In the settings screens it is used to decrease the current value of the parameter displayed.

Test Abort: Pressing this key aborts the test in progress, however the unit will remain in test mode until the final test is performed. To reset the unit to the standby position perform a Master Reset (see Test Procedure, page 3-2). A Master Reset can be performed at anytime during the programmed test mode. This key is also used as an “up arrow” when one of the Settings Screens is displayed. In the settings screens it is used to increase the current value of the parameter displayed.

Drain: Pressing this key opens the volumetric chamber drain in the Standby mode. This key is also used as an Enter key when one of the Settings Screens is displayed.

Display: Pressing this key advances the display screen to the next screen. To access the setting screens press and hold this key for 5 seconds. This key is also used when entering the security code in the settings screens. Press the Display key to move to the next digit position when entering the access code.

LED Indicators The four LED indicators are used to indicate status and alarm conditions.

TESTING: A blinking Testing LED indicates that the SDI test is in progress. Once the SDI test has been completed, or if the test is aborted for any reason, the Testing indicator will be continuously illuminated.

PRESSURE: A blinking pressure LED indicates that the pressure is above the high pressure warning set point or below the low pressure warning set point.

VENT: Indicates that the test chamber air vent is open.

DRAIN: Indicates that the volumetric container drain is open.

Test Triggers The SDI test may be triggered by one of three means. These are configured in the Settings screens and are described below.

MANUAL: In this mode, the filter test is initiated by pressing the TEST START key. After the test is completed, the first line of the display will show "RELOAD FILTER".

REMOTE INPUT: In this mode, the filter test is initiated by a dry contact input from a remote device such as a PLC or turbidity meter. The number of input contact closures to initiate the test is adjustable from the Settings screens. For example, the system may be configured to initiate the filter test every five times the contacts close. This may be useful when triggering tests based upon equipment start and stop cycles, filter backwashes, etc. The Status screen shows the number of input signals (contact closures) counted before the initiation of the test. The remote contact input must remain closed for five seconds to be detected. After replacing the filter, the TEST START key must be pressed to place the unit in test mode. The unit will wait for the input trigger before performing the test. After the test is completed, the first line of the display will show "RELOAD FILTER".

TIMER: The timer trigger works in a similar fashion as the Remote Input trigger. After replacing the filter or cartridge, pressing the TEST START key initiates the interval timer (configured in minutes from the Settings screens). At the expiration of this timer the test is initiated. After the test is completed, the first line of the display will show "RELOAD FILTER".

Filter Options The EZ SDI™ is available with one of two filter options: a standard filter holder for a 25 mm flat filter or a disposable 25 mm cartridge. When equipped with a standard filter holder, the lower part of the holder must be unscrewed to disassemble the holder and replace the flat filter. Take care not to lose the O-ring when replacing the filter (NOTE: The O-ring goes on top of the filter). When equipped with the disposable cartridge, simply remove the old cartridge by un-twisting the cartridge from the Luer fitting on the underside of the feed manifold. Re-install the new cartridge by twisting ¾ turn on to the Luer fitting. Do not overtighten!

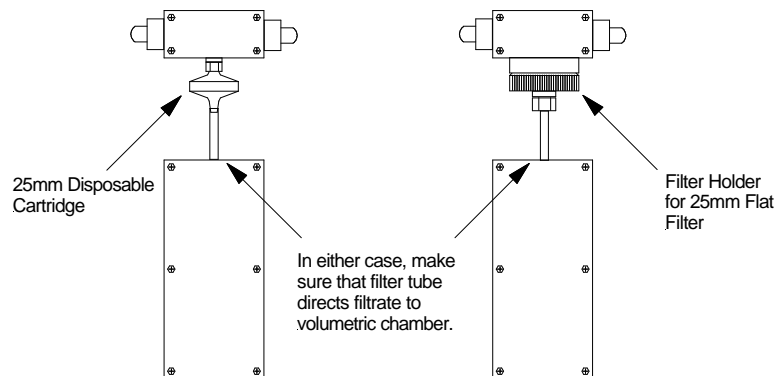

EZ SDI Filter Options

Test Procedure

1. If necessary, perform a Master Reset by first pressing the TEST ABORT key. While holding it down, press the DRAIN key. Release the TEST ABORT key and then release the DRAIN key. On the main screen, the first line of the display will change to "RELOAD FILTERS".
2. Unscrew and remove previously used filter or cartridge from the feed manifold.
3. Replace the filter paper. If a cartridge is used then replace the cartridge by inserting the female end of the Luer connection on the cartridge into the fitting under the feed manifold. Twist the cartridge to ensure a tight seal **but do not over tighten! A ¾ turn is sufficient.**
4. If a valve has been installed in the feed source tubing, make sure that valve is open.
5. Adjust the pressure regulator until the pressure displayed on the LCD display reads 30 psi. NOTE: In low-pressure applications it might be necessary to adjust the pressure reading to slightly above 30 psi in order to maintain 30 psi during the test.
6. Check the water vent drain tubing to ensure a continuous flow is present. NOTE: If a continuous flow is not present then the tubing may have some blockage. The blockage must be removed before starting the test.
7. Press the TEST START key to begin the test sequence. Depending upon the type of trigger selected, the EZ SDI™ may start testing immediately or the system will wait for the appropriate trigger.
8. The LCD will display "TESTING", the Test LED will blink and the testing will begin.
9. If at any time during the test the system automatically aborts the test, look at the main screen to determine the cause. Refer to the troubleshooting section of this manual to review possible solutions.

Sequence

The normal testing sequence is listed below. This sequence is initiated when the appropriate trigger is activated. The test will not be interrupted unless the TEST ABORT key is pressed, an alarm occurs or the test is completed.

Start Test

Open Drain Valve wait 10 seconds.

Close Drain Valve and open both Vent and Feed Valves wait 2 seconds.

Close Vent Valve

When volumetric container is full then open the Drain Valve.

Wait for 300 seconds then close Drain Valve.

When volumetric container is full then open the Drain Valve.

Wait for 300 seconds then close Drain Valve

When volumetric container is full then open the Drain Valve.

Wait for 300 seconds then close Drain Valve

When volumetric container is full then open the Drain Valve.

Test Complete

Note: If the change in temperature during a test is greater than 1.0°C the results should be discarded. For each degree of temperature change the flow through the filter changes approximately 3%.

Screens

The EZ SDI™ displays data and operating status by means of a number of screens displayed on the LCD. Specialized screens are also used for entering set points.

The following page contains an illustration of the screen displayed by the EZ SDI™ and instructions on how to maneuver through the settings screens.

Main Screen - The Main Screen displays information regarding the current test and calculated SDI values. The top line indicates the current system status. The next two lines display the last calculated SDI value for SDI5, SDI10 and SDI15. The last line shows the current filter feed pressure and the change in temperature during the last test.

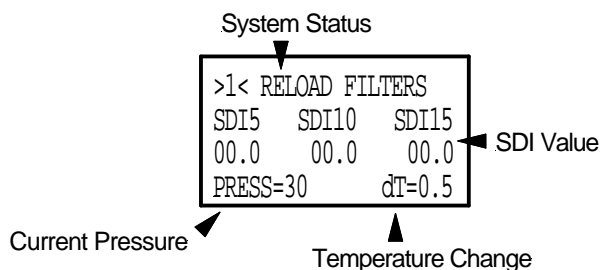

Status Screen - The Status Screen displays information regarding the system status. The top line indicates the current time and date. The next two lines display the archive screen location on which the current test results will be saved. They also display the current and remaining number of input triggers before the test will begin. The last line shows the current test initiation mode and the current temperature.

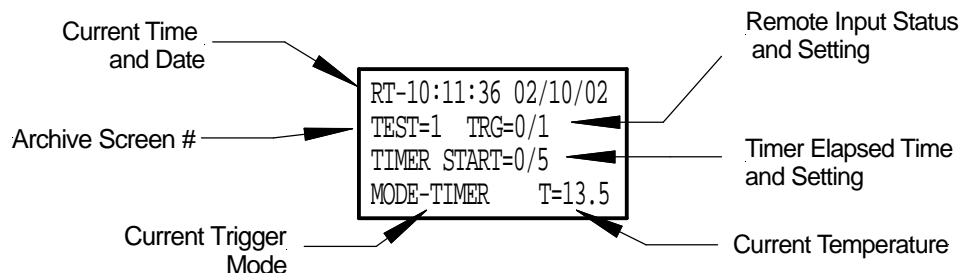

Archive Screen - The 4 Archive Screens display information regarding the previous 4 tests. The top line indicates whether the test passed or failed due to pressure and the change in temperature during the test. The next line displays the time and date that the archived test was started. The last two lines display the SDI Values for the archived test.

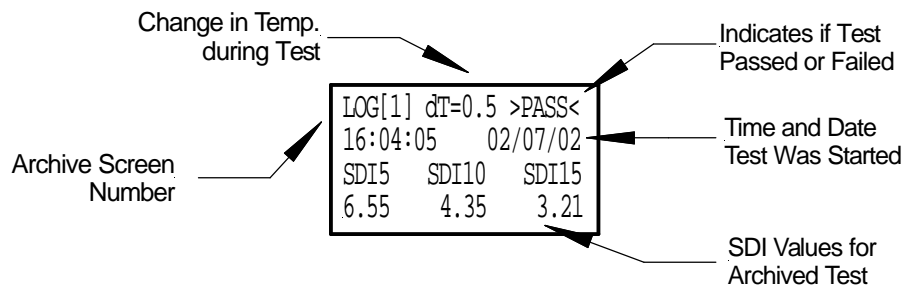

Settings

Settings screens - in the EZ SDI™ are accessed by pressing and holding the Display key for five seconds. The user will be required to enter a four-digit access code to use the Settings screens. See the following page for instructions on entering the access code (default code is 1111). Upon entering the Settings data entry screens, the user may scroll through the settings by repeatedly pressing the Display key. Once in the Settings screens, the user may return to the Data screens by pressing the Display key for six seconds.



Settings may be changed only when the system is in Standby.

Settings Table

The table below lists all of the settings that may be changed in the EZ SDI™. Each setting is identified with an index number.

EZ SDI™ Settings				
Index	Abbreviation	Full Name	Format	Details
0	Test Interval (min)	Interval Between Tests in Timer Trigger Mode	00	Enter the number of minutes desired before the filter test starts, when in timer trigger mode.
1	Trigger 0=M 1=I 2=T	Trigger Mode	0	Use this setting to select the trigger mode. Enter 0 for Manual, 1 for Remote Input, 2 for Timer
2	Trigger Counter	Trigger Counter	00	Enter the number of times the remote input must contact in order to start the next filter test. Used only in Remote Input trigger mode.
3	Clock Hrs	Clock Hours	00	Enter current clock hours 0-23.
4	Clock Min	Clock Minutes	00	Enter current clock minutes 0-59.
5	Clock Sec	Clock Seconds	00	Enter clock seconds 0-59.
6	Clock Month	Clock Month	00	Enter clock month 1-12.
7	Clock Date	Clock Date	00	Enter clock date 1-31.
8	Clock Year	Clock Year	00	Enter clock year (i.e., 02).
9	Temp Zero	Temperature Zero Calibration	000	DO NOT CHANGE THIS SETTING , as it may invalidate the accuracy of the test. Contact Applied Membranes for information on changing this setting.
10	Temp Factor	Temperature Calibration Factor	000	DO NOT CHANGE THIS SETTING , as it may invalidate the accuracy of the test. Contact Applied Membranes for information on changing this setting.
11	Pressure Zero	Pressure Zero Calibration	000	DO NOT CHANGE THIS SETTING , as it may invalidate the accuracy of the test. Contact Applied Membranes for information on changing this setting.

12	Pressure Factor	Pressure Calibration Factor	000	DO NOT CHANGE THIS SETTING , as it may invalidate the accuracy of the test. Contact Applied Membranes for information on changing this setting.
13	Lo Press Warn	Low Pressure Warning set point	000	Pressure set point (in PSI), which activates the low pressure warning LED.
14	Hi Press Warn	High Pressure Set Point	000	Pressure set point (in PSI), which activates the high pressure warning LED.
15	Max Lo Press	Low Pressure Alarm Set Point	000	Pressure set point (in PSI), which activates the low-pressure alarm and aborts the test.
16	Max Hi Press	High Pressure Alarm Set Point	000	Pressure set point (in PSI), which activates the high-pressure alarm and aborts the test.
17	Max SDI 15	High SDI Alarm Set Point	0.00	SDI set point (in hundredths), which activates the High SDI alarm and aborts the test.
18	Access Code 1	Access Code 1	0	Allows the user to change the first digit of the access code.
19	Access Code 2	Access Code 2	0	Allows the user to change the second digit of the access code.
20	Access Code 3	Access Code 3	0	Allows the user to change the third digit of the access code.
21	Access Code 4	Access Code 4	0	Allows the user to change the fourth digit of the access code.

Data Logging

Data Logging Features – The EZ SDI™ will store test results for 64 tests, however, the unit will display only the last 4 test results. The last four test results can be viewed in the archive screens. Use the SDI Data Reader program to view and use the logged SDI Data.

To use the SDI Data Reader Program you will need:

- The serial cable provided with the unit to connect the SDI unit to a PC.
- A PC running Windows 9.x or higher with an available 9 pin serial port connection.

The program can be run from the floppy drive or it can be copied to the user's hard-drive. Follow the steps below to download and use the logged SDI data.

1. Connect the serial cable to the PC and the EZ SDI™
2. Start the SDI Data Reader Program.
3. Select the COM port associated with the 9-pin serial connector.
4. Click on the download icon to download the SDI data. 

The program will download the data and print it to the screen.

If this does not happen, then the COM port configuration is not correct. Re-configure the COM port by selecting a different COM port. Repeat these

steps until the program communicates with the EZ SDI™ or you have tried every available COM port.

5. To print the SDI data click on the printer icon. 

6. To save the file as a comma separated file to be used in a spreadsheet program such as Excel, click on the CSV icon. 

Figure 3-1. EZ-SDI Screen Operation



Troubleshooting Guide

The following table lists the problems commonly encountered when using the SDI. Please examine the table to identify the cause and correction of your problem. If your problem is not listed or the corrective action does not remedy the problem, call Applied Membranes at 760-727-3711.

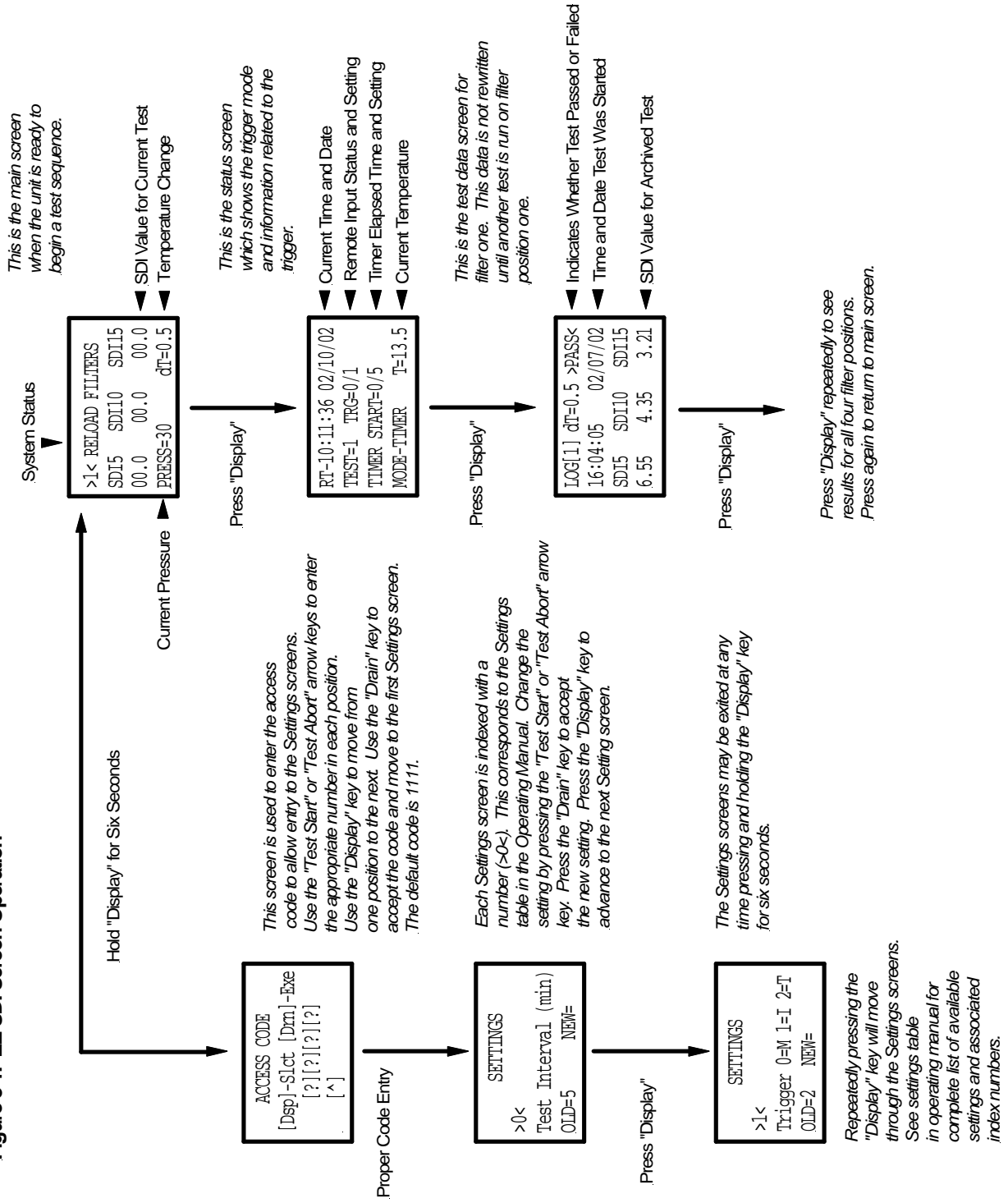
Problem	Probable Cause	Corrective Action
Nothing appears on the display and backlight is not illuminated.	No power.	Ensure that 120 / 240 VAC is connected to the proper terminals on the terminal strip.
		Check condition of fuse in the EZ SDI™ fuse holder.
Display does not respond to keypad entries.	Wrong screen on display.	Some keypad entries only function on certain screens (i.e., Arrow keys do not function on all displays.)
	Damaged keypad.	Contact Applied Membranes.
SDI test aborts before test is complete.	SDI too High.	Check pretreatment equipment for proper operation.
	Feed Pressure too Low.	Verify that feed pressure to SDI unit is at least 50 PSI. A booster pump may be required if feed pressure cannot be maintained above 50 PSI.
	Feed Pressure too High	Verify that the outlet pressure from the regulator is 30 psi. If regulator will not maintain 30 psi or the pressure sensor reads 50 PSI continuously Contact Applied Membranes for replacement.
EZ SDI™ alarms do not activate or false alarms are activated.	Set points not set properly.	Verify correct settings have been entered in the proper Settings screens.
	Loose wire connection on pressure and temperature sensors.	Verify that all input and output wires are properly connected and secure. DO NOT DISCONNECT ANY WIRING WITHIN THE SDI UNIT, AS THE UNIT WILL NOT OPERATE PROPERLY.
Erratic pressure or temperature readings.	Bad connection on sensor cable.	Tighten connections.
	Air or debris trapped in piping.	Mount EZ SDI™ unit according to specifications. Ensure that the proper feed pressure and volume is available. Check the 100-micron inline screen in the feed fitting for blockage.
Temperature readings show full scale.	Open circuit in temperature sensor.	Tighten connections or contact Applied Membranes for replacement probe.

Test starts but water does not flow through filter.	Plugged pressure regulator	Reverse the flow through the regulator. Contact Applied Membranes.
	Malfunction of feed solenoid	Make sure wiring connections are tight. Contact Applied Membranes.
	Wrong filter material	Use only approved 0.45-micron filter papers.
	Feed source is turn OFF	Make sure that the feed source is pressurized. Open the feed isolation valve (if installed).
Air gets trapped on filter surface	Malfunction of vent solenoid valve	Make sure wiring connections are tight. Contact Applied Membranes.
	Vent orifice is plugged	Reverse the flow through the air vent. Contact Applied Membranes.
Test stops but water continues to flow through filter	Malfunction of feed solenoid	Make sure wiring connections are tight. Contact Applied Membranes.
Volumetric chamber never fills	Malfunction of drain solenoid	Make sure wiring connections are tight. Contact Applied Membranes.
Volumetric chamber overflows	Malfunction of drain solenoid	Make sure wiring connections are tight. Contact Applied Membranes.
	Level sensor dirty	Clean level sensor eye with cotton swab or other soft cloth. DO NOT USE A CHEMICAL CLEANER on the eye of the sensor as permanent damage to the equipment may occur.
	Drain tube plugged or otherwise restricted	Clean drain tube make sure it flows unrestricted to an open drain
Pressure reading is 50 psi constantly regardless of regulator adjustment	Water vent tubing is plugged or otherwise restricted.	Clean water vent tube including the orifice inside the tube at origination point. When pressurized the water vent tube should flow approximately 150 mL / Min.

Analog Output Option

A

Introduction

The EZ SDI™ is available with an optional analog output board which allows the results of the SDI test to be output as 4-20 mA analog signals. This enables the user to interface the EZ SDI™ with PLCs, DCS systems, or data loggers.

Mounting

The analog output board is installed at the factory and is mounted on top of the main CPU board of the EZ SDI™. Access to the terminal blocks on the CPU board for relay outputs and discrete inputs is gained by means of access holes provided in the analog output board (see Figure A-1).

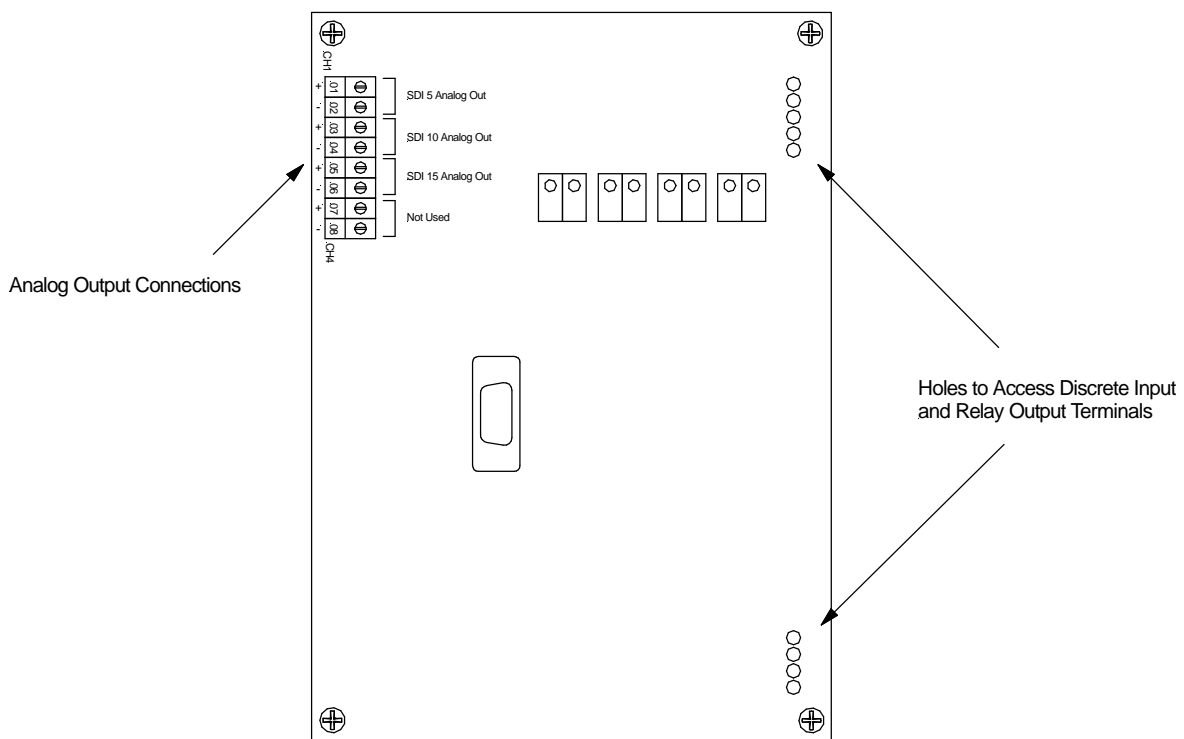

Figure A-1. Overall View of Analog Output Board

Specifications

The EZ SDI™ analog output board incorporates the following specifications:

Power Requirements: The board receives operating power from the CPU board. Each analog output loop must be powered with an external supply (12-36 VDC).

Isolation: Each analog output is isolated from ground, the EZ SDI™ power supply, and the other analog outputs.

Outputs The EZ SDI™ analog output board is equipped with four, 4-20 mA outputs. On the EZ SDI-1™, three of these outputs are used to indicate the results of the SDI₅, SDI₁₀, and SDI₁₅. The fourth output is not used.

Analog Output Channel One – Results of SDI₅, 4-20 mA corresponds to 0-20 SDI units.

Analog Output Channel Two – Results of SDI₁₀, 4-20 mA corresponds to 0-10 SDI units.

Analog Output Channel Three – Results of SDI₁₅, 4-20 mA corresponds to 0-6.7 SDI units.

Operation Upon resetting the EZ SDI™ (for filter replacement), all analog outputs will go to 4 mA. Upon the conclusion of each portion of the test, the corresponding analog channel will output, and hold, the value corresponding to the test result. The value will be held until the unit is reset for the next test. Should the test fail for high SDI or any other reason, the analog output will be set to 20 mA.

Wiring The wiring diagram for the analog outputs is shown in Figure A-2. When wiring the outputs, use shielded cable and always route the cable away from sources of interference (AC wiring, motors, etc.)

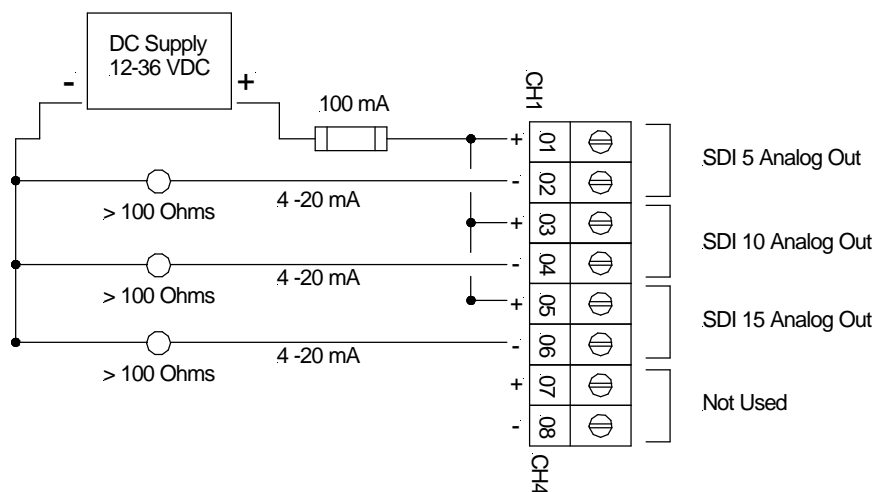

Figure A-2. Analog Loop Wiring

Figure A-2 illustrates the use of a common power supply. Individual power supplies may be used on each output if loop-to-loop isolation is required. Circuit protection in the analog loop(s) should be provided by the user.

Supply Voltage The minimum supply voltage necessary for the analog output loops is a function of the resistance of the corresponding analog input. Figure A-3 illustrates the minimum voltage necessary as a function of input resistance.



IMPORTANT: Each analog output loop should have at least 100 ohms of resistance or damage to the output circuitry may occur.

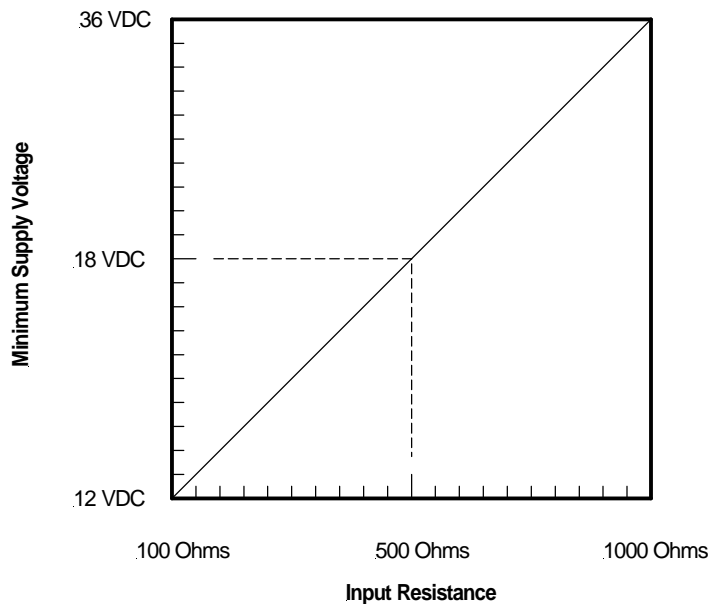

Figure A-3. Minimum Supply Voltage vs. Input Resistance

NOTES:
