

AA Series Systems
MANUAL FOR
OPERATION AND MAINTENANCE
OF
REVERSE OSMOSIS SYSTEMS

for Models:

AA-12514, AA-12521
AA-32514, AA-22521

2325 Cousteau Ct.
Vista, CA 92081
Phone: (760) 727-3711
Fax: (760) 727-4427

Email: Sales@AppliedMembranes.com
Web: <http://www.AppliedMembranes.com>

TABLE OF CONTENTS

<u>ITEM</u>	<u>PAGE</u>
Record Sheet	2
General Information and Safety	3
System Specifications	4
System Operating Conditions	5
System Flow Schematic	6
Component Identification	7
System Installation	8-9
Initial System Start-Up	10
Shut Down	11
Adjustment of Pressure Switches	12
Maintenance Tips	13
Cleaning	14-18
Replacing Membranes	19
Replacing Pre-filters	20
Temperature Correction	21
Operating Do's and Don'ts	22
System Operating Log	23
Troubleshooting	24
Electrical Drawing	25
Component Identification	26
Warranty	27

Fill In the Following Information for Your Records:

Date of purchase: _____

Customer's name: _____

Model number: _____

Serial number: _____

NEVER OPERATE THIS SYSTEM UNTIL THE USER FULLY UNDERSTANDS THE CONTENTS OF THIS MANUAL. FOR OWNERS WHO DO NOT OPERATE THIS EQUIPMENT, IT IS THEIR RESPONSIBILITY THAT THE USER HAS BEEN PROPERLY INSTRUCTED AND FULLY AWARE OF THE MANUAL CONTENTS. THIS IS IMPORTANT IN THE SAFE HANDLING AND IN OBTAINING AN EFFICIENT OPERATION OF THE MACHINE.

IMPORTANT

**Please retain this manual for future reference.
Please read this manual in its entirety before using this machine.**

DISCLAIMER

The information contained in this manual is subject to change without notice.

Applied Membranes, Inc. shall not be liable for technical or editorial omissions made herein; nor for incidental or consequential damages resulting from the furnishing, performance, or use of this material.

GENERAL INFORMATION and SAFETY

READ THIS MANUAL: Prior to operating or servicing this unit, this manual must be read and understood. If anything is not clear, call for assistance before proceeding. Keep this and other associated manuals for future reference and for new operators or qualified service personnel.

USE PROPER POWER CONNECTIONS: Use proper wiring and connection methods to satisfy local electrical codes.

SHOCK HAZARD: Connect this unit to a properly grounded connection in accordance with the National Electrical Code. **DO NOT**, under any circumstances, remove the ground wire or ground prong from any power plug. Do not use extension cords or an adapter without proper consideration.

WARNING: Unplug the system prior to servicing.

WARNING: Do not make any alteration or modification in the wiring or plumbing of the system. This can result in damage to the system and cause injury to operators or users.

WARNING: Flush the system for 30 minutes before use to remove all chemicals present.

CAUTION: Chlorine can damage the membrane. Chlorine should be removed from the feed stream before entering the system. The feed stream should be tested for chlorine at least once a week. Always follow proper maintenance procedures.

CAUTION: Never let the system freeze. Freezing can damage the membrane and plumbing.

SYSTEM SPECIFICATIONS

Electrical

Model	HZ	Motor HP	Volts	Phase
AA-12514-116	60	1/3	115/230	1
AA-12514-215/6	60 or 50	1/3	220/230	1
AA-12521-116	60	1/3	115/230	1
AA-12521-215/6	60 or 50	1/3	220/230	1
AA-32514-116	60	1/3	115/230	1
AA-32514-215/6	60 or 50	1/3	220/230	1
AA-22521-116	60	1/3	115/230	1
AA-22521-215/6	60 or 50	1/3	220/230	1

NOTES:

1. All systems rated at 77 Degrees Fahrenheit (25 Degrees Celsius) using 1000 ppm sodium chloride (NaCl) solution. System capacity decreases significantly with decrease in feed water temperature (see temperature correction chart).
2. Chlorine requirements for the feed water are as follows:

Thin-Film (standard)	0 ppm
CA (special order only)	0.1 ppm Minimum
3. Feed water must be filtered to a turbidity of less than 1 NTU.
4. System recovery (permeate to concentrate ratio) must be maintained at the recommended level. A higher than recommended recovery will lead to a premature fouling of the membrane with a loss of permeate flow and permeate quality.
5. Softened water should be used for the feed water to the RO system.

AA Spec Sheet

MODEL	AA-12514	AA-12521	AA-32514	AA-22521
Rated Capacity, Permeate*				
- Gal/Day	220	350	525	700
- Gals/Hr	9	15	22	29
- Liters/Hr	34	57	83	110
Concentrate Flow (Reject)				
- Gal/Hr	41	65	78	71
- Liters/Hr	155	246	295	269
Permeate: Conc. Flow ratio	1:4.5	1:4.3	1:3.5	1:2.44
System Pressure, PSI	150-200	150-200	150-200	150-200
Design Temperature,				
- Degrees Celsius/ Degrees F	25/77	25/77	25/77	25/77
Sediment Cartridge				
- Replacement **	Monthly	Monthly	Monthly	Monthly
Carbon Cartridge, Pre-membrane				
- Replacement*** (for chlorine removal):	Monthly	Monthly	Monthly	Monthly
Carbon Cartridge, Post-membrane				
- Replacement (for taste/odor polishing):	6 Months	6 Months	6 Months	6 Months
Pressure Switch Settings:				
- Low Pressure (for pump protection):	12 PSI	12 PSI	12 PSI	12 PSI
- Tank Pressure (to shut-off system at tank full):	20/40 PSI	20/40 PSI	20/40 PSI	20/40 PSI

Pretreatment Notations:

(Additional pretreatment equipment is available from Applied Membranes, Inc.)

* Softened feed water is recommended.

** Depends on the turbidity of the feed water. For water with high turbidity an additional back-washable multi-media system may be required to help to minimize cartridge replacements.

*** An additional back-washable pre-carbon system may be required to help to minimize cartridge replacements.

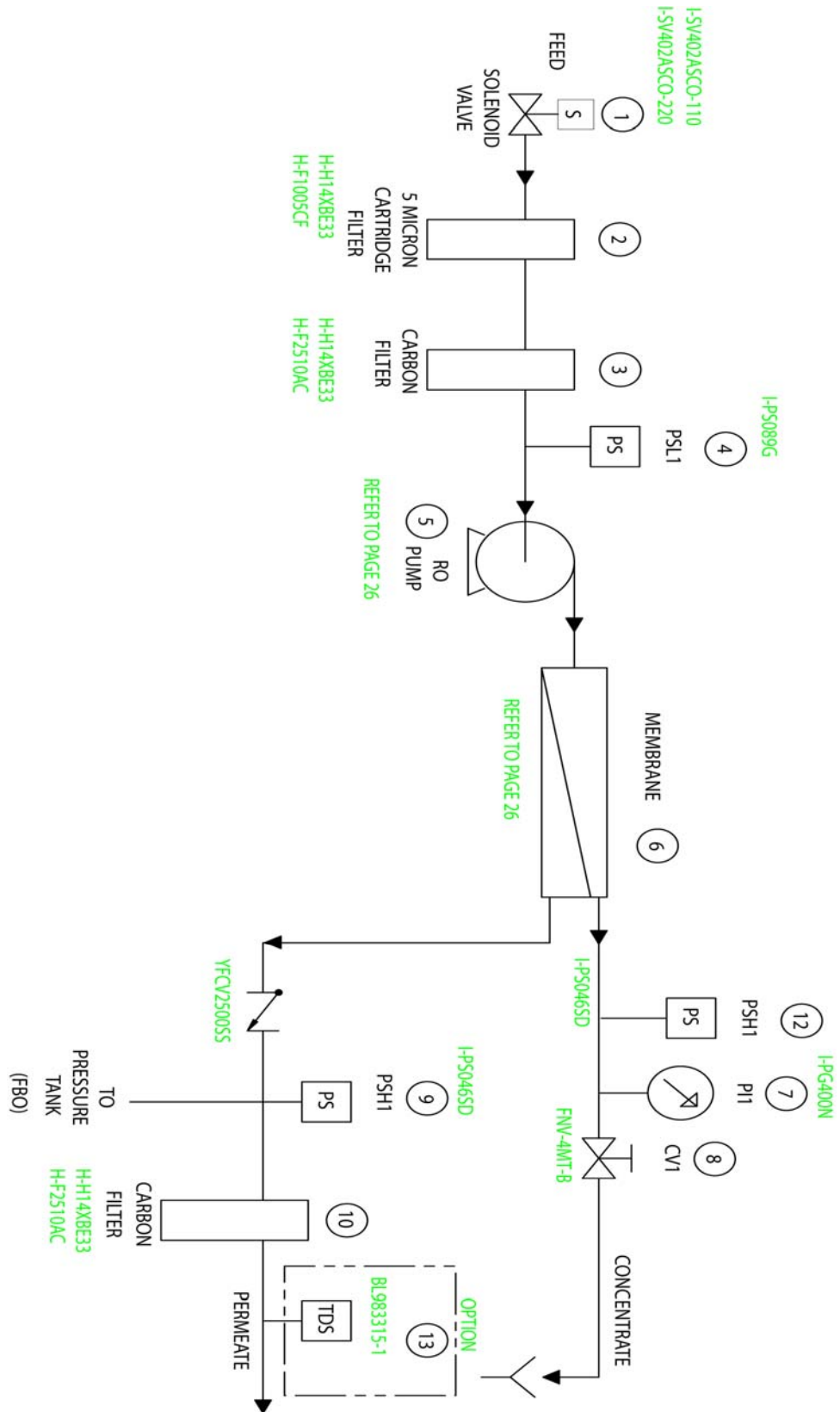

COMPONENT IDENTIFICATION

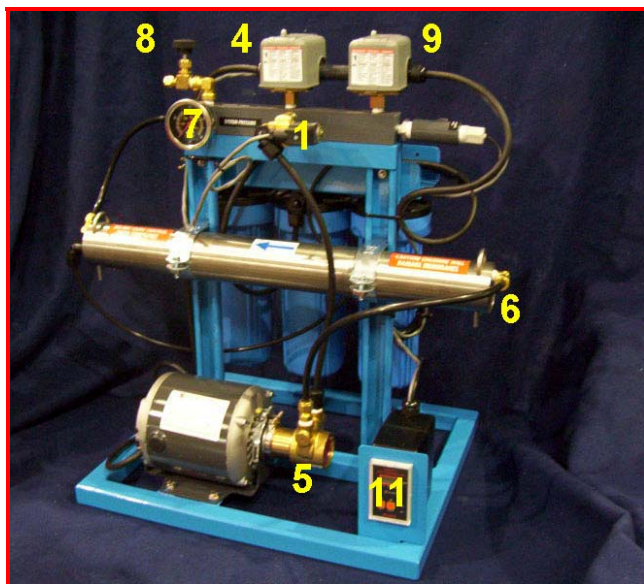

AA System Component Diagram

#	Item	Description
1.	Solenoid Valve	Normally closed. Opens when there is sufficient feed pressure
2.	Cartridge Filter	5 micron sediment filter.
3.	Carbon Filter	Extruded carbon cartridge to remove chlorine from the feed stream.
4.	Low Pressure Switch	Shuts the system down if the inlet pressure is lower than 12 psi (adjustable).
5.	High Pressure Pump	Rotary Vane pump to pressurize the incoming water to 150-200 psi.
6.	Membrane Modules	Membrane elements housed in stainless steel pressure tubes. Membranes require proper flow and pressure for good operation.
7.	System Pressure Gauge	Measures the pressure at the exit end of the membrane modules.
8.	Control Valve	To adjust system pressure. Must not be completely closed when the system is in operation.
9.	Tank Pressure Switch	Turns system on/off based on pressurized storage tank level.
10.	Carbon Filter	Extruded carbon cartridge to remove taste and odor from the permeate stream.
11.	TDS Monitor (optional)	Monitors the permeate quality.

REVERSE OSMOSIS SYSTEM INSTALLATION

1. Locate R.O. system with adequate clearance from walls and other equipment to enable membrane servicing.

2. Run four polyvinyl tube lines to the system as follows:

Line #1: Bring raw water supply feed to the inlet of the first prefilter housing. The line size should be 3/8" . Install a valve in this line. The valve opening should not restrict the water flow.

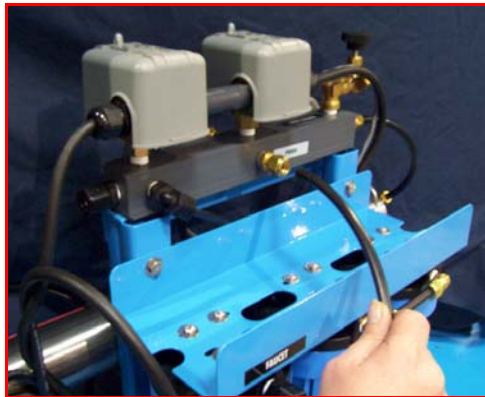

CAUTION: Pump and system performance will be adversely affected if the suction line is restricted.

Line #2: Run a 1/4" line from the open end of the control valve to a drain. Insure that no liquids from other lines in the plant flow back through this line.



Line #3: Run a 3/8" line from the permeate outlet located at right end of PVC manifold to a pressurized storage tank.

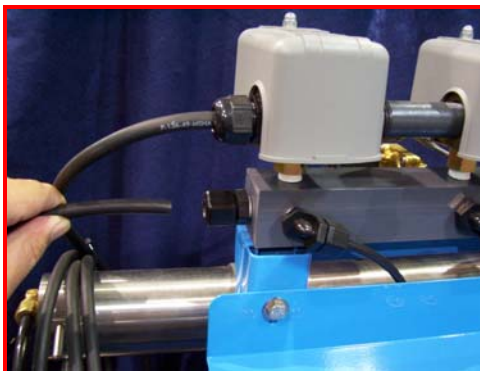

Line #4: Run a 3/8" line from the permeate outlet of the post-filter housing to a faucet or other final permeate destination.

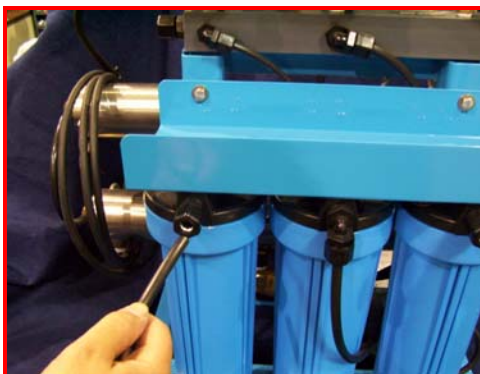

CAUTION: Be sure that all lines are connected before plugging in unit power.

INITIAL SYSTEM START-UP

SYSTEM FLUSH: Direct permeate discharge to drain for first 30 minutes of operation.

1. Connect the system to the appropriate electrical outlet, 110vac or 220vac 1 phase. The solenoid will open as soon the power is applied and the unit will come on if the feed pressure is high enough. **NOTE: Follow all NEC and local electrical codes.**
2. After water is flowing from the concentrate line, adjust the control valve to obtain 150 PSI on the system pressure gauge.
3. Allow the unit to run for 30 minutes.
4. After the flush time is over, turn the unit off by disconnecting the power.
5. Redirect the permeate to the desired location.
6. Turn the power back on. After the pump starts, adjust the control valve to the desired pressure (not to exceed 150 psi). The recycle valve may now be adjusted and the control and recycle valves used to set the system pressure and flows.



CAUTION: To prevent concentrate from precipitating and causing irreversible fouling of the R.O. membrane, do not operate the system with the control valve completely closed. **Do not** exceed recommended maximum recovery.

SHUTDOWN

1. Cut off feed water supply and/or unplug unit.
2. If the unit is to be shut down for more than 1 week, a membrane preservative should be used (**AMI Model No. AM-88**). The preservative can be injected into the system by using a tank and recirculation pump. Close "Control" valve after injection to hold the preservative in the pressure vessel.
3. When the system is restarted after an extended shutdown, follow initial system start up procedures.

SYSTEM MONITORING AND RECORD KEEPING

The system should be monitored and all pertinent data recorded on a daily basis. Data is needed to determine operating efficiency and for performing system maintenance. The latter includes cleaning of the membranes, adjusting the operating conditions, replacement of membranes, and antiscalant use.

ADJUSTMENT OF PRESSURE SWITCHES

Tools Required:

Flat Blade Screw Driver

CAUTION: 115 VOLT SHOCK HAZARD

Turn off R.O. unit and disconnect all electrical power prior to removing cover plates on pressure switches.

LOW & HIGH PRESSURE CUT-OUT SWITCH

1. Loosen nut and remove cover plate.

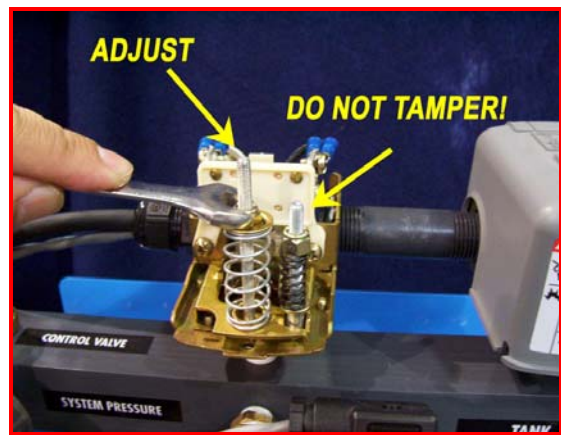

2. Use box wrench to adjust nut on left side 4 to 5 turns counterclockwise; lessen pressure clockwise to raise pressure.
3. Do not tamper with nut on right side.
4. Replace cover.

MAINTENANCE TIPS

MAINTAIN PROPER OPERATING CONDITIONS

Do not exceed 200psi on the pressure gauge. Do not over use recycle flow. This can cause premature scaling of the membrane. A proper concentrate flow is required for a long membrane life.

Test the water from your carbon filter once a week for chlorine break through.

WHEN TO CHANGE CARTRIDGE FILTERS

Cartridge filters should be changed regularly to maintain proper pump pressure and flow.

WHEN TO CLEAN MEMBRANES

In normal operation, the membrane in reverse osmosis elements can become fouled by mineral scale, biological matter, and grime. These deposits build up during operation until they cause loss in water output or loss of salt rejection, or both. Elements should be cleaned whenever the water output rate drops by 10 percent from its initial flow rate (the flow rate established during the first 24 to 48 hours of operation) or when salt content in the product water rises noticeably.

It should be noted that the water output rate will drop if feed water temperature decreases (about 1-1/2 percent per degrees Fahrenheit). This is normal and does not indicate membrane fouling. A malfunction in the pretreatment, pressure control or pump can cause a drop in feed water delivery pressure, feed water flow, or product water output, or an increase in salt passage. If such adjustments are needed, the element may not require cleaning.

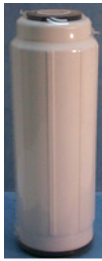

10" Cartridge

Membrane Cleaning and Preservative Cartridges:

- Clean and Preserve Membranes without Removing them from your System
- Reduce Downtime
- Maintain Your System Performance at a Higher Level
- Prolong Membrane Life by Regular Use of Cleaning Cartridges

Ordering Information

--- 10" Standard Cartridges ---		
C-C2510-A11	Scale	TF
C-C2510-A22	Organics	TF

--- 10" Preservative Cartridges ---		
C-C2510-A88	Preservative	TF

Membrane Cleaning in your RO System



10" Cartridge



10" Big Blue Cart.

Membrane Cleaning Cartridges:

- Clean Membranes without Removing them from your System
- Reduce Downtime
- Maintain Your System Performance at a Higher Level
- Prolong Membrane Life by Regular Use of Cleaning Cartridges

How do they Work?

Simply exchange the pre-filter cartridge in your system with a cleaning cartridge. Follow the instructions. Restart the system. You may repeat the process, if required. We recommend a monthly cleaning to obtain optimum results.

To be used in systems up to 20,000 Gallons Per Day

C-C2510-A11

Acidic Cleaning Cartridges for TF Type Membranes

User Instructions

Caution: Handle cartridges carefully.

Cleaning Procedure:

1. Shut down to RO system.
2. Disconnect permeate line and divert to drain before any cleaning cartridge is installed.
3. Remove the filter cartridge from the pre-filter housing.
4. Replace the filter cartridge with the cleaning cartridge and assemble into the filter housing.
5. Turn system ON. After 30-40 seconds*, shut down the system.
6. Let the membrane(s) soak in the cleaning solution overnight.
7. Remove the empty cleaning cartridge and replace it with the original filter.
8. Restart the system. Direct the permeate to drain for 5 minutes.
9. Go back to normal operations.

* Instead of time, you may use one of the following criteria:

- a. Run the system until the pH of the concentrate is almost the same as the cleaning solution (pH=3)
- b. Permeate rate for the system drops to a very low value.

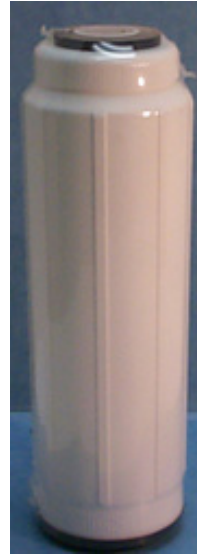

C-C2510-A11



C-C2520-A11

C-C2510A22, C-C2520A22
Alkaline Cleaning Cartridges for TF Type Membranes

User Instructions

Caution: Handle cartridges carefully.

Cleaning Procedure:

1. Shut down the RO system.
2. Disconnect the permeate line and divert permeate to drain during cleaning.
3. Remove the pre-filter cartridge from the filter housing.
4. Replace the sediment pre-filter cartridge with the cleaning cartridge and assemble into the filter housing.
5. Turn system ON. After 30-40 seconds*, shut down the system.
6. Let the membrane(s) soak in the cleaning solution overnight.
7. Remove the empty cleaning cartridge and replace it with the original filter.
8. Restart the system. Direct the permeate to drain for 5 minutes.
9. Go back to normal operations.

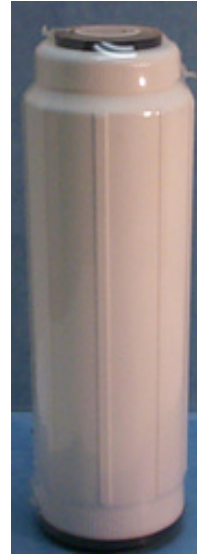

C-C2510-A22



C-C2520-A22

** Instead of time, you may use one of the following criteria:*

- c. Run the system until the pH of the concentrate is almost the same as the cleaning solution (pH=10-12)*
- d. Permeate rate for the system drops to a very low value.*

STORAGE PROTECTION

To prevent bacterial growth and help maintain flux, it is recommended that elements be immersed in AM-88 if the system will be off for more than 3 days.

C-C2510-A88

Membrane Preservative Cartridge

User Instructions

Caution: Handle cartridges carefully .

Preserving Procedure:

1. Shut down to RO system.
2. Disconnect the permeate line and direct permeate to drain during cleaning/preserving.
3. Remove the 5M filter cartridge from the pre-filter housing.
4. Replace the filter cartridge with the preservative cartridge and assemble into the filter housing.
5. Turn system ON. After 30-40 seconds*, shut down the system.
6. Drain the system of the permeate solution as much as possible by opening a valve/fitting at a low point in the system. Close off the inlet and outlet to the membrane/system.

Flushing out Preservative/Re-start Procedure:

7. Open valves etc. and put the system back in the position it was before preserving.
8. Remove the empty preservative cartridge and replace it with a new cartridge filter.
9. Re-start the system. Direct permeate to drain for 15-30 minutes.
10. Go back to normal operation.

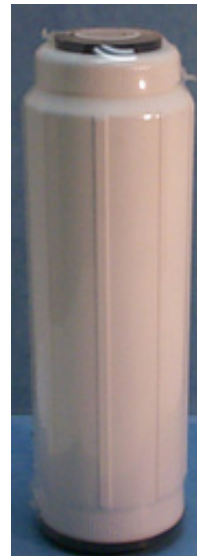

C-C2510-A88



C-C2520-A88

REPLACING MEMBRANES

TOOLS:

- Rubber Mallet
- Flat Blade Screwdriver
- Open End Wrench, 7/8"
- Food Grade RT-111 silicone
- Safety Glasses

PROCEDURE:

1. Turn off the RO system.
2. Relieve pressure on the membrane array.
3. Remove all lines from both ends of the pressure vessel(s). Please make sure that the fittings are marked – so it can go back to the correct locations.
4. **4A.) U-PIN STYLE HOUSINGS:**
Remove u-pins from vessel. Slowly and carefully pull end plugs out from the fitting with a channel lock. Remove end plugs by pulling carefully.



REPLACING PREFILTERS

PROCEDURES

1. Shut unit down.
2. Close inlet supply valve.
3. Turn the blue pressure housings counterclockwise (use filter wrench **AMI Model No. H-C9200** for standard 10" filter housing). Filter cartridge should come free from the housing top and remain in the housing.
4. Remove and replace cartridge.
5. Before replacing housing, insure that o-ring seal is lubed and placed in groove of housing (**AMI Model No. for lubricant: H-C111DC**). Inspect seal and replace as needed.
6. Rotate housing clockwise until hand tight.



1. Sediment Filter – Removes rust and dirt particles
2. Carbon Filter – Removes chlorine
3. Carbon Filter Polishing – Removes bad taste & odor imparted by bladder tank

Temperature Correction

Temperature of the feed water and the net driving pressure across the element must be taken into account before comparing or evaluating the performance of a membrane element or a reverse osmosis system.

Temperature Correction Factor

The water temperature is one of the key factors in the performance of the reverse osmosis membrane element. The higher the temperature, the more the product flow, and vice versa. All reverse osmosis membrane elements and systems are rated at 77° Fahrenheit (25° Celsius). To find the membrane permeate rate at a different temperature, follow these steps:

Find the temperature correction factor (TCF) from the below table. Divide the rated permeate flow at 77° Fahrenheit by the temperature correction factor. The result is the permeate flow at the desired temperature.

EXAMPLE

QUESTION: For a thin-film membrane permeate rated at 1800 gallons per day at 77° Fahrenheit, what is the actual permeate rate at 59° Fahrenheit?

ANSWER: Temperature correction factor (from below table) for 59°F = 1.47

Permeate flow at 59 degrees Fahrenheit = $1800 \div 1.47 = 1224$ gallons/day

Feed Water Temperature		TCF for Thin Film	TCF for CTA/CAB	Feed Water Temperature		TCF for Thin Film	TCF for CTA/CAB
C °	F°			C °	F°		
1	33.8	3.64	2.23	26	78.8	0.97	0.97
2	35.6	3.23	2.15	27	80.6	0.94	0.94
3	37.4	3.03	2.08	28	82.4	0.91	0.91
4	39.2	2.78	2.00	29	84.2	0.88	0.89
5	41	2.58	1.93	30	86	0.85	0.86
6	42.8	2.38	1.87	31	87.8	0.83	0.83
7	44.6	2.22	1.80	32	89.6	0.80	0.81
8	46.4	2.11	1.74	33	91.4	0.77	0.79
9	48.2	2.00	1.68	34	93.2	0.75	0.76
10	50	1.89	1.63	35	95	0.73	0.74
11	51.8	1.78	1.57	36	96.8	0.71	0.72
12	53.6	1.68	1.52	37	98.4	0.69	0.71
13	55.4	1.61	1.47	38	100.4	0.67	0.68
14	57.2	1.54	1.42	39	102.2	0.65	0.66
15	59	1.47	1.38	40	104	0.63	0.65
16	60.8	1.39	1.33	41	105.8	0.61	
17	62.6	1.34	1.29	42	107.6	0.60	
18	64.4	1.29	1.25	43	109.4	0.58	
19	66.2	1.24	1.21	44	111.2	0.56	
20	68	1.19	1.17	45	113	0.54	
21	69.8	1.15	1.13	46	114.8	0.53	
22	71.6	1.11	1.10	47	116.6	0.51	
23	73.4	1.08	1.06	48	118.4	0.49	
24	75.2	1.04	1.03	49	120.2	0.47	
25	77	1.00	1.00	50	122	0.46	

OPERATING DO'S AND DON'TS

DO:

1. Change the cartridge filters regularly.
2. Monitor the system and keep a daily log.
3. Run the system, as much as possible, on a continuous basis.
4. Adjust the system recovery to recommend value.

DON'T:

1. Permit chlorine in the feed water.
2. Shut down the system for extended periods.
3. Close the control valve completely.
4. Operate the system with insufficient feed flow.

SYSTEM OPERATING LOG

DATE							
TIME							
PRESSURE							
WATER TEMP.							
FILTERS 5 MICRON							
PRE CARBON							
POST CARBON							
MEMBRANE CHANGE							
RECORDED BY:							

NOTES:

TROUBLESHOOTING

<u>PROBLEM</u>	<u>POSSIBLE CAUSE</u>	<u>SOLUTION</u>
Inlet pressure low	Low supply pressure	Correct incoming supply pressure
Permeate flow low	Low water temperature	Adjust water temperature
Pump noisy	Low inlet flow	See "Inlet pressure low"
Permeate Quality poor	Low Inlet flow	See above

110/220V
1Ø
50/60HZ

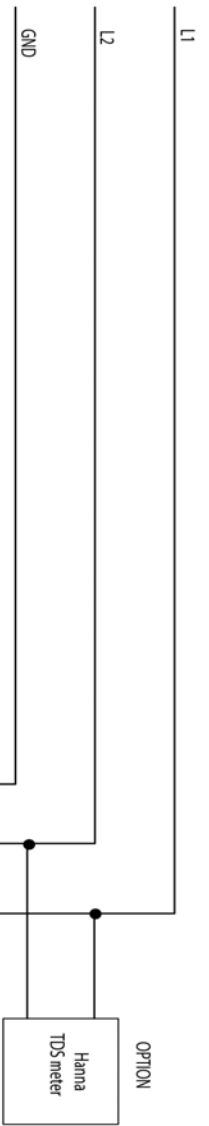

6 FT CORD WITH UNIT INSTALL
125V / 250V 15A PLUG AS
PER SYSTEM VOLTAGE.

FULL LOAD CURRENTS			
HP	115V 1Ø 60HZ	230V 1Ø 60HZ	
1/2	9.8	4.9	
1/3	7.2	4.1	

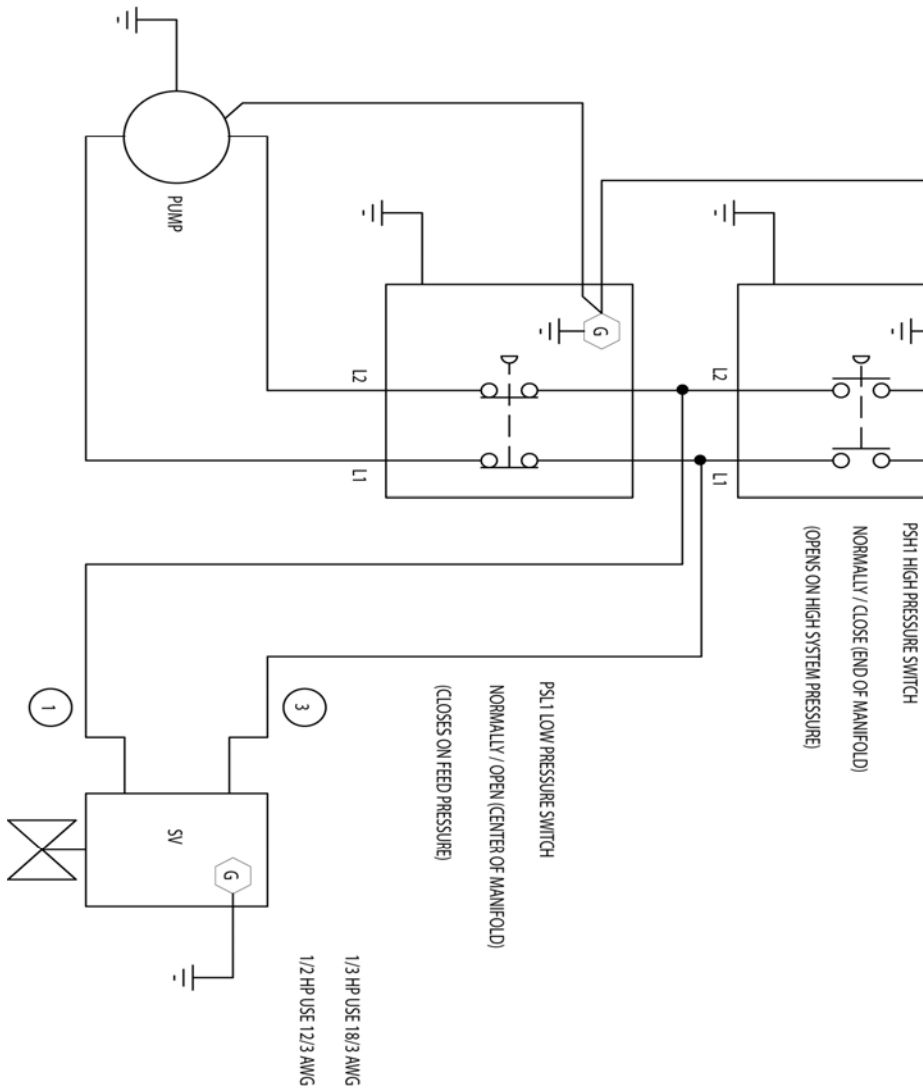

COMPONENT IDENTIFICATION

ITEM	PART NUMBER
Solenoid Valve 3/8"	I-SV402ASCO-110 I-SV402ASCO-220
Low Pressure Switch	I-PS089G
Sediment filter Cartridge 5 Micron	H-F1005CF
Carbon Filter Cartridge 10"	H-F2510AC
Filter Housing 10 inch	H-H14XBE33
High Pressure Pump	
	AA-12514 112A050F11XX
	AA-12521 112A080F11XX
	AA-22521 112B100F11XX
	AA-32514 112B100F11XX
Membrane Element	
	AA-12514 M-T2514ALE
	AA-12521 M-T2521ALE
	AA-22521 M-T2521ALE
	AA-32514 M-T2514ALE
Membrane Housing	
	AA-12514 PV2514SSAU
	AA-12521 PV2521SSAU
	AA-22521 PV2521SSAU
	AA-32514 PV2514SSAU
Pressure Gauge	I-PG400N
Control Valve 1/4"	FNV-4MT-B
Check Valve 1/4"	YFCV2500SS
Motor 1/3 HP (60/50 HZ)	P-MP828
TDS (optional)	BL983315-1
Probe	HI7634

WARRANTY

SELLER hereby warrants to CUSTOMER that the goods herein described will be free from any liens or encumbrances, that good title to said goods will be conveyed to CUSTOMER by sale of same.

SELLER warrants materials of its own manufacture against defects in material and workmanship under normal conditions of usage and service for one year from whichever of the following events occurs first:

- First use in a system.
- Three (3) months following date of shipment from Vista, CA.

Materials not manufactured by seller receive only such warranty, if any, of the manufacturer thereof and which are hereby assigned to CUSTOMER without recourse to SELLER.

SELLER'S obligation under this warranty is limited to and shall be fully discharged by repairing or replacing any defective part FOB its works. SELLER shall not be liable for repair or alterations made without SELLER's prior written approval; for membrane elements becoming plugged by suspended matter, precipitates, or biological growth; or failure to properly maintain the element. SELLER shall not be liable for damages or delays caused by defective material. Elements returned to SELLER for warranty examination must be shipped freight prepaid.

SELLER'S Liability. SELLER SHALL NOT BE LIABLE FOR PROSPECTIVE PROFITS OR SPECIAL, INDIRECT OR CONSEQUENTIAL DAMAGES, NOR SHALL RECOVERY OF ANY KIND AGAINST SELLER BE GREATER IN AMOUNT THAN THE PURCHASE PRICE OF THE SPECIFIC GOODS SOLD AND CAUSING THE ALLEGED DAMAGE, WHETHER SUCH CLAIM BE BASED ON CONTRACT OR TORT; provided, however, the aforesaid to the contrary notwithstanding, SELLER shall not be liable for any bodily injuries or property damage directly caused by its willful, wanton or negligent acts.

All Other Warranties and Damages. THERE ARE NO WARRANTIES ESTABLISHED, EXPRESS OR IMPLIED OR STATUTORY, INCLUDING THE WARRANTY OF MERCHANTABILITY, EXCEPT THOSE SET FORTH ABOVE OR ANY PERFORMANCE WARRANTY WHICH IS ATTACHED TO THIS ORDER.

Permits, Ordinances and Code Compliance. CUSTOMER has full responsibility for obtaining any licenses, permits and inspections required with respect to installation and use of the goods herein described.

Governing Law. Any agreement based upon this Order and the obligations thereby imposed on SELLER and CUSTOMER shall be governed by and construed according to the laws of the State of California.