

# AMI<sup>®</sup> FILTERS — USA —

## Stainless Steel Filter Housings



# APPLIED MEMBRANES INC.<sup>®</sup>

Industry Leader in RO Expertise and Membrane Applications Since 1983<sup>™</sup>



## Stainless Steel Multi-Cartridge Filter Housings

AMI® Stainless Steel Multi-Cartridge Filter Housings provide a high-quality solution for high-volume filtering at reduced pricing. Ideal for use in membrane desalination systems, pre-filtration, high purity water, post-filtration, food & beverage, industrial facilities and similar applications.

### Industry Applications

- Reverse Osmosis Pretreatment
- Chemical & Petrochemical
- Dairy
- Drinking Water
- Food and Beverage
- Liquid Desalination
- Electronics
- Fuel Material Extraction
- Pharmaceuticals & Biotechnology
- Pulp & Paper
- Wastewater Reuse/Recycled Water
- Power Generation
- Industrial Water Treatment



### Features and Specifications

- Band V-Clamp Top Closure for Quick and Easy Cartridge Replacement
- Side-In and Side-Out Connections for Easy Installation and Service
- Built-In Drain and Vent Ports
- Side Ports for Inlet/Outlet Pressure Gauges
- Available with Threaded or Flanged Fittings for Easy Installation
- Housings are Compatible with Industry-Standard Size Filter Cartridges: 2.5" OD in 20", 30", or 40" Lengths
- Materials of Construction:
  - Available in 316L Stainless Steel with Electropolish Finish or in 304 Stainless Steel with Poly Coat Finish.
- Operating Limits:
  - Maximum Operating Pressure: 150 psi (10 bar)
  - Maximum Operating Temperature: 250°F (120°C)



## Stainless Steel Multi-Cartridge Filter Housings

### Design and Ordering Information

AMI® Stainless Steel Filter Housings are designed for use with industry standard 2.5" OD x 20", 30" and 40" Length filter cartridges.

#### 316L Stainless Steel Filter Housings with Electropolish Finish

Model No.	Flow Rate*		Houses Cartridges†		Inlet/ Outlet	Vent	Drain
	gpm	m³/hr	Qty.	Length			
C-0530-2F-316LEP	105	24	5	30"	2" Flange	¼" NPT	½" NPT
C-0730-2F-316LEP	147	33	7	30"	2" Flange	¼" NPT	½" NPT
C-0740-2F-316LEP	196	45	7	40"	2" Flange	¼" NPT	½" NPT
C-1230-3F-316LEP	252	57	12	30"	3" Flange	¼" NPT	½" NPT
C-1240-3F-316LEP	336	76	12	40"	3" Flange	¼" NPT	½" NPT
C-2230-4F-316LEP	462	105	22	30"	4" Flange	¼" NPT	½" NPT
C-2240-4F-316LEP	616	140	22	40"	4" Flange	¼" NPT	½" NPT



#### 304 Stainless Steel Filter Housings with Poly Coat Finish

Model No.	Flow Rate*		Houses Cartridges†		Inlet/ Outlet	Vent	Drain
	gpm	m³/hr	Qty.	Length			
C-0520-2F-304PC	70	16	5	20"	2" Flange	¼" NPT	½" NPT
C-0530-2F-304PC	105	24	5	30"	2" Flange	¼" NPT	½" NPT
C-0540-2F-304PC	140	32	5	40"	2" Flange	¼" NPT	½" NPT
C-0730-2F-304PC	147	33	7	30"	2" Flange	¼" NPT	½" NPT
C-0740-2F-304PC	196	45	7	40"	2" Flange	¼" NPT	½" NPT
C-1230-3F-304PC	252	57	12	30"	3" Flange	¼" NPT	½" NPT
C-1240-3F-304PC	336	76	12	40"	3" Flange	¼" NPT	½" NPT
C-2230-4F-304PC	462	105	22	30"	4" Flange	¼" NPT	½" NPT
C-2240-4F-304PC	616	140	22	40"	4" Flange	¼" NPT	½" NPT



\*Flow rates shown are based on 7 gpm/10" Filter length, 25-micron string wound filter cartridge, and clean water (viscosity cp = 1) at 2psid. Flow rates are for guide lines only. Actual flow rates will vary based on fluid, viscosity, cartridge type, micron ratings and other factors.

†Housing will accept standard 2.5" OD Filter cartridges in the following lengths: 20", 30" (29¼" or 30"), 40" (39" or 40")

## Stainless Steel Multi-Cartridge Filter Housings

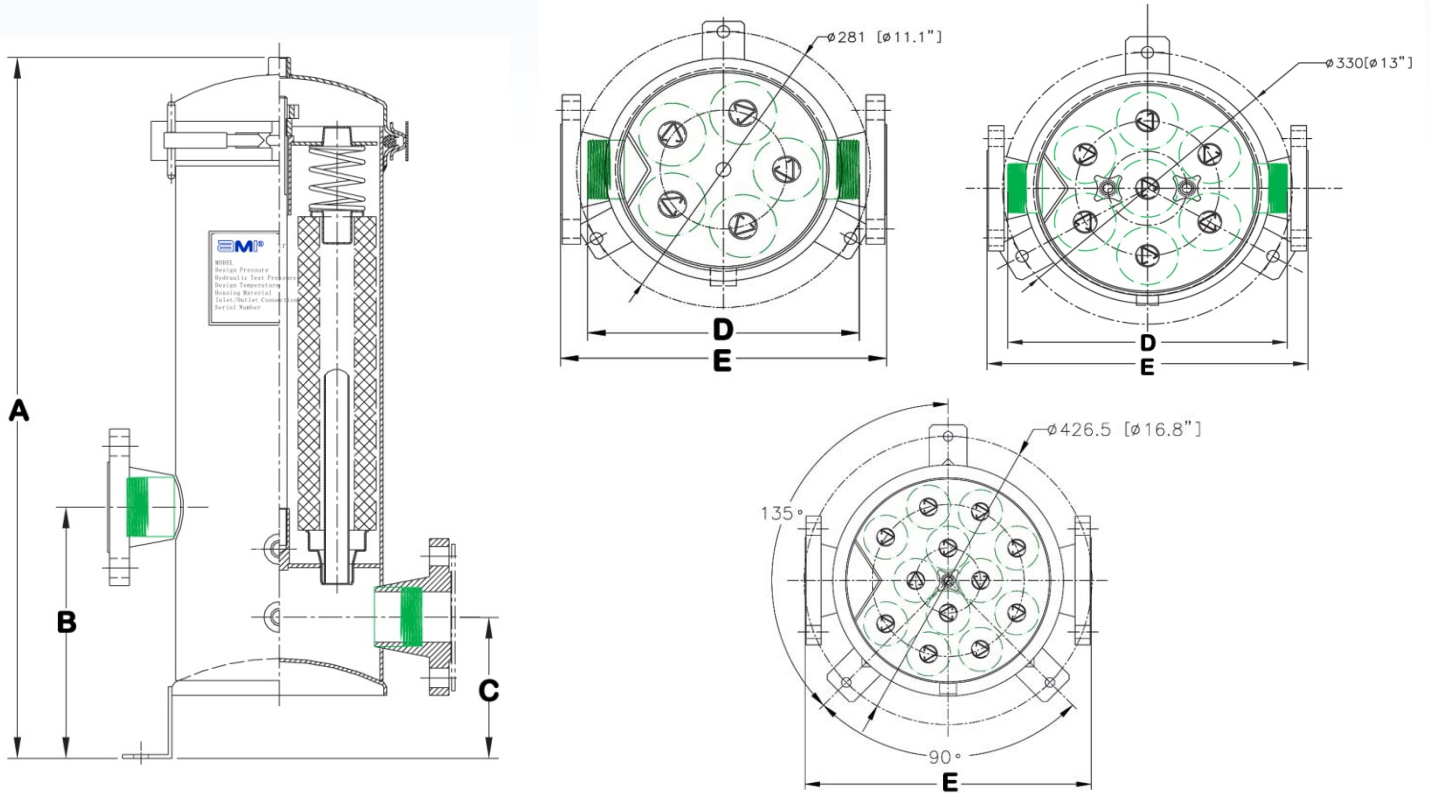

### Installation Dimensions

Model No.	Houses Cartridges		Installation Dimensions									
	Qty.	Length	A		B		C		D		E	
			in	mm	in	mm	in	mm	in	mm	in	mm
C-0520-2F-*	5	20"	33.7	857	9.5	242	5.5	140	10.2	260	12.0	305
C-0530-2F-*	5	30"	43.7	1111	9.5	242	5.5	140	10.2	260	12.0	305
C-0540-2F-*	5	40"	53.7	1365	9.5	242	5.5	140	10.2	260	12.0	305
C-0730-2F-*	7	30"	45.1	1145	10.6	269	5.8	148	12.4	316	14.4	366
C-0740-2F-*	7	40"	55.1	1399	10.6	269	5.8	148	12.8	326	14.6	370
C-1230-3F-*	12	30"	51.3	1303	15.1	384	9.8	248	n/a	n/a	16.7	424
C-1240-3F*	12	40"	61.3	1557	15.1	384	9.8	248	n/a	n/a	16.7	424
C-2230-4F-*	22	30"	52.0	1321	15.2	387	9.5	241	n/a	n/a	21.0	533
C-2240-4F-*	22	40"	62.0	1575	15.2	387	9.5	241	n/a	n/a	21.0	533

Dimensions are approximate for reference only.