



LEAK DETECTION SENSORS (LDS SERIES) TANK LEVEL CONTROLLERS (TLC SERIES)

FLOW CONTROL COMPONENTS

Aquatec's Leak Detection Sensors and Tank Level Controllers allow you to monitor fluid levels using multiple sensors. These sensors are placed either in the projected path of leaking water (LDS Series) or attached to a non-metallic holding tank (TLC Series).

Our LDS Series has been engineered to prevent serious water damage in the event of a system malfunction. Whenever water is detected, the LDS valve closes automatically and the auxiliary output is immediately de-energized.

Our TLC Series utilizes a switch/valve combination which automatically shuts off feed water at a predetermined "full level" and then reopens the integral feed water valve at a second "refill level". The TLC Series provides a switched output to control a pump or other accessory.

Both the TLC and LDS Series are powered by Aquatec's patented, energy saving 24V coil, which operates without heat build-up or AC coil noise. Both products are powerful enough to open against pressures up to 100 PSI. All integrated control circuitry is hermetically sealed for extended life and maximum reliability under severe operating conditions.

These devices can include a modular connector for plug-and-play integration with Aquatec's other system components.

- **Helps prevent costly water-related damage**
- **Provides automatic water shut-off when required**
- **Provides positive level control for vented tanks**
- **Separate output can either stop operation or control secondary device**
- **Hermetically sealed circuitry**

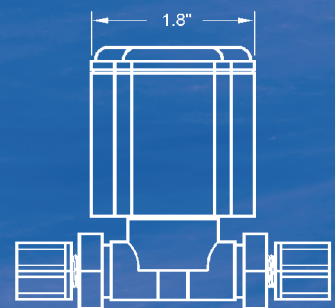
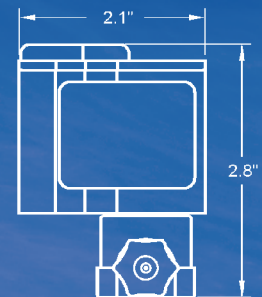

TECHNICAL SPECIFICATIONS:

WETTED MATERIALS:	Polypropylene, EPDM, Stainless Steel (300/400 Series)
POWER REQUIREMENTS:	24 VAC, 50/60 Hz, 130 mA
SWITCHED OUTPUT POWER:	24 VAC, 1 amp
INLET PRESSURE/ORIFICE:	Maximum 100 psi, .093" diameter orifice
STANDARD FITTINGS:	John Guest 1/4" built-in ports, Jaco 1/4" black inlet, 1/4" white outlet
OPTIONAL FITTINGS:	John Guest 3/8" grey
SENSORS/SENSITIVITY:	Stainless Steel, up to 250 kilo-ohms for water with TDS greater than 3 parts per million.
ELECTRICAL CONNECTION:	AMP Mate-N-Lok, custom sensor harness