



DOW™ Ultrafiltration Modules Model SFP-2860

Features

The DOW™ ultrafiltration (UF) modules are made from high strength, hollow fiber membranes that have excellent features and benefits:

- 0.03 μ nominal pore diameter for removal of bacteria, viruses, and particulates including colloids to protect downstream processes such as RO
- PVDF polymeric hollow fibers for high strength and chemical resistance allows long membrane life
- Hydrophilic PVDF fibers for easy cleaning and wettability that help maintain long term performance
- Outside In flow configuration for high tolerance to feed solids that help reduce the need for pretreatment processes
- U-PVC housing, helping to eliminate the need for costly pressure vessels

This module is ideal for systems with capacities greater than 50 m³/hr (220 gpm). The larger, 8 inch diameter module offers the highest effective membrane area of the DOW UF modules, which contributes to a more economical membrane system design. The shorter, 60 inch length module offers higher efficiencies over a wider range of feed water conditions compared to longer length modules.

The DOW Ultrafiltration Modules are used for a wide variety of treatment applications such as surface water, seawater, industrial wastewaters, and secondary effluent wastewater.

Product Specifications

Model	Part Number	Membrane Area		Module Volume		Weight (empty/water filled)	
		m ²	ft ²	liters	gallons	kg	lbs
SFP-2860	280933	51	549	35	9.3	48 / 83	106 / 183

Figure 1

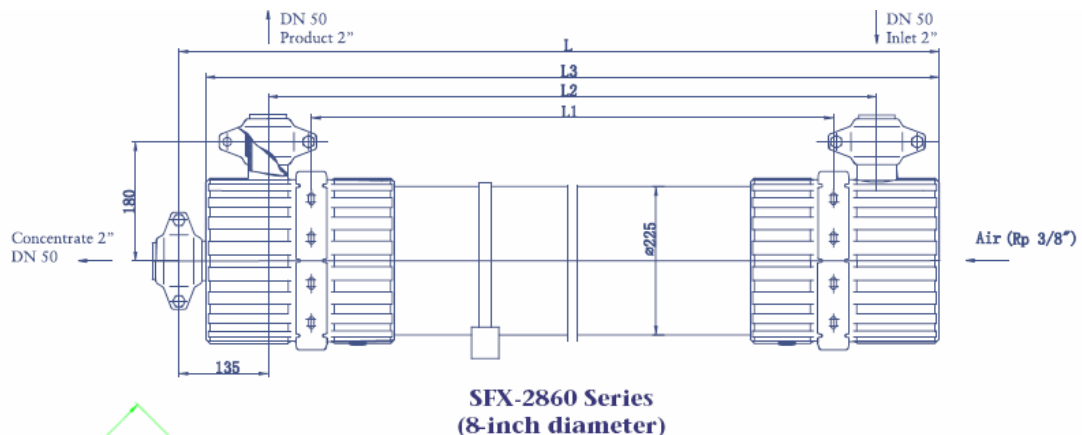
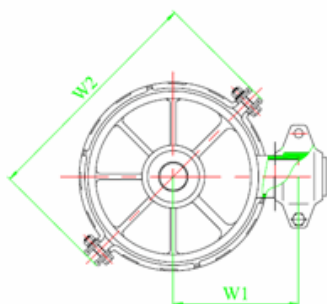

Figure 2



Properties	Length				Diameter	Width	
Units	L	L1	L2	L3	D	W1	W2
SI (mm)	1860	1500	1630	1820	225	180	342
US (inch)	73.2	59.1	64.2	71.7	8.9	7.1	13.5

Operating Parameters

	SI units	US units
Filtrate Flux @ 25°C	40 - 120 l/m ² /hr	24 - 70 gfd
Flow Range	2.0 – 6.1 m ³ /hr	9.2 – 26.7 gpm
pH, Operating	2 - 11	
Temperature	1 - 40°C	34 - 104°F
Max. Inlet Module Pressure	6.0 bar	87 psi
Max. Operating TMP	2.1 bar	30 psi
Max. Backwash Pressure	2.5 bar	36 psi
NaOCl (max)	2,000 mg/L	
TSS (max)	100 mg/L	
Turbidity (max)	300 ntu	
Particle Size (max)	300 μ	
Flow Configuration	Outside In, Dead End Flow	
Expected Filtrate Turbidity	≤ 0.1 NTU	
Expected Filtrate SDI	≤ 2.5	

Important Information

Proper start-up of a UF system is essential to prepare the membranes for operating service and to prevent membrane damage. Following the proper start-up sequence also helps ensure that system operating parameters conform to design specifications so that system water quality and productivity goals can be achieved. Before initiating system start-up procedures, membrane pretreatment, installation of the membrane modules, instrument calibration and other system checks should be completed. Please refer to the product technical manual.

Operation Guidelines

Avoid any abrupt pressure variations during start-up, shutdown, cleaning or other sequences to prevent possible membrane damage. Flush the UF system to remove shipping solution prior to start up. Remove residual air from the system prior to start up. Manually start the equipment. Target a permeate flow of 60% of design during initial operations. Depending on the application, permeate obtained from initial operations should be discarded.

General Information

If operating limits and guidelines given in this bulletin are not strictly followed, the limited warranty will be null and void.

To prevent biological growth during system shutdowns, it is recommended that preservative solution be injected into the membrane modules.

DOW™ Ultrafiltration

Notice: The use of this product in and of itself does not necessarily guarantee the removal of cysts and pathogens from water. Effective cyst and pathogen reduction is dependent on the complete system design and on the operation and maintenance of the system.

Notice: No freedom from any patent owned by Seller or others is to be inferred. Because use conditions and applicable laws may differ from one location to another and may change with time, Customer is responsible for determining whether products and the information in this document are appropriate for Customer's use and for ensuring that Customer's workplace and disposal practices are in compliance with applicable laws and other governmental enactments. Seller assumes no obligation or liability for the information in this document. NO WARRANTIES ARE GIVEN; ALL IMPLIED WARRANTIES OF MERCHANTABILITY OR FITNESS FOR A PARTICULAR PURPOSE ARE EXPRESSLY EXCLUDED.

