

Design Pressure = 1200 PSI @ 120° F
 Min. Design Temperature = 20° F @ 1200 PSI
 Hydrotest Pressure = 1320 PSI

**1200 PSI
 END PORT**

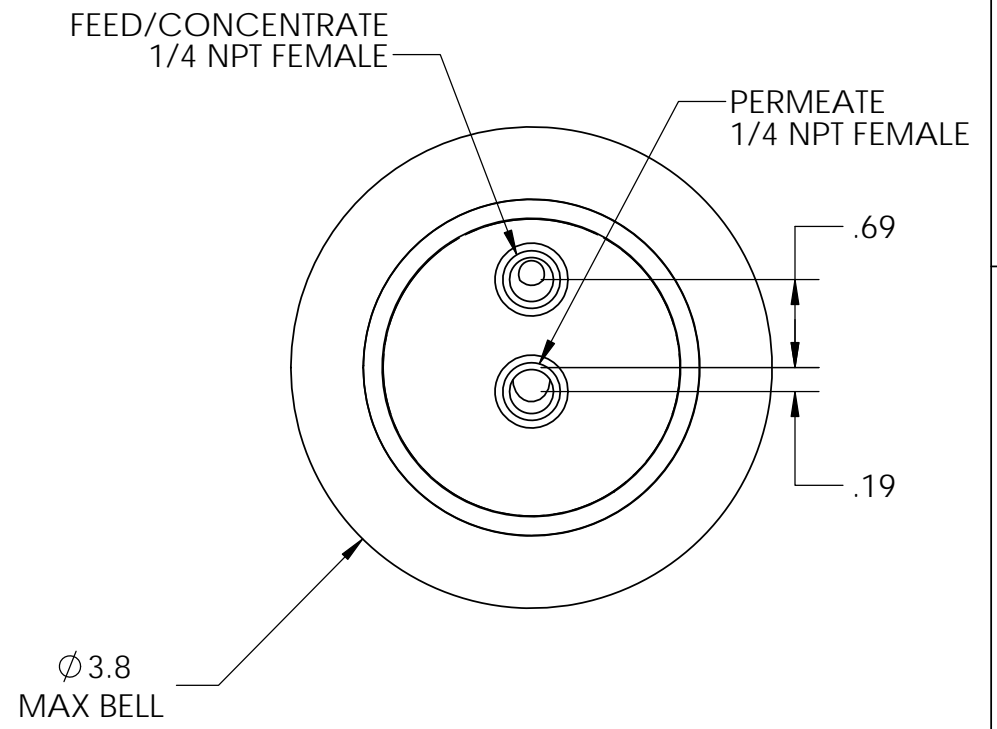
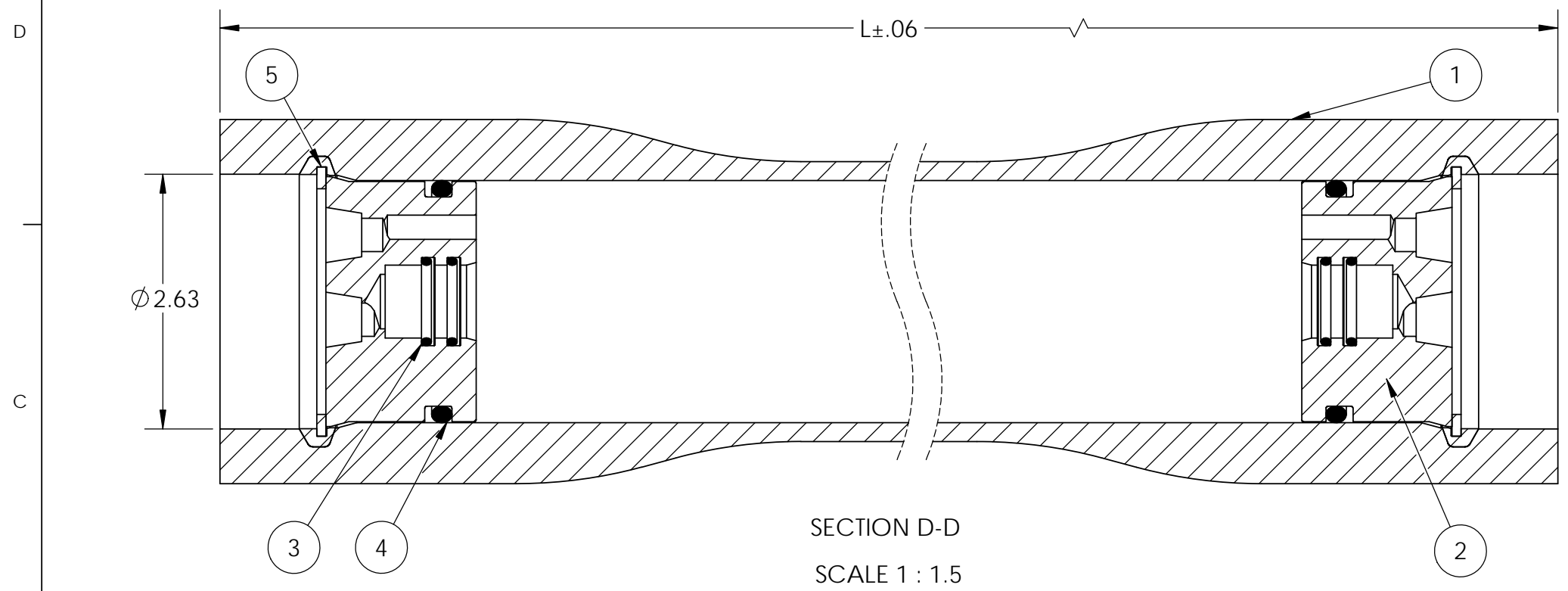

ITEM	QTY	PART NUMBER	DESCRIPTION	MATERIAL
1	1	4020001	Shell	Filament Wound, Epoxy FRP
2	2	4020004	End Plug	Acetal
3	4	6180116-N	PWT Seal	Ethylene Propylene
4	2	6180330-N	Head Seal	Ethylene Propylene
5	2	6144256	Retaining Ring, Head	Stainless Steel, 316

NOTES:
 DIMENSIONS IN INCHES (MM APPROX.)
 FOR REFERENCE ONLY, NOT FOR CONSTRUCTION UNLESS CERTIFIED
 INCORRECT MANIFOLDING WILL CAUSE SEVERE LOCAL STRESS AROUND PORT AND MAY RESULT IN LEAKS AND PREMATURE FAILURE. TAKE EVERY PRECAUTION LISTED IN THE ENGINEERING PACKET OR USERS MANUAL
 INTERNAL PERMEATE PRESSURE MUST NOT EXCEED 125 PSI
 SPECIFICATIONS SUBJECT TO CHANGE WITHOUT NOTICE

Shell Length Code	L inch	Empty Weight lb
-14"	18	TBD
-21"	25	TBD
-1	44	TBD
-2	84	TBD

Distributed By:
APPLIED MEMBRANES INC.

APPROVED D.G. 8/5/15				
CHECKED R.R. 8/5/15	PRO 2.5-1200-EP			
DRAWN D.G. 8/5/15	ECO N/A	REVISED N/A	DRAWING 1020001	REV A