

**600 PSI  
END PORT**

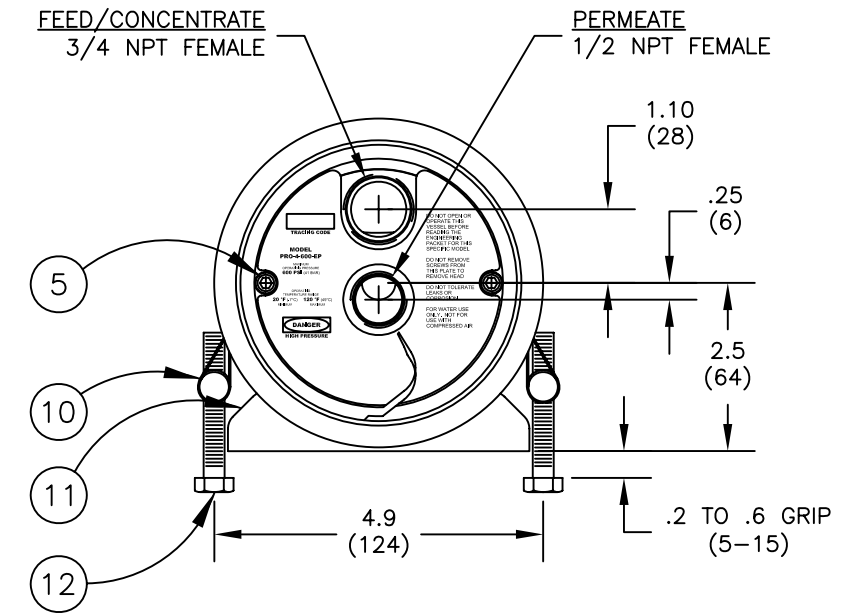
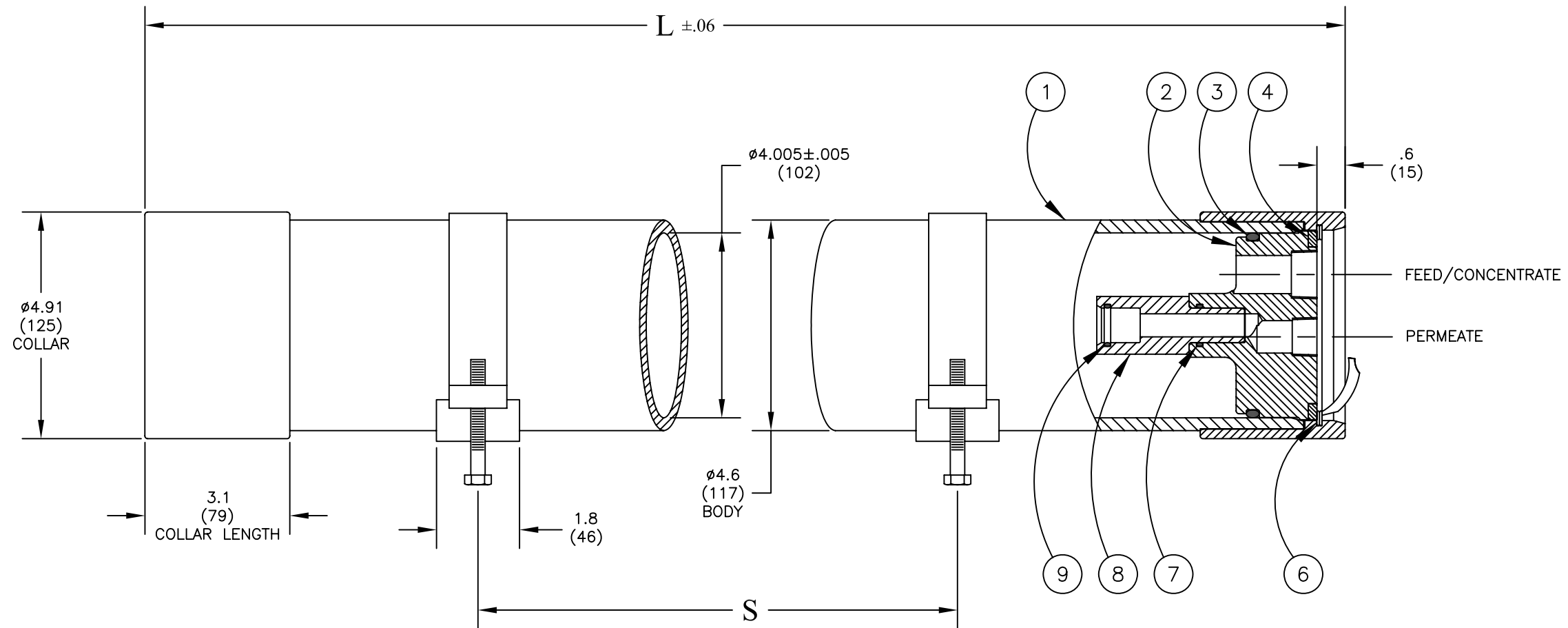

Shell Length Code	L inch (mm)	S Span in (mm)	Empty Weight lb (kg)
-1	49.1 (1247)	28 (711)	15 (7)
-2	89.1 (2263)	51 (1295)	25 (11)
-3	129.1 (3279)	73 (1854)	35 (16)
-4	169.1 (4295)	2 @ 64 (1626)	45 (20)
-5	209.1 (5311)	2 @ 78 (1981)	55 (25)
-6	249.1 (6327)	2 @ 92 (2337)	65 (30)

ITEM	QTY	P/N	DESCRIPTION	MATERIAL
1	1	3040007	Shell	Filament Wound, Epoxy FRP
2	2	4040054-1	End Plug	PVC Thermoplastic
3	2	6180342	Head Seal	Ethylene Propylene
4	2	4040060-1	Bearing Ring	Stainless Steel, 300 Series
5	4	6150002	Screw, Bearing Ring	Stainless Steel, 300 Series
6	2	4040079	Retaining Ring w/ Finger Pull	Stainless Steel, 316 Series
7	2	6180116	Adapter Seal	Ethylene Propylene
8	2	A/R	Adapter	PVC Thermoplastic
9	2	A/R	PWT Seal	Ethylene Propylene
10	2	4040040	Strap Assembly	Stainless Steel, 300 Series
11	2	4040037	Support Saddle	Polyurethane
12	4	6150001	Strap Screw	Stainless Steel, 300 Series

**NOTES:**

DIMENSIONS IN INCHES (MM APPROX.)

FOR REFERENCE ONLY, NOT TO BE USED FOR CONSTRUCTION UNLESS CERTIFIED

INCORRECT MANIFOLDING WILL CAUSE SEVERE LOCAL STRESS AROUND PORT AND MAY RESULT IN LEAKS AND PREMATURE FAILURE. TAKE EVERY PRECAUTION LISTED IN THIS PACKET.

INTERNAL PERMEATE PRESSURE MUST NOT EXCEED 125 PSI.

SPECIFICATIONS SUBJECT TO CHANGE WITHOUT NOTICE



www.protec-arisawa.com

**PRO 4-600-EP**

ENGR  
AP  
1/27/04  
QLTY  
WJ  
1/27/04  
MRKT  
DWE  
1/27/04

ECO	REVISED	DRAWING	REV
10119	4/28/11	104005	D