

Design Pressure = 300 PSI @ 120 °F
 Min. Design Temperature = 20 °F @ 300 PSI
 Hydrotest Pressure = 330 PSI

300 PSI
 END PORT

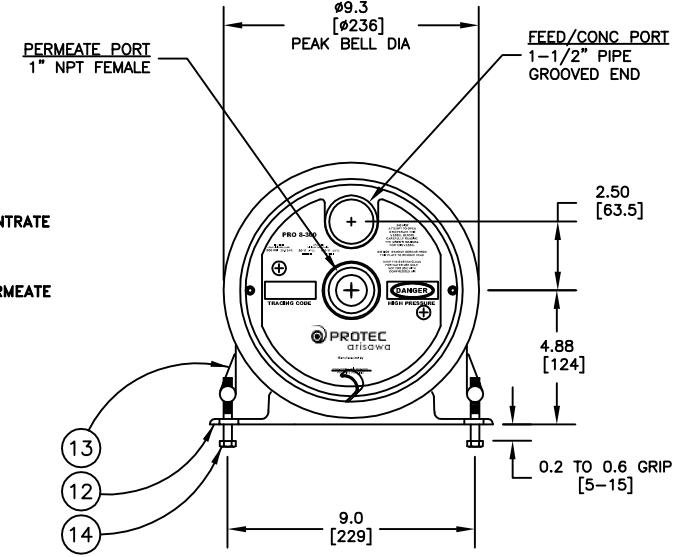
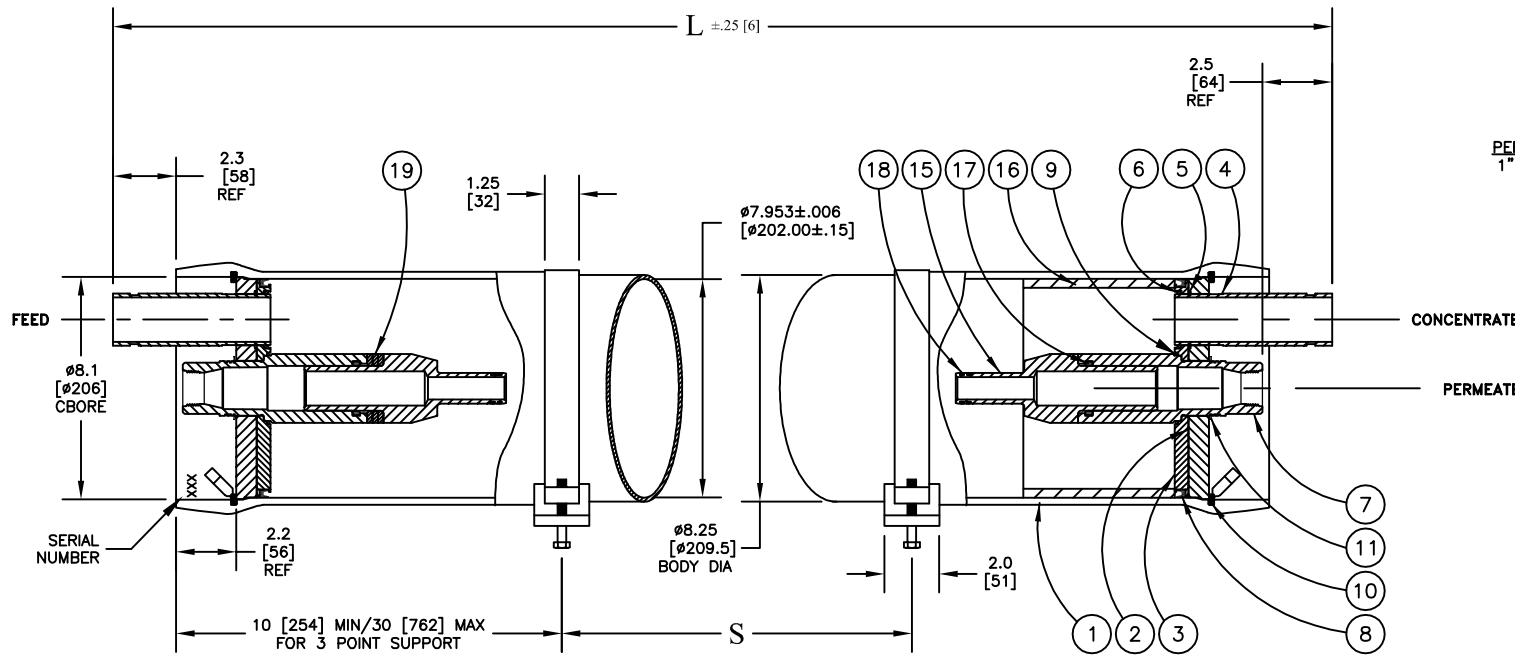

NOTE: STANDARD PARTS ARE SHOWN FOR REFERENCE ONLY
 CHECK ORIGINAL ORDER FOR ORDERING SPARE PARTS

ITEM	QTY	P/N	DESCRIPTION	MATERIAL
1	1	4080002	Shell	Filament Wound, Epoxy FRP
2	2	4080027	Bearing Plate	6061-T6 Aluminum, SB-221
3	2	4080065-1	Sealing Plate	PVC Thermoplastic
4	2	4080011-1	Feed/Concentrate Port	Stainless Steel, 316, SA-312
5	2	6121187	Retaining Ring, F/C Port	Stainless Steel, 316
6	2	6184604-N	O-Ring Seal, F/C Port	Ethylene Propylene
7	2	4080289	Permeate Port	Noryl GFN2
8	2	6100442MK	Head Seal	Ethylene Propylene
9	2	6180229-N	Permeate Port Seal	Ethylene Propylene
10	2	4080320	Retaining Ring w/ Finger Pull	Stainless Steel, 316
11	2	6121200	Retaining Ring, Permeate Port	Stainless Steel, 316
12	2*	4080173	Support Saddle	Thermoplastic Rubber
13	2	4080137	Strap Assembly	Stainless Steel, 316
14	4	6150001	Strap Screw	Stainless Steel, 316
15	2	A/R	Adapter	PVC Thermoplastic
16	1	4080109-1	Thrust Ring	PVC Thermoplastic
17	2	6180326-N	Adapter Seal	Ethylene Propylene
18	A/R	A/R	PWT Seal	Ethylene Propylene
19	3	4080062-4	Shim, Adapter	Noryl GFN2

*3 each with shell length -7 and longer

Shell Length Code	L inch (mm)	S Span in (mm)	Empty Weight lb (kg)
-1	63 [1599]	34 [864]	42 (19)
-1.5	83 [2107]	45 [1143]	48 (22)
-2	103 [2615]	56 [1422]	53 (24)
-3	143 [3631]	80 [2032]	66 (30)
-4	183 [4647]	104 [2642]	77 (35)
-5	223 [5663]	128 [3251]	88 (40)
-6	263 [6679]	150 [3810]	99 (45)
-7	303 [7696]	3 PTS.	110 (50)
-7.5	323 [8203]	3 PTS.	117 (53)
-8	343 [8712]	3 PTS.	121 (55)

NOTES:
 DIMENSIONS IN INCHES (MM APPROX.)
 FOR REFERENCE ONLY, NOT FOR CONSTRUCTION UNLESS CERTIFIED
 SHIMMING OF THE SADDLES MAY BE REQUIRED
 CENTER VESSEL ON 2 OR 3 SUPPORTS AT SPAN(S) "S".
 INCORRECT MANIFOLDING WILL CAUSE SEVERE LOCAL STRESS AROUND PORT AND MAY RESULT IN LEAKS AND PREMATURE FAILURE. TAKE EVERY PRECAUTION LISTED IN THE ENGINEERING PACKET OR USERS MANUAL.
 INTERNAL PERMEATE PRESSURE MUST NOT EXCEED 125 PSI.
 ASME SECTION X, 2010
 RP CODE STAMP OPTIONAL
 SPECIFICATIONS SUBJECT TO CHANGE WITHOUT NOTICE



PRO 8-300-EP

APPROVED
 LS
 7/05/12
 CHECKED
 -
 DRAWN
 BOA
 7/05/12

ECO	REVISED	DRAWING	REV
12056	7/05/12	101008	Q