

# Membrane Housing Pressure Vessels for 2.5" Diameter Seawater RO Membranes

**1000  
PSI**

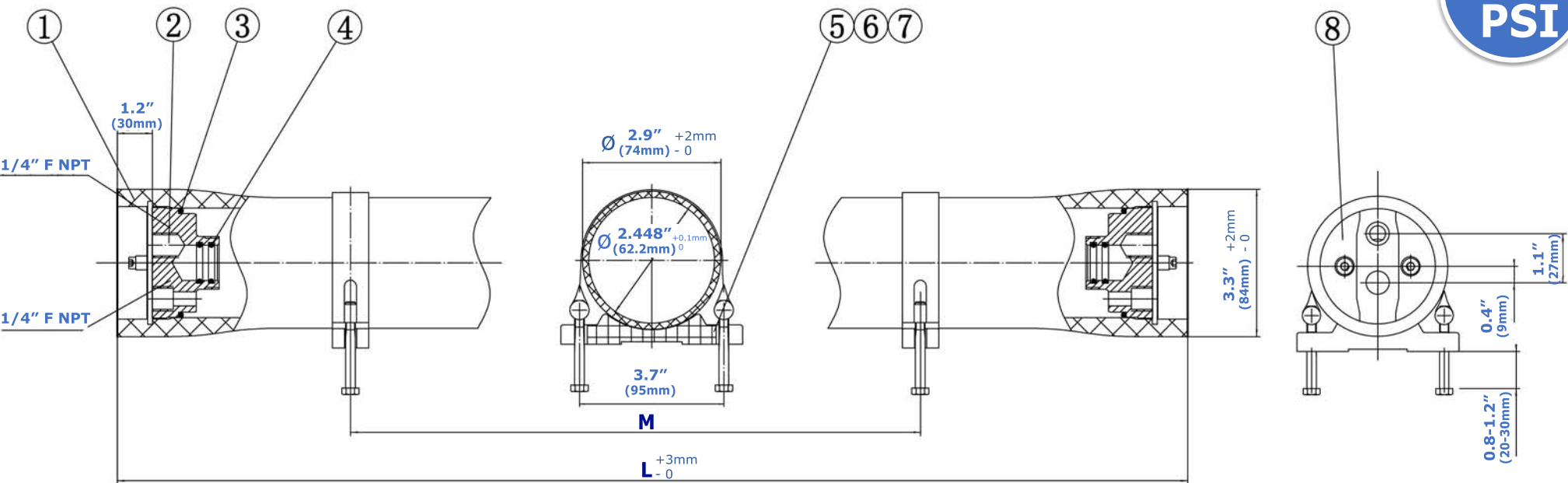

Assembly Part#	Length (L)	Mounting Location (M)	Approximate Weight
PV2514A1000E	17.5" (445 mm)	7.9" (200 mm)	9lb (4 kg)
PV2521A1000E	24.5" (623 mm)	15.7" (400 mm)	9lb (4 kg)
PV2540A1000E	43.5" (1106 mm)	27.6" (700 mm)	13lb (6 kg)

Ref. #	Description	Material	Qty. Incl.
①	Vessel Shell	Epoxy FRP	1
②	End Plug	2507SST	2
③	Outer O-Ring	EPDM	2
④	Inner O-Ring	EPDM	4
⑤	Mounting Saddle	Rubber	2
⑥	Mounting Strap	316SST & Rubber	2
⑦	Strap Screw	316LSST	4
⑧	Locking Crescents	316LSST	4

**Design Notes**

1. Design Pressure: 1000 psi (69 bar)
2. Minimum Operating Temperature: 14°F (-10°C)
3. Maximum Operating Temperature: 120°F (49°C)
4. Factory Test Pressure: 1.5 x Design Pressure
5. Working Medium: Water, pH 3-11 (Cleaning <30 mins: pH 2-12)
6. Please operate in accordance with User Guide.
7. Flexible piping should be used on permeate connection to manifold.
8. Subject to change without prior notice.

